

# Structural Calculations

For

**19-07 Romine**  
Valley County, Idaho

Prepared by



2019-07873  
July 10, 2019

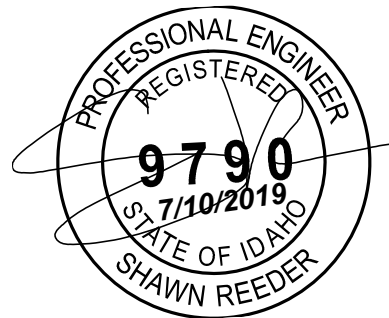



# Design Criteria

Project Name: 19-07 Romine  
 Job Number: 2019-07873  
 Location: Valley County, Idaho

Engineer: **SB**  
 Checker: **KJ**

Governing Code: 2015 IBC

### Snow Criteria

Roof Load ( $P_f$ )	150 psf	
Ground Load ( $P_g$ )	150 psf	
Exposure Factor ( $C_e$ )	1.0	Partially
Thermal Factor ( $C_t$ )	1.0	Typical
Slope Factor ( $C_s$ )	100.0%	
Importance ( $I_s$ )	1.0	

### Wind Criteria

Wind Speed ( $V_3$ )	115 mph	
Wind Exposure	B	Urban / wooded
Wind Importance ( $I_w$ )	1.0	
Building Category	II	

### Seismic Criteria

Site Class	D	Stiff Soil
$S_s$	0.51	$F_a$ 1.39
$S_1$	0.15	$F_v$ 2.19
$S_{D5}$	0.47	$S_{D1}$ 0.22
Risk Category	II	Other
Seismic Importance ( $I_E$ )	1.0	
Seismic Design Category (SDC)	D	

Wall Material	Design Base Shear	Seismic Response Coefficient, R	
OSB	.07Wp	6.5	Typ @ Ext
GYP	.24Wp	2	Typ @ Int

### Live Loads

Typ Residential	40 psf
	-
	-

### Soil Bearing

Typical 1500 psf

### Roof Dead Loads:

Deck	1.5
Insulation	2.0
Roofing	3.0
Joist	2.5
Ceiling	3.0
Misc	4.5
<b>TOTAL</b>	<b>17 psf</b>

### Floor Dead Loads:

Deck	18.0
Joist	2.0
Ceiling	0.0
Flooring	1.0
Misc	5.0
<b>TOTAL</b>	<b>26 psf</b>

### Exterior Wall Dead Loads:

Studs	2.0
Siding	2.5
Insulation	0.5
Gyp. Board	2.5
Sheathing	1.5
Misc	3.0
<b>TOTAL</b>	<b>12 psf</b>

### Interior Wall Dead Loads:

Studs	2.0
Gyp. Board	2.5
-	-
-	-
-	-
Misc	3.0
<b>TOTAL</b>	<b>8 psf</b>



Project # : 2019-07873  
Project: 19-07 Romine

## OSB Seismic Loading Analysis

$$S_s = 0.507$$

$$C_T = 0.020$$

$$S_1 = 0.152$$

$$h_n = 29.50 \text{ ft}$$

$$F_a = 1.4$$

$$F_v = 2.2$$

$$R = 6.5$$

$$I_E = 1.0$$

$$S_{MS} = F_a S_s = 0.7068$$

$$S_{M1} = F_v S_1 = 0.3332$$

$$S_{DS} = 2/3 S_{MS} = 0.4712$$

$$S_{D1} = 2/3 S_{M1} = 0.2221$$

Seismic Design Category

C

D

$$C_s = 1.2 S_{DS} / (R I_E) = 0.0725$$

**Controls**

$$T_a = C_T h_n^{3/4} = 0.2532$$

$$C_s < S_{D1} / [(R I_E) T] = 0.1350$$

$$C_s > 0.044 S_{DS} I_E = 0.0207$$

$$C_s > 0.5 S_1 / (R I_E) = 0.0117$$

$$V = C_s W = \mathbf{0.0725 \text{ W}}$$

$$0.7 V = \mathbf{0.0507 \text{ W}}$$



Project # : 2019-07873  
 Project: 19-07 Romine

## OSB Seismic Component Loading

$$w_p = 1 \text{ psf} \quad \text{weight of element}$$

$$V_{px} = 0 \text{ plf} \quad \text{Portion of seismic shear load at the level of the diaphragm, required to be transferred to the components of the vertical seismic-force-resisting system because of the offsets or changes in the stiffness of the vertical components above of below the diaphragm.}$$

$$w_w = 1 \text{ psf} \quad \text{weight of wall}$$

$$L_b = 52 \text{ ft} \quad \text{length of the building}$$

NOTE: Use 1 for unit weight to achieve an answer per element unit weight

### Connections

$$F_p = 0.133 S_{DS} w_p = \mathbf{0.06} \text{ psf}$$

or

$$F_p = 0.05 w_p = \mathbf{0.05} \text{ psf}$$

### Diaphragm

$$F_p = 0.2 I_E S_{DS} w_p + V_{px} = \mathbf{0.09} \text{ psf}$$

$$F_{p,max} = 0.4 I_E S_{DS} w_p + V_{px} = \mathbf{0.19} \text{ psf}$$

### Bearing Walls & Shear Walls

#### Out of Plane Forces

$$F_p = 0.40 I_E S_{DS} w_w = \mathbf{0.19} \text{ psf} \quad \text{Controls} \quad 12.11.1$$

$$F_p = 0.10 w_w = \mathbf{0.10} \text{ psf} \quad 12.11.1$$

### Anchorage

$$F_p = 0.40 I_E S_{DS} w_w k_a = \mathbf{0.3} \text{ psf} \quad 12.11-1$$

$$F_p = 0.2 I_E k_a w_w = \mathbf{0.3040} \text{ psf} \quad \text{Controls}$$

$$k_a = 1.0 + L_b / 100 = \mathbf{1.5200} \quad 12.11-2$$

Note: 12.11.2.2.2 The strength design forces for steel elements of the structural wall anchorage system, with exception of anchor bolts and reinforcing steel, shall be increased by 1.4 times the forces otherwise noted above.

## WIND LOADING ANALYSIS - Main Wind-Force Resisting System

**Per ASCE 7-10 Code for Enclosed or Partially Enclosed Buildings  
Using Method 2: Analytical Procedure (Section 27 & 28) for Low-Rise Buildings**

Job Name:	19-07 Romine	Location:	Valley County, Idaho
Job Number:	2019-07873	Engineer:	SB      Checker: KJ

**Input Data:**

Wind Speed, V =	115	mph (Wind Map, Figure 26.5-1A-C)
Bldg. Classification =	II	(Table 1.5-1 Risk Category)
Exposure Category =	B	(Sect. 26.7)
Ridge Height, hr =	29.50	ft. (hr >= he)
Eave Height, he =	19.50	ft. (he <= hr)
Building Width =	48.00	ft. (Normal to Building Ridge)
Building Length =	52.00	ft. (Parallel to Building Ridge)
Roof Type =	Gable	(Gable or Monoslope)
Topo. Factor, Kzt =	1.00	(Sect. 26.8 & Figure 26.8-1)
Direct. Factor, Kd =	0.85	(Table 26.6)
Enclosed? (Y/N)	Y	(Sect. 26.2 & Table 26.11-1)
Hurricane Region?	N	

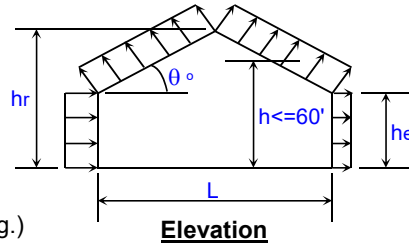
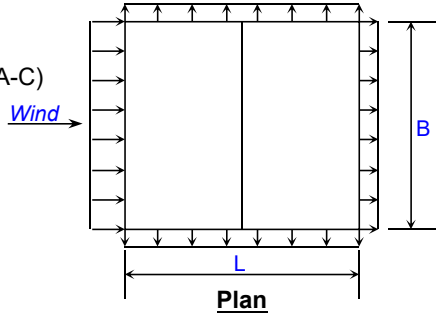

**Resulting Parameters and Coefficients:**

Roof Angle, $\theta$ =	22.62	deg.
Mean Roof Ht., h =	24.50	ft. (h = (hr+he)/2, for angle >10 deg.)

Check Criteria for a Low-Rise Building:

1. Is h <= 60' ? Yes, O.K.      2. Is h <= Lesser of L or B? Yes, O.K.

External Pressure Coeffs., GCpf (Fig. 28.4-1):

(For values, see following wind load tabulations.)

Positive & Negative Internal Pressure Coefficients, GCpi (Table 26.11-1):

+GCpi Coef. =	0.18	(positive internal pressure)
-GCpi Coef. =	-0.18	(negative internal pressure)

If h < 15 then:  $K_h = 2.01 \cdot (15/z_g)^{(2/\alpha)}$  (Table 28.3-1)

If h >= 15 then:  $K_h = 2.01 \cdot (z/z_g)^{(2/\alpha)}$  (Table 28.3-1)

(Note: z not < 30' for Exp. B)

$\alpha$ =	7.00	(Table 26.9-1)
$z_g$ =	1200	(Table 26.9-1)
$K_h$ =	0.70	( $K_h = K_z$ evaluated at z = h)

Velocity Pressure:  $q_z = 0.00256 \cdot K_z \cdot K_{zt} \cdot K_d \cdot V^2$  (Sect. 28.3.2, Eq. 28.3-1)

$q_h = 20.16$  psf       $q_h = 0.00256 \cdot K_h \cdot K_{zt} \cdot K_d \cdot V^2$  ( $q_z$  evaluated at z = h)

Design Net External Wind Pressures (Sect. 28.4.1):

$p = q_h \cdot [(GCpf) - (+/-GCpi)]$  (psf, Eq. 28.4-1)

Wall and Roof End Zone Widths 'a' and '2\*a' (Fig. 28.4-1):

a =	4.80	ft.
2*a =	9.60	ft.



**Low-Rise  
Buildings  
h ≤ 60'**

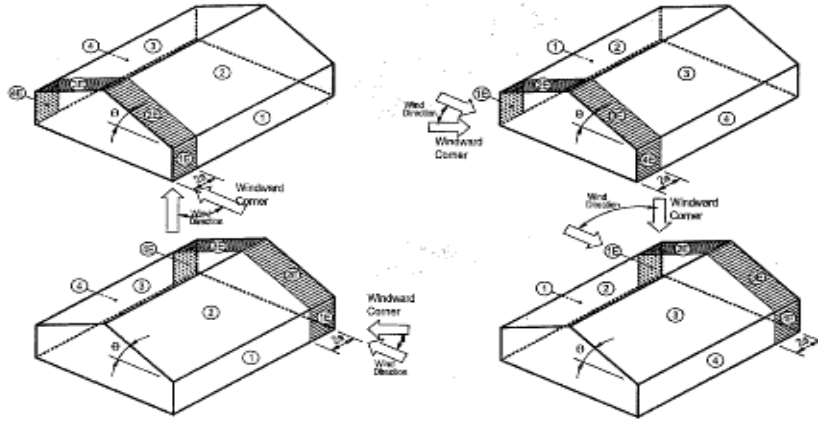

**Load Case A**

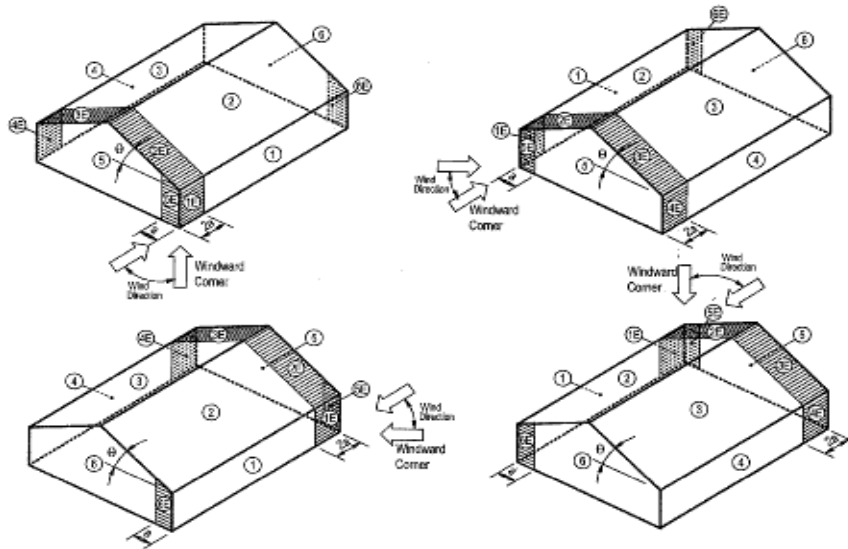

**Load Case B**

**Basic Load Cases**

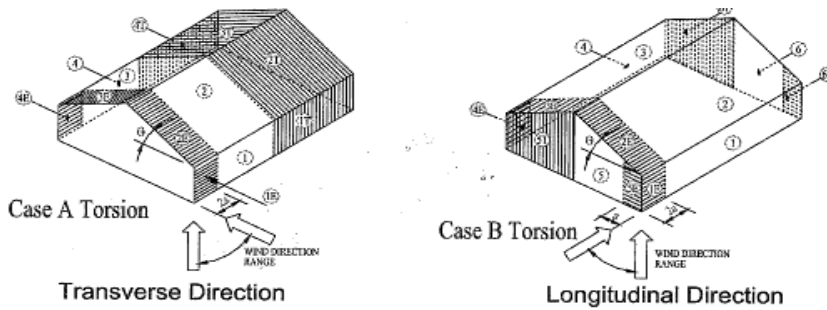

**Torsional Load Cases**

## WIND LOADING ANALYSIS - Wall Components and Cladding

**Per ASCE 7-10 Code for Buildings of Any Height  
Using Part 1 & 3: Analytical Procedure (Section 30.4 & 30.6)**

Job Name:	19-07 Romine	Location:	Valley County, Idaho
Job Number:	2019-07873	Engineer:	SB      Checker: KJ

### Input Data:

Wind Speed, V =	115	mph (Wind Map, Figure 26.5-1A-C)
Bldg. Classification =	II	(Table 1.5-1 Risk Category)
Exposure Category =	B	(Sect. 26.7)
Ridge Height, hr =	29.5	ft. (hr >= he)
Eave Height, he =	19.5	ft. (he <= hr)
Building Width =	48	ft. (Normal to Building Ridge)
Building Length =	52	ft. (Parallel to Building Ridge)
Roof Type =	Gable	(Gable or Monoslope)
Topo. Factor, Kzt =	1	(Sect. 26.8 & Figure 26.8-1)
Direct. Factor, Kd =	0.85	(Table 26.6)
Enclosed? (Y/N)	Y	(Sect. 28.6-1 & Figure 26.11-1)
Hurricane Region?	N	
Component Name =	Wall	(Girt, Siding, Wall, or Fastener)
Effective Area, Ae =	27	ft.^2 (Area Tributary to C&C)

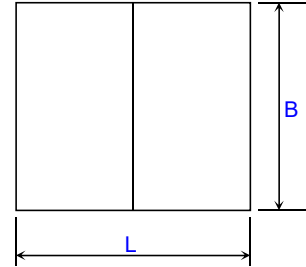

**Plan**

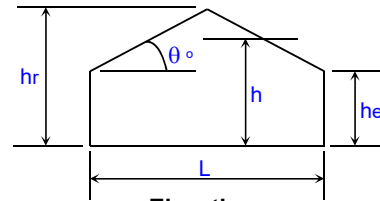

**Elevation**

### Resulting Parameters and Coefficients:

Roof Angle, θ =	22.62	deg.
Mean Roof Ht., h =	24.50	ft. (h = (hr+he)/2, for roof angle >10 deg.)

#### Wall External Pressure Coefficients, GCp:

GCp Zone 4 Pos. =	0.92	(Fig. 30.4-1)
GCp Zone 5 Pos. =	0.92	(Fig. 30.4-1)
GCp Zone 4 Neg. =	-1.02	(Fig. 30.4-1)
GCp Zone 5 Neg. =	-1.25	(Fig. 30.4-1)

#### Positive & Negative Internal Pressure Coefficients, GCpi (Figure 26.11-1):

+GCpi Coef. =	0.18	(positive internal pressure)
-GCpi Coef. =	-0.18	(negative internal pressure)

If  $z \leq 15$  then:  $K_z = 2.01 \cdot (15/zg)^{(2/\alpha)}$ , If  $z > 15$  then:  $K_z = 2.01 \cdot (z/zg)^{(2/\alpha)}$  (Table 30.3-1)

$\alpha =$	7.00	(Table 26.9-1)      (Note: z not < 30' for Exp. B, Case 1)
$z_g =$	1200	(Table 26.9-1)
$K_h =$	0.70	( $K_h = K_z$ evaluated at $z = h$ )

Velocity Pressure:  $q_z = 0.00256 \cdot K_z \cdot K_{zt} \cdot K_d \cdot V^2$  (Sect. 30.3.2, Eq. 30.3-1)

$q_h =$	20.16	psf $q_h = 0.00256 \cdot K_h \cdot K_{zt} \cdot K_d \cdot V^2$ ( $q_z$ evaluated at $z = h$ )
---------	-------	---

#### Design Net External Wind Pressures (Sect. 30.4 & 30.6):

For  $h \leq 60$  ft.:  $p = q_h \cdot ((GCp) - (+/-GCpi))$  (psf)

For  $h > 60$  ft.:  $p = q \cdot (GCp) - q_i \cdot (+/-GCpi)$  (psf)

where:  $q = q_z$  for windward walls,  $q = q_h$  for leeward walls and side walls

$q_i = q_h$  for all walls (conservatively assumed per Sect. 30.6)



**Wall Components and Cladding:**

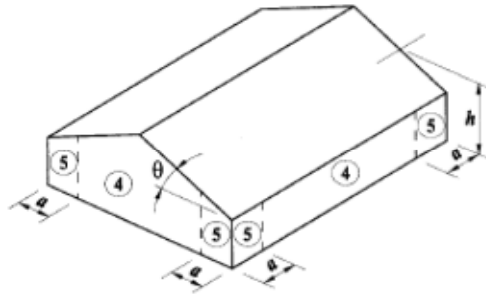

**Wall Zones for Buildings with  $h \leq 60$  ft.**

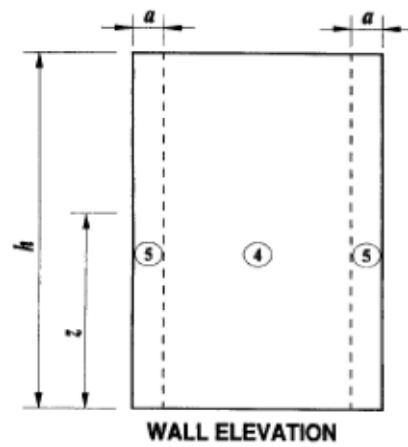

**Wall Zones for Buildings with  $h > 60$  ft.**

## WIND LOADING ANALYSIS - Roof Components and Cladding

Per ASCE 7-10 Code for Bldgs. of Any Height with Gable Roof  $\theta \leq 45^\circ$  or Monoslope Roof  $\theta \leq 3^\circ$   
Using Part 1 & 3: Analytical Procedure (Section 30.4 & 30.6)

Job Name:	19-07 Romine	Location:	Valley County, Idaho
Job Number:	2019-07873	Engineer:	SB      Checker: KJ

### Input Data:

Wind Speed, V =	115	mph (Wind Map, Figure 26.5-1A-C)
Bldg. Classification =	II	(Table 1-1 Occupancy Category)
Exposure Category =	B	(Sect. 26.7)
Ridge Height, hr =	29.5	ft. (hr $\geq$ he)
Eave Height, he =	19.5	ft. (he $\leq$ hr)
Building Width =	48	ft. (Normal to Building Ridge)
Building Length =	52	ft. (Parallel to Building Ridge)
Roof Type =	Gable	(Gable or Monoslope)
Topo. Factor, Kzt =	1	(Sect. 26.8 & Figure 26.8-1)
Direct. Factor, Kd =	0.85	(Table 26.6)
Enclosed? (Y/N)	Y	(Sect. 28.6-1 & Figure 26.11-1)
Hurricane Region?	N	
Component Name =	Joist	(Purlin, Joist, Decking, or Fastener)
Effective Area, Ae =	768	ft. <sup>2</sup> (Area Tributary to C&C)
Overhangs? (Y/N)	Y	(if used, overhangs on all sides)

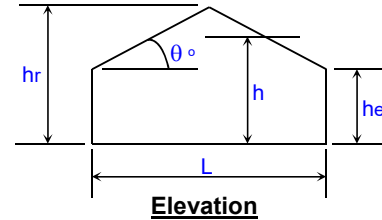
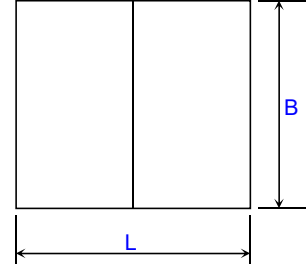

### Resulting Parameters and Coefficients:

Roof Angle, $\theta$ =	22.62	deg.
Mean Roof Ht., h =	24.50	ft. (h = (hr+he)/2, for roof angle >10 deg.)

### Roof External Pressure Coefficients, GCp:

GCp Zone 1-3 Pos. =	0.30	(Fig. 30.4-2A, 30.4-2B, and 30.4-2C)
GCp Zone 1 Neg. =	-0.80	(Fig. 30.4-2A, 30.4-2B, and 30.4-2C)
GCp Zone 2 Neg. =	-2.20	(Fig. 30.4-2A, 30.4-2B, and 30.4-2C)
GCp Zone 3 Neg. =	-2.50	(Fig. 30.4-2A, 30.4-2B, and 30.4-2C)

### Positive & Negative Internal Pressure Coefficients, GCpi (Figure 26.11-1):

+GCpi Coef. =	0.18	(positive internal pressure)
-GCpi Coef. =	-0.18	(negative internal pressure)

If  $z \leq 15$  then:  $K_z = 2.01 \cdot (15/zg)^{(2/\alpha)}$ , If  $z > 15$  then:  $K_z = 2.01 \cdot (z/zg)^{(2/\alpha)}$  (Table 30.3-1)

$\alpha$ =	7.00	(Table 26.9-1)
zg =	1200	(Table 26.9-1)
Kh =	0.70	(Kh = Kz evaluated at z = h)

(Note: z not < 30, Exp. B, Case 1)

Velocity Pressure:  $q_z = 0.00256 \cdot K_z \cdot K_{zt} \cdot K_d \cdot V^2$  (Sect. 30.3.2, Eq. 30.3-1)

qh =	20.16	psf	qh = $0.00256 \cdot K_h \cdot K_{zt} \cdot K_d \cdot V^2$ (qz evaluated at z = h)
------	-------	-----	---

### Design Net External Wind Pressures (Sect. 30.4 & 30.6):

For  $h \leq 60$  ft.:  $p = q_h \cdot ((GCp) - (+/-GCpi))$  (psf)

For  $h > 60$  ft.:  $p = q \cdot (GCp) - q_i \cdot (+/-GCpi)$  (psf)

where:  $q = q_h$  for roof

$q_i = q_h$  for roof (conservatively assumed per Sect. 30.6)

Wind Load Tabulation for Roof Components & Cladding							
Component	z (ft.)	Kh	qh (psf)	p = Net Design Pressures (psf)			
				Zone 1,2,3 (+)	Zone 1 (-)	Zone 2 (-)	Zone 3 (-)
Joist	0	0.70	20.16	9.68	-19.76	-47.98	-54.03
	15.00	0.70	20.16	9.68	-19.76	-47.98	-54.03
	20.00	0.70	20.16	9.68	-19.76	-47.98	-54.03
	25.00	0.70	20.16	9.68	-19.76	-47.98	-54.03
	For z = hr:	29.50	0.70	20.16	9.68	-19.76	-47.98
For z = he:	19.50	0.70	20.16	9.68	-19.76	-47.98	-54.03
For z = h:	24.50	0.70	20.16	9.68	-19.76	-47.98	-54.03

- Notes: 1. (+) and (-) signs signify wind pressures acting toward & away from respective surfaces.
2. Width of Zone 2 (edge), 'a' = 4.80 ft.
3. Width of Zone 3 (corner), 'a' = 4.80 ft.
4. For monoslope roofs with  $\theta \leq 3$  degrees, use Fig. 30.4-2A for 'GCp' values with 'qh'.
5. For buildings with  $h > 60'$  and  $\theta > 10$  degrees, use Fig. 30.6-1 for 'GCpi' values with 'qh'.
6. For all buildings with overhangs, use Fig. 30.4-2B for 'GCp' values per Sect. 30.10.
7. If a parapet  $\geq 3'$  in height is provided around perimeter of roof with  $\theta \leq 10$  degrees, Zone 3 shall be treated as Zone 2.
8. Per Code Section 30.2.2, the minimum wind load for C&C shall not be less than 16 psf.
9. References : a. ASCE 7-02, "Minimum Design Loads for Buildings and Other Structures".  
b. "Guide to the Use of the Wind Load Provisions of ASCE 7-02"  
by: Kishor C. Mehta and James M. Delahay (2004).

**Roof Components and Cladding:**

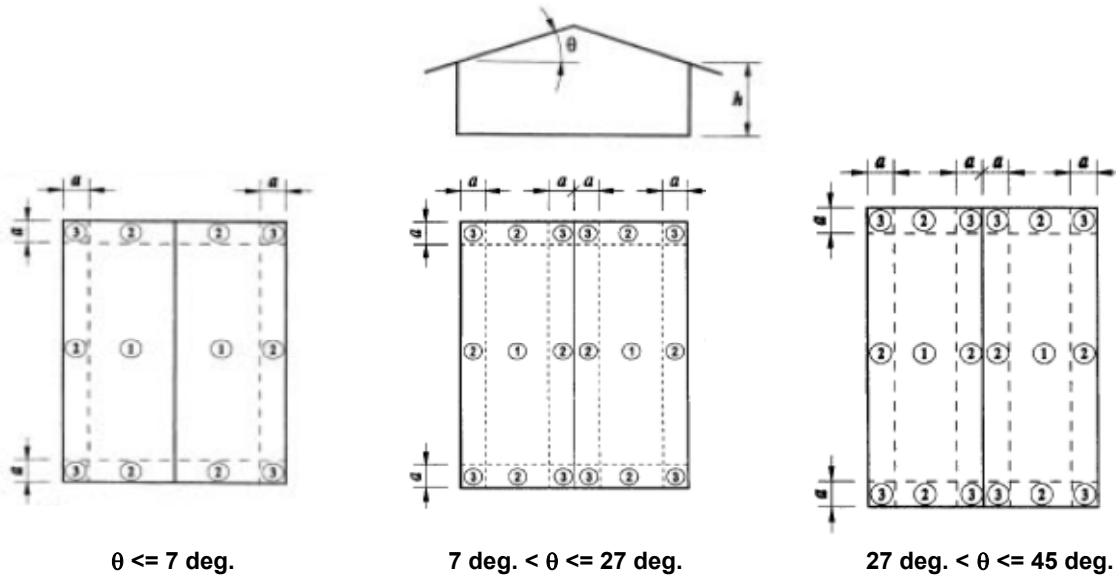

**Roof Zones for Buildings with  $h \leq 60 \text{ ft.}$**   
 (for Gable Roofs  $\leq 45^\circ$  and Monoslope Roofs  $\leq 3^\circ$ )

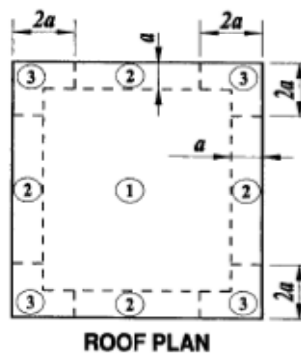

**Roof Zones for Buildings with  $h > 60 \text{ ft.}$**   
 (for Gable Roofs  $\leq 10^\circ$  and Monoslope Roofs  $\leq 3^\circ$ )



Project: 19-07 Romine  
 Project #: 2019-07873  
 Location: Valley County, Idaho  
 Engineer: SB  
 Checker: KJ

## Wind Shear Force Calculations

From 'ASCE 7-10 Wind Loading Analysis':

LOAD CASE 'A'	
a = 4.80 feet	2a = 9.60 feet
Z1 = 7.21 psf	Z1E = 11.92 psf
Z2 = -12.79 psf	Z2E = -18.12 psf
Z3 = -13.04 psf	Z3E = -16.70 psf
Z4 = -11.98 psf	Z4E = -15.69 psf

LOAD CASE 'B'	
a = 4.80 psf	2a = 9.60 feet
Z1 = 4.44 psf	Z1E = 8.67 psf
Z2 = -17.54 psf	Z2E = -25.20 psf
Z3 = -11.09 psf	Z3E = -14.31 psf
Z4 = -9.48 psf	Z4E = -12.30 psf

'A' FACTORED LOADS	
$0.6*W_r = (Z_2 + Z_3) * 0.6 =$	<b>0.2 psf</b>
$0.6*W_{rE} = (Z_{2E} + Z_{3E}) * 0.6 =$	<b>0.9 psf</b>
$0.6*W_w = (Z_1 + Z_4) * 0.6 =$	<b>11.5 psf</b>
$0.6*W_{wE} = (Z_{1E} + Z_{4E}) * 0.6 =$	<b>16.6 psf</b>

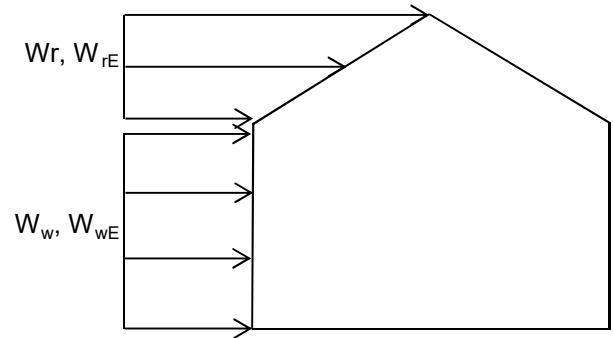

'B' FACTORED LOADS	
$0.6*W_r = (Z_2 + Z_3) * 0.6 =$	<b>3.9 psf</b>
$0.6*W_{rE} = (Z_{2E} + Z_{3E}) * 0.6 =$	<b>6.5 psf</b>
$0.6*W_w = (Z_1 + Z_4) * 0.6 =$	<b>8.3 psf</b>
$0.6*W_{wE} = (Z_{1E} + Z_{4E}) * 0.6 =$	<b>12.6 psf</b>

Wall Line	Wind Force (psf)	Wall ht (ft)	Upr. Flr Wall ht (ft)	wall line dist. (ft)	+	Wind Force (psf)	wall ht (ft)	Wr, We truss (ft)	wall line dist (ft)	+	Shear, Upper (#)	=	Wind Force (kips)
X1-2	13.23	10	0	28.30	+	9.60		10.00	28.3	+		=	2.29
X2-2	13.23	10	0	28.30	+	9.60		10.00	28.3	+		=	2.29
Y1-2	12.45	5.5	0	52.00	+	9.60		10.00	52	+		=	3.39
Y2-2	12.45	5.5	0	52.00	+	9.60		10.00	52	+		=	3.39
X1-1	14.25	16	0	17.70	+	9.60		3.00	17.7	+		=	1.26
X2-1	12.57	9	0	46.00	+				46	+	2.29	=	3.60
X3-1	12.52	9	0	48.30	+				48.3	+	2.29	=	3.66
Y1-1	12.45	9	0	52.00	+				52	+	3.39	=	4.84
Y2-1	12.45	9	0	52.00	+				52	+	3.39	=	4.84



Project: 19-07 Romine  
 Project #: 2019-07873  
 Location: Valley County, Idaho  
 Engineer: SB  
 Checker: KJ

## Seismic Shear Force Calculations

From 'ASCE7-10 Seismic Loading Analysis':

Wall Line	Roof (psf)	Area W (ft)	Area L (ft)	+	Floor (psf)	Area W (ft)	Area L (ft)	+	Wall Type	Wall (psf)	Wall Height (ft)	Perp Wall length (ft)	*C <sub>s</sub>	+	Shear upper (kips) =	Shear Force (kips)	Lateral Control
X1-2	70	28.3	52	+	39	0	0	+	OSB	12.0	10	28.3	.05Wp	+	=	2.77	Seismic
X2-2	70	28.3	52	+	39	0	0	+	OSB	12.0	10	28.3	.05Wp	+	=	2.77	Seismic
Y1-2	70	52	28.3	+	39	0	0	+	OSB	12.0	5.5	52	.05Wp	+	=	2.77	Wind
Y2-2	70	52	38.3	+	39	0	0	+	OSB	12.0	5.5	52	.05Wp	+	=	3.69	Seismic
X1-1	70	17.7	52	+	39	0	0	+	OSB	12.0	16	17.7	.05Wp	+	=	1.80	Seismic
X2-1	70	46	52	+	39	28.3	52	+	OSB	12.0	9	46	.05Wp	+	=	5.93	Seismic
X3-1	70	48.3	52	+	39	28.3	52	+	OSB	12.0	9	48.3	.05Wp	+	=	6.15	Seismic
Y1-1	70	52	17.7	+	39	52	28.3	+	OSB	12.0	9	52	.05Wp	+	=	3.36	Wind
Y2-1	70	52	46	+	39	52	28.3	+	OSB	12.0	9	52	.05Wp	+	=	5.96	Seismic



Project: 19-07 Romine  
 Project # : 2019-07873  
 Location: Valley County, Idaho  
 Engineer: SB  
 Checker: KJ

**Description: X1-2 Shear Wall**

**Perforated Shear Wall Calculation Sheet:**

This spreadsheet is made in conformance to the IBC Chapters 2305-2308 and AFPA's "SDPWS: Lateral Force Resisting Systems".

**Shear Wall Forces**

L =	52.00	ft	Total length of wall
L <sub>w</sub> =	52.00	ft	Total length of shear wall
H =	10.00	ft	Total length of full height segments
H' =	0.00	ft	height of shear wall
V <sub>1</sub> =	2767	lbs	Maximum opening height
W <sub>DL self</sub> =	119.8	plf	Total Seismic force at top of wall
W <sub>DL above</sub> =	68.00	plf	Self weight
	7/16	in	Applied dead load
	1/2	in	Prefered OSB thickness
	N	y/n	Prefered Gyp thickness
	N	y/n	Wall Connected to Concrete
	N	y/n	Wall Connected to Truss Heel
	N	y/n	Wall Connected to Gable / Drag Truss or Rim

Shearwall segments

52

**Unit Base Shear**

% <sub>fh</sub> = L <sub>w</sub> /L =	1.000	Percent of full height segments
% <sub>oh</sub> = H'/H =	0.000	Percent of maximum opening height
SCAF =	1.00	Shear capacity adjustment factors (NDS SDPWS Table )
V <sub>base</sub> = V <sub>1</sub> /L <sub>w</sub> =	53	Unit base shear
V <sub>req</sub> = V <sub>base</sub> /SCAF	53	Effective unit base shear
OTM =	27,669	Overturning moment of total length of wall

**Shear wall adjustment factor**

RM =	253,906	lb ft	Resisting moment of total length of wall
r =	1.0000		
C <sub>0</sub> =	1.0000		
	53	plf	Blocking Unit Shear
	53.21		Force Calculated
	2.86	ft	Min Shear Wall Segment

T = **Not Req'd** lbs

**OSB Wall Sheathing attachment**

Provide: 7/16" OSB W/ 8d Nails @ 6" O.C.

V<sub>a</sub>= 240

Provide: 7/16" OSB W/ 1 1/2 16 Gage Staples @ 6" O.C.

V<sub>a</sub>= 155

**W1**

**Blocking / Gable Truss Attachment**



Project: 19-07 Romine  
 Project # : 2019-07873  
 Location: Valley County, Idaho  
 Engineer: SB  
 Checker: KJ

**Description: X2-2 Shear Wall**

**Perforated Shear Wall Calculation Sheet:**

This spreadsheet is made in conformance to the IBC Chapters 2305-2308 and AFPA's "SDPWS: Lateral Force Resisting Systems".

**Shear Wall Forces**

	31.50	ft	Total length of wall
L =	31.50	ft	Total length of shear wall
L <sub>w</sub> =	19.48	ft	Total length of full height segments
H =	10.00	ft	height of shear wall
H' =	6.00	ft	Maximum opening height
V <sub>1</sub> =	2767	lbs	Total Seismic force at top of wall
W <sub>DL self</sub> =	119.8	plf	Self weight
W <sub>DL above</sub> =	68.00	plf	Applied dead load
	7/16	in	Prefered OSB thickness
	1/2	in	Prefered Gyp thickness
	N	y/n	Wall Connected to Concrete
	N	y/n	Wall Connected to Truss Heel
	N	y/n	Wall Connected to Gable / Drag Truss or Rim

Shearwall segments

5  
9  
5.48

**Unit Base Shear**

% <sub>fh</sub> = L <sub>w</sub> /L =	0.618	Percent of full height segments
% <sub>oh</sub> = H'/H =	0.600	Percent of maximum opening height
SCAF =	0.77	Shear capacity adjustment factors (NDS SDPWS Table )
V <sub>base</sub> = V <sub>1</sub> /L <sub>w</sub> =	142	plf Unit base shear
V <sub>req</sub> = V <sub>base</sub> /SCAF	185	plf Effective unit base shear
OTM =	36,115	lb ft Overturning moment of total length of wall

**Shear wall adjustment factor**

RM =	93,172	lb ft	Resisting moment of total length of wall
r =	0.7298		
C <sub>0</sub> =	0.7661		
	88	plf	Blocking Unit Shear
	185.40		Force Calculated
	2.86	ft	Min Shear Wall Segment

T = Not Req'd lbs

**OSB Wall Sheathing attachment**

Provide: 7/16" OSB W/ 8d Nails @ 6" O.C.

V<sub>a</sub>= 240

Provide: 7/16" OSB W/ 1 1/2 16 Gage Staples @ 4" O.C.

V<sub>a</sub>= 230

W1

**Blocking / Gable Truss Attachment**



Project: 19-07 Romine  
 Project # : 2019-07873  
 Location: Valley County, Idaho  
 Engineer: SB  
 Checker: KJ

**Description: Y1-2 Shear Wall**

**Perforated Shear Wall Calculation Sheet:**

This spreadsheet is made in conformance to the IBC Chapters 2305-2308 and AFPA's "SDPWS: Lateral Force Resisting Systems".

**Shear Wall Forces**

L =	23.30	ft	Total length of wall
L <sub>w</sub> =	23.30	ft	Total length of shear wall
H =	19.06	ft	Total length of full height segments
H'	10.00	ft	height of shear wall
V <sub>1</sub> =	7.00	ft	Maximum opening height
W <sub>DL self</sub> =	3386	lbs	Total Wind force at top of wall
W <sub>DL above</sub> =	119.8	plf	Self weight
	85.00	plf	Applied dead load
	7/16	in	Prefered OSB thickness
	1/2	in	Prefered Gyp thickness
	N	y/n	Wall Connected to Concrete
	N	y/n	Wall Connected to Truss Heel
	N	y/n	Wall Connected to Gable / Drag Truss or Rim

Shearwall segments

3.48  
12.5  
3.08

**Unit Base Shear**

% <sub>fh</sub> = L <sub>w</sub> /L =	0.818	Percent of full height segments
% <sub>oh</sub> = H'/H =	0.700	Percent of maximum opening height
SCAF =	0.83	Shear capacity adjustment factors (NDS SDPWS Table )
V <sub>base</sub> = V <sub>1</sub> /L <sub>w</sub> =	178	plf Unit base shear
V <sub>req</sub> = V <sub>base</sub> /SCAF	213	plf Effective unit base shear
OTM =	40,639	lb ft Overturning moment of total length of wall

**Shear wall adjustment factor**

RM =	55,592	lb ft	Resisting moment of total length of wall
r =	0.8653		
C <sub>0</sub> =	0.8332		
	145	plf	Blocking Unit Shear Force Calculated
	213.22		Min Shear Wall Segment

T = **382** lbs      Holdown **Intersecting wall**      Ta = **500**      Type **Misc**

**OSB Wall Sheathing attachment**

Provide: 7/16" OSB W/ 8d Nails @ 6" O.C.

Va= 336

Provide: 7/16" OSB W/ 1 1/2 16 Gage Staples @ 6" O.C.

Va= 217

**W1**

**Blocking / Gable Truss Attachment**



Project: 19-07 Romine  
 Project # : 2019-07873  
 Location: Valley County, Idaho  
 Engineer: SB  
 Checker: KJ

**Description: Y2-2 Shear Wall (3 PANELS)**

**Perforated Shear Wall Calculation Sheet:**

This spreadsheet is made in conformance to the IBC Chapters 2305-2308 and AFPA's "SDPWS: Lateral Force Resisting Systems".

**Shear Wall Forces**

L =	20.00	ft	Total length of wall
L <sub>w</sub> =	2.50	ft	Total length of shear wall
H =	2.50	ft	Total length of full height segments
H'	8.00	ft	height of shear wall
V <sub>1</sub> =	8.00	ft	Maximum opening height
W <sub>DL self</sub> =	1229	lbs	Total Seismic force at top of wall
W <sub>DL above</sub> =	95.84	plf	Self weight
	68.00	plf	Applied dead load
	7/16	in	Prefered OSB thickness
	1/2	in	Prefered Gyp thickness
	N	y/n	Wall Connected to Concrete
	N	y/n	Wall Connected to Truss Heel
	N	y/n	Wall Connected to Gable / Drag Truss or Rim

Shearwall segments

2.5

**Unit Base Shear**

% <sub>fh</sub> = L <sub>w</sub> /L =	1.000	Percent of full height segments	
% <sub>oh</sub> = H'/H =	1.000	Percent of maximum opening height	
SCAF =	1.00	Shear capacity adjustment factors (NDS SDPWS Table )	
V <sub>base</sub> = V <sub>1</sub> /L <sub>w</sub> =	491	plf	Unit base shear
V <sub>req</sub> = V <sub>base</sub> /SCAF	491	plf	Effective unit base shear
OTM =	9,828	lb ft	Overturning moment of shortest panel

**Shear wall adjustment factor**

RM =	512	lb ft	Resisting moment of shortest panel
r =	1.0000		
C <sub>0</sub> =	1.0000		
	184	plf	Blocking Unit Shear Force Calculated
	491.41		Min Shear Wall Segment

T = **3808** lbs      Holdown **Simpson MSTC52**      Ta **4235**      Type **Strap**

**OSB Wall Sheathing attachment**

Provide: 7/16" OSB W/ 8d Nails @ 2" O.C.

Va= 585

**W4**

**Blocking / Gable Truss Attachment**



Project: 19-07 Romine  
 Project # : 2019-07873  
 Location: Valley County, Idaho  
 Engineer: SB  
 Checker: KJ

**Description: X1-1 Shear Wall (4 PANELS)**

**Perforated Shear Wall Calculation Sheet:**

This spreadsheet is made in conformance to the IBC Chapters 2305-2308 and AFPA's "SDPWS: Lateral Force Resisting Systems".

**Shear Wall Forces**

	20.00	ft	Total length of wall
L =	8.00	ft	Total length of shear wall
L <sub>w</sub> =	8.00	ft	Total length of full height segments
H =	16.00	ft	height of shear wall
H' =	0.00	ft	Maximum opening height
V <sub>1</sub> =	449	lbs	Total Seismic force at top of wall
W <sub>DL self</sub> =	191.68	plf	Self weight
W <sub>DL above</sub> =	68.00	plf	Applied dead load
	7/16	in	Prefered OSB thickness
	1/2	in	Prefered Gyp thickness
	Y	y/n	Wall Connected to Concrete
	Y	y/n	Wall Connected to Truss Heel
	N	y/n	Wall Connected to Gable / Drag Truss or Rim

Shearwall segments

8

**Unit Base Shear**

% <sub>fh</sub> = L <sub>w</sub> /L =	1.000		Percent of full height segments
% <sub>oh</sub> = H'/H =	0.000		Percent of maximum opening height
SCAF =	1.00		Shear capacity adjustment factors (NDS SDPWS Table )
V <sub>base</sub> = V <sub>1</sub> /L <sub>w</sub> =	56	plf	Unit base shear
V <sub>req</sub> = V <sub>base</sub> /SCAF	56	plf	Effective unit base shear
OTM =	7,180	lb ft	Overturning moment of total length of wall

**Shear wall adjustment factor**

RM =	8,310	lb ft	Resisting moment of total length of wall
r =	1.0000		
C <sub>0</sub> =	1.0000		
	90	plf	Blocking Unit Shear Force Calculated
	56.10		Min Shear Wall Segment

T = 274 lbs      Holdown **Intersecting wall**      Ta = 500      Type **Misc**

**Shear Transfer to Concrete:**

1/2 Anchor Bolts @ 72" O.C.      (2) Minimum

**OSB Wall Sheathing attachment**

Provide: 7/16" OSB W/ 8d Nails @ 6" O.C.

Va= 240

Provide: 7/16" OSB W/ 1 1/2 16 Gage Staples @ 6" O.C.

Va= 155

**W1**

**Blocking / Gable Truss Attachment**

"No Blocking Required"



Project: 19-07 Romine  
 Project # : 2019-07873  
 Location: Valley County, Idaho  
 Engineer: SB  
 Checker: KJ

**Description: X2-1 Shear Wall**

**Perforated Shear Wall Calculation Sheet:**

This spreadsheet is made in conformance to the IBC Chapters 2305-2308 and AFPA's "SDPWS: Lateral Force Resisting Systems".

**Shear Wall Forces**

L =	20.00	ft	Total length of wall
L <sub>w</sub> =	20.00	ft	Total shear wall length to Small
H =	33.00	ft	Total length of full height segments
H'	9.00	ft	height of shear wall
V <sub>1</sub> =	9.00	ft	Maximum opening height
W <sub>DL self</sub> =	5925	lbs	Total Seismic force at top of wall
W <sub>DL above</sub> =	107.82	plf	Self weight
	68.00	plf	Applied dead load
	7/16	in	Prefered OSB thickness
	1/2	in	Prefered Gyp thickness
	Y	y/n	Wall Connected to Concrete
	Y	y/n	Wall Connected to Truss Heel
	Y	y/n	Wall Connected to Gable / Drag Truss or Rim

Shearwall segments

11.5  
13.5  
8

**Unit Base Shear**

% <sub>fh</sub> = L <sub>w</sub> /L =	1.650	Percent of full height segments
% <sub>oh</sub> = H'/H =	1.000	Percent of maximum opening height
SCAF =	-3.33	Shear capacity adjustment factors (NDS SDPWS Table )
V <sub>base</sub> = V <sub>1</sub> /L <sub>w</sub> =	180	Unit base shear
V <sub>req</sub> = V <sub>base</sub> /SCAF =	-54	Effective unit base shear
OTM =	-15,999	Overturning moment of total length of wall

**Shear wall adjustment factor**

RM =	35,164	lb ft	Resisting moment of total length of wall
r =	1.6500		
C <sub>0</sub> =	-3.3333		
	296	plf	Blocking Unit Shear Force Calculated
	2.57	ft	Min Shear Wall Segment

T = **Not Req'd** lbs

**Shear Transfer to Concrete:**

1/2 Anchor Bolts @ 48" O.C. (6) Minimum

**OSB Wall Sheathing attachment**

Provide: 7/16" OSB W/ 8d Nails @ 6" O.C.

V<sub>a</sub> = 240

Provide: 7/16" OSB W/ 1 1/2 16 Gage Staples @ 6" O.C.

V<sub>a</sub> = 155

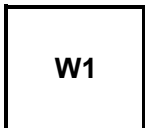

**Blocking / Gable Truss Attachment**

Provide Blkg Every Other Bay: W/ (6) 10d's Toenails at Each

Nail Gable Truss to Top Plate With: W/ 10d's @ 6" O.C. to Top Plate



Project: 19-07 Romine  
 Project # : 2019-07873  
 Location: Valley County, Idaho  
 Engineer: SB  
 Checker: KJ

**Description: X3-1 Shear Wall**

**Perforated Shear Wall Calculation Sheet:**

This spreadsheet is made in conformance to the IBC Chapters 2305-2308 and AFPA's "SDPWS: Lateral Force Resisting Systems".

**Shear Wall Forces**

L =	20.00	ft	Total length of wall
L <sub>w</sub> =	20.00	ft	Total shear wall length to Small
H =	34.50	ft	Total length of full height segments
H'	9.00	ft	height of shear wall
V <sub>1</sub> =	7.00	ft	Maximum opening height
W <sub>DL self</sub> =	6149	lbs	Total Seismic force at top of wall
W <sub>DL above</sub> =	107.82	plf	Self weight
	272.00	plf	Applied dead load
	7/16	in	Prefered OSB thickness
	1/2	in	Prefered Gyp thickness
	Y	y/n	Wall Connected to Concrete
	N	y/n	Wall Connected to Truss Heel
	Y	y/n	Wall Connected to Gable / Drag Truss or Rim

Shearwall segments

5
7
9
8.83
4.67

**Unit Base Shear**

% <sub>fh</sub> = L <sub>w</sub> /L =	1.725	Percent of full height segments
% <sub>oh</sub> = H'/H =	0.778	Percent of maximum opening height
SCAF =	1.00	Shear capacity adjustment factors (NDS SDPWS Table )
V <sub>base</sub> = V <sub>1</sub> /L <sub>w</sub> =	178	plf Unit base shear
V <sub>req</sub> = V <sub>base</sub> /SCAF	178	plf Effective unit base shear
OTM =	55,341	lb ft Overturning moment of total length of wall

**Shear wall adjustment factor**

RM =	75,964	lb ft	Resisting moment of total length of wall
r =	1.4856		
C <sub>0</sub> =	30.0000		
	307	plf	Blocking Unit Shear Force Calculated
	178.23		Min Shear Wall Segment

T = **283** lbs      **Intersecting wall**      Ta = **500**      Type **Misc**

**Shear Transfer to Concrete:**

1/2 Anchor Bolts @ 48" O.C.      (6) Minimum

**OSB Wall Sheathing attachment**

Provide: 7/16" OSB W/ 8d Nails @ 6" O.C.

Va = 240

Provide: 7/16" OSB W/ 1 1/2 16 Gage Staples @ 4" O.C.

Va = 230



**Blocking / Gable Truss Attachment**

Nail Gable Truss to Top Plate With:      W/ 10d's @ 4" O.C.      to Top Plate



Project: 19-07 Romine  
 Project # : 2019-07873  
 Location: Valley County, Idaho  
 Engineer: SB  
 Checker: KJ

**Description: Y1-1 Shear Wall**

**Perforated Shear Wall Calculation Sheet:**

This spreadsheet is made in conformance to the IBC Chapters 2305-2308 and AFPA's "SDPWS: Lateral Force Resisting Systems".

**Shear Wall Forces**

	46.00	ft	Total length of wall
L =	46.00	ft	Total length of shear wall
L <sub>w</sub> =	27.81	ft	Total length of full height segments
H =	9.00	ft	height of shear wall
H' =	7.00	ft	Maximum opening height
V <sub>1</sub> =	4843	lbs	Total Wind force at top of wall
W <sub>DL self</sub> =	107.82	plf	Self weight
W <sub>DL above</sub> =	188.00	plf	Applied dead load
	7/16	in	Prefered OSB thickness
	1/2	in	Prefered Gyp thickness
	Y	y/n	Wall Connected to Concrete
	Y	y/n	Wall Connected to Truss Heel
	Y	y/n	Wall Connected to Gable / Drag Truss or Rim

Shearwall segments

3.75
4.33
7.75
5.5
6.48

**Unit Base Shear**

% <sub>fh</sub> = L <sub>w</sub> /L =	0.605	Percent of full height segments
% <sub>oh</sub> = H'/H =	0.778	Percent of maximum opening height
SCAF =	0.65	Shear capacity adjustment factors (NDS SDPWS Table )
V <sub>base</sub> = V <sub>1</sub> /L <sub>w</sub> =	174	plf Unit base shear
V <sub>req</sub> = V <sub>base</sub> /SCAF	266	plf Effective unit base shear
OTM =	66,564	lb ft Overturning moment of total length of wall

**Shear wall adjustment factor**

RM =	312,978	lb ft	Resisting moment of total length of wall
r =	0.6628		
C <sub>o</sub> =	0.6548		
	105	plf	Blocking Unit Shear Force Calculated
	265.95		
	2.57	ft	Min Shear Wall Segment

T = **Not Req'd** lbs

**Shear Transfer to Concrete:**

1/2 Anchor Bolts @ 72" O.C. (5) Minimum

**OSB Wall Sheathing attachment**

Provide: 7/16" OSB W/ 8d Nails @ 6" O.C.

V<sub>a</sub>= 336

Provide: 7/16" OSB W/ 1 1/2 16 Gage Staples @ 4" O.C.

V<sub>a</sub>= 322

**W1**

**Blocking / Gable Truss Attachment**

"No Blocking Required"

"Typ. Gable Nailing"



Project: 19-07 Romine  
 Project # : 2019-07873  
 Location: Valley County, Idaho  
 Engineer: SB  
 Checker: KJ

**Description: Y2-1 Shear Wall (2 PANELS)**

**Perforated Shear Wall Calculation Sheet:**

This spreadsheet is made in conformance to the IBC Chapters 2305-2308 and AFPA's "SDPWS: Lateral Force Resisting Systems".

**Shear Wall Forces**

	17.70	ft	Total length of wall
L =	2.90	ft	Total length of shear wall
L <sub>w</sub> =	2.90	ft	Total length of full height segments
H =	16.00	ft	height of shear wall
H' =	0.00	ft	Maximum opening height
V <sub>1</sub> =	1877	lbs	Total Seismic force at top of wall
W <sub>DL self</sub> =	191.68	plf	Self weight
W <sub>DL above</sub> =	68.00	plf	Applied dead load
	7/16	in	Prefered OSB thickness
	1/2	in	Prefered Gyp thickness
	Y	y/n	Wall Connected to Concrete
	Y	y/n	Wall Connected to Truss Heel
	N	y/n	Wall Connected to Gable / Drag Truss or Rim

Shearwall segments

2.9

**Unit Base Shear**

% <sub>fh</sub> = L <sub>w</sub> /L =	1.000	Percent of full height segments
% <sub>oh</sub> = H'/H =	0.000	Percent of maximum opening height
SCAF =	1.00	Shear capacity adjustment factors (NDS SDPWS Table )
V <sub>base</sub> = V <sub>1</sub> /L <sub>w</sub> =	647	plf Unit base shear
V <sub>req</sub> = V <sub>base</sub> /SCAF	647	plf Effective unit base shear
OTM =	30,030	lb ft Overturning moment of shortest panel

**Shear wall adjustment factor**

RM =	1,092	lb ft	Resisting moment of shortest panel
r =	1.0000		
C <sub>0</sub> =	1.0000		
	212	plf	Blocking Unit Shear
	647.20		Force Calculated
	1.33	ft	Min Shear Wall Segment

T = 10129 lbs      Holdown **Simpson HDU14**      Ta 14445      Type **Holdown**

**Truss Braced Frame**

Provide: (2) Truss Braced Frames

Va = 2950# EA. 5900# Total

**Blocking / Gable Truss Attachment**

Provide Blkg Every Other Bay:

W/ (6) 10d's Toenails at Each



Project: 19-07 Romine  
 Project # : 2019-07873  
 Location: Valley County, Idaho  
 Engineer: SB  
 Checker: KJ

**Description: Y2-1 (2) Shear Wall (3 PANELS)**

**Perforated Shear Wall Calculation Sheet:**

This spreadsheet is made in conformance to the IBC Chapters 2305-2308 and AFPA's "SDPWS: Lateral Force Resisting Systems".

**Shear Wall Forces**

L =	23.30	ft	Total length of wall
L <sub>w</sub> =	2.90	ft	Total length of shear wall
H =	2.90	ft	Total length of full height segments
H'	9.00	ft	height of shear wall
V <sub>1</sub> =	8.00	ft	Maximum opening height
W <sub>DL self</sub> =	1251	lbs	Total Seismic force at top of wall
W <sub>DL above</sub> =	107.82	plf	Self weight
	68.00	plf	Applied dead load
	7/16	in	Prefered OSB thickness
	1/2	in	Prefered Gyp thickness
	Y	y/n	Wall Connected to Concrete
	N	y/n	Wall Connected to Truss Heel
	Y	y/n	Wall Connected to Gable / Drag Truss or Rim

Shearwall segments

2.9

**Unit Base Shear**

% <sub>fh</sub> = L <sub>w</sub> /L =	1.000	Percent of full height segments
% <sub>oh</sub> = H'/H =	0.889	Percent of maximum opening height
SCAF =	1.00	Shear capacity adjustment factors (NDS SDPWS Table )
V <sub>base</sub> = V <sub>1</sub> /L <sub>w</sub> =	431	plf Unit base shear
V <sub>req</sub> = V <sub>base</sub> /SCAF	431	plf Effective unit base shear
OTM =	11,261	lb ft Overturning moment of total length of wall

**Shear wall adjustment factor**

RM =	739	lb ft	Resisting moment of total length of wall
r =	1.0000		
C <sub>0</sub> =	1.0000		
	161	plf	Blocking Unit Shear Force Calculated
	431.46		Min Shear Wall Segment

T =	3730	lbs	Holdown	Ta	5645	Type	Holdown
			Simpson HDU5				
			OR:				
			Simpson STHD14	5150			Strap Tie

**Shear Transfer to Concrete:**

1/2 Anchor Bolts @ 72" O.C. (2) Minimum

**OSB Wall Sheathing attachment**

Provide: 7/16" OSB W/ 8d Nails @ 3" O.C.

Va= 450



**Blocking / Gable Truss Attachment**

Nail Gable Truss to Top Plate With: W/ 10d's @ 6" O.C. to Top Plate

Level, Floor: Joist  
 1 piece(s) 14" TJI® 210 @ 24" OC

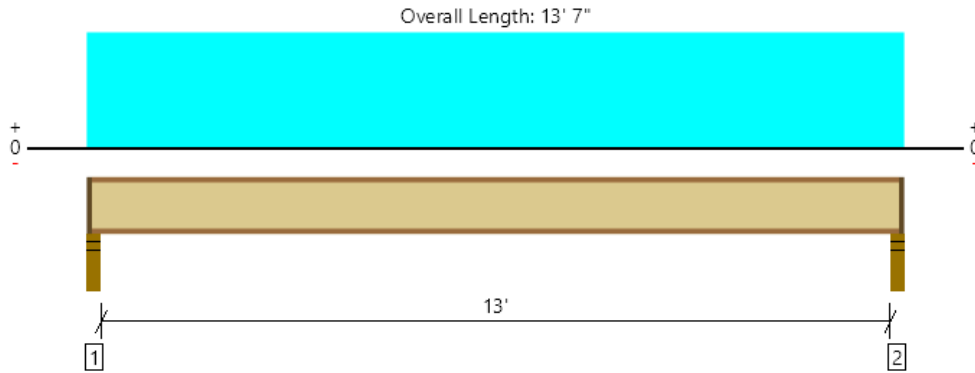

All locations are measured from the outside face of left support (or left cantilever end). All dimensions are horizontal.

Design Results	Actual @ Location	Allowed	Result	LDF	Load: Combination (Pattern)
Member Reaction (lbs)	883 @ 2 1/2"	1134 (2.25")	Passed (78%)	1.00	1.0 D + 1.0 L (All Spans)
Shear (lbs)	858 @ 3 1/2"	1945	Passed (44%)	1.00	1.0 D + 1.0 L (All Spans)
Moment (Ft-lbs)	2860 @ 6' 9 1/2"	4490	Passed (64%)	1.00	1.0 D + 1.0 L (All Spans)
Live Load Defl. (in)	0.118 @ 6' 9 1/2"	0.329	Passed (L/999+)	--	1.0 D + 1.0 L (All Spans)
Total Load Defl. (in)	0.194 @ 6' 9 1/2"	0.658	Passed (L/812)	--	1.0 D + 1.0 L (All Spans)
TJ-Pro™ Rating	52	40	Passed	--	--

System : Floor  
 Member Type : Joist  
 Building Use : Residential  
 Building Code : IBC 2015  
 Design Methodology : ASD

- Deflection criteria: LL (L/480) and TL (L/240).
- Top Edge Bracing (Lu): Top compression edge must be braced at 4' 9" o/c unless detailed otherwise.
- Bottom Edge Bracing (Lu): Bottom compression edge must be braced at 13' 5" o/c unless detailed otherwise.
- A structural analysis of the deck has not been performed.
- Deflection analysis is based on composite action with a single layer of 23/32" Weyerhaeuser Edge™ Panel (24" Span Rating) that is glued and nailed down.
- Additional considerations for the TJ-Pro™ Rating include: None.

Supports	Bearing Length			Loads to Supports (lbs)			Accessories
	Total	Available	Required	Dead	Floor Live	Total	
1 - Stud wall - DF	3.50"	2.25"	1.75"	353	543	896	1 1/4" Rim Board
2 - Stud wall - DF	3.50"	2.25"	1.75"	353	543	896	1 1/4" Rim Board

• Rim Board is assumed to carry all loads applied directly above it, bypassing the member being designed.

Vertical Load	Location (Side)	Spacing	Dead (0.90)	Floor Live (1.00)	Comments
1 - Uniform (PSF)	0 to 13' 7"	24"	26.0	40.0	Default Load

**Weyerhaeuser Notes**

Weyerhaeuser warrants that the sizing of its products will be in accordance with Weyerhaeuser product design criteria and published design values. Weyerhaeuser expressly disclaims any other warranties related to the software. Use of this software is not intended to circumvent the need for a design professional as determined by the authority having jurisdiction. The designer of record, builder or framer is responsible to assure that this calculation is compatible with the overall project. Accessories (Rim Board, Blocking Panels and Squash Blocks) are not designed by this software. Products manufactured at Weyerhaeuser facilities are third-party certified to sustainable forestry standards. Weyerhaeuser Engineered Lumber Products have been evaluated by ICC-ES under evaluation reports ESR-1153 and ESR-1387 and/or tested in accordance with applicable ASTM standards. For current code evaluation reports, Weyerhaeuser product literature and installation details refer to [www.weyerhaeuser.com/woodproducts/document-library](http://www.weyerhaeuser.com/woodproducts/document-library).

The product application, input design loads, dimensions and support information have been provided by ForteWEB Software Operator



ForteWEB Software Operator	Job Notes
Spencer Bradshaw Performance Engineers (208) 475-0026 Sbradshaw@Inteframe.com	

Level, Copy of Floor: Joist  
 1 piece(s) 9 1/2" TJI® 210 @ 24" OC

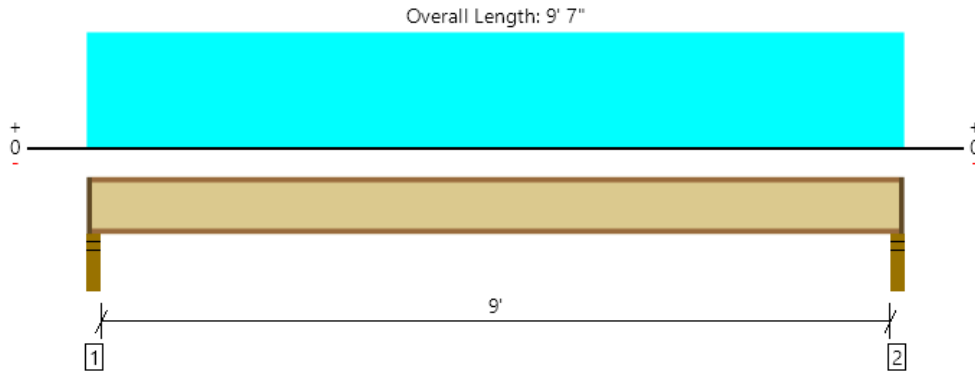

All locations are measured from the outside face of left support (or left cantilever end). All dimensions are horizontal.

Design Results	Actual @ Location	Allowed	Result	LDF	Load: Combination (Pattern)
Member Reaction (lbs)	619 @ 2 1/2"	1134 (2.25")	Passed (55%)	1.00	1.0 D + 1.0 L (All Spans)
Shear (lbs)	594 @ 3 1/2"	1330	Passed (45%)	1.00	1.0 D + 1.0 L (All Spans)
Moment (Ft-lbs)	1386 @ 4' 9 1/2"	3000	Passed (46%)	1.00	1.0 D + 1.0 L (All Spans)
Live Load Defl. (in)	0.071 @ 4' 9 1/2"	0.229	Passed (L/999+)	--	1.0 D + 1.0 L (All Spans)
Total Load Defl. (in)	0.116 @ 4' 9 1/2"	0.458	Passed (L/945)	--	1.0 D + 1.0 L (All Spans)
TJ-Pro™ Rating	52	40	Passed	--	--

System : Floor  
 Member Type : Joist  
 Building Use : Residential  
 Building Code : IBC 2015  
 Design Methodology : ASD

- Deflection criteria: LL (L/480) and TL (L/240).
- Top Edge Bracing (Lu): Top compression edge must be braced at 5' 6" o/c unless detailed otherwise.
- Bottom Edge Bracing (Lu): Bottom compression edge must be braced at 9' 5" o/c unless detailed otherwise.
- A structural analysis of the deck has not been performed.
- Deflection analysis is based on composite action with a single layer of 23/32" Weyerhaeuser Edge™ Panel (24" Span Rating) that is glued and nailed down.
- Additional considerations for the TJ-Pro™ Rating include: None.

Supports	Bearing Length			Loads to Supports (lbs)			Accessories
	Total	Available	Required	Dead	Floor Live	Total	
1 - Stud wall - DF	3.50"	2.25"	1.75"	249	383	632	1 1/4" Rim Board
2 - Stud wall - DF	3.50"	2.25"	1.75"	249	383	632	1 1/4" Rim Board

• Rim Board is assumed to carry all loads applied directly above it, bypassing the member being designed.

Vertical Load	Location (Side)	Spacing	Dead (0.90)	Floor Live (1.00)	Comments
1 - Uniform (PSF)	0 to 9' 7"	24"	26.0	40.0	Default Load

**Weyerhaeuser Notes**

Weyerhaeuser warrants that the sizing of its products will be in accordance with Weyerhaeuser product design criteria and published design values. Weyerhaeuser expressly disclaims any other warranties related to the software. Use of this software is not intended to circumvent the need for a design professional as determined by the authority having jurisdiction. The designer of record, builder or framer is responsible to assure that this calculation is compatible with the overall project. Accessories (Rim Board, Blocking Panels and Squash Blocks) are not designed by this software. Products manufactured at Weyerhaeuser facilities are third-party certified to sustainable forestry standards. Weyerhaeuser Engineered Lumber Products have been evaluated by ICC-ES under evaluation reports ESR-1153 and ESR-1387 and/or tested in accordance with applicable ASTM standards. For current code evaluation reports, Weyerhaeuser product literature and installation details refer to [www.weyerhaeuser.com/woodproducts/document-library](http://www.weyerhaeuser.com/woodproducts/document-library).

The product application, input design loads, dimensions and support information have been provided by ForteWEB Software Operator



ForteWEB Software Operator	Job Notes
Spencer Bradshaw Performance Engineers (208) 475-0026 Sbradshaw@Inteframe.com	



**Wood Beam**

File = V:\\_PROJE-12019\205717-1206BC7-1\CALCUL-105 Beams.ec6 .  
Software copyright ENERCALC, INC. 1983-2018, Build:10.18.11.30 .

Lic. # : KW-06007473

Licensee : SHAWN REEDER

Description : Stuc. Fascia

**CODE REFERENCES**

Calculations per NDS 2015, IBC 2015, CBC 2016, ASCE 7-10  
Load Combination Set : IBC 2015

**Material Properties**

Analysis Method : Allowable Stress Design	Fb +	2,600.0 psi	E : Modulus of Elasticity
Load Combination IBC 2015	Fb -	2,600.0 psi	Ebend- xx
	Fc - Prll	2,510.0 psi	Eminbend - xx
Wood Species : Trus Joist	Fc - Perp	750.0 psi	
Wood Grade : MicroLam LVL 2.0 E	Fv	285.0 psi	Density
	Ft	1,555.0 psi	42.010pcf
Beam Bracing : Beam is Fully Braced against lateral-torsional buckling			

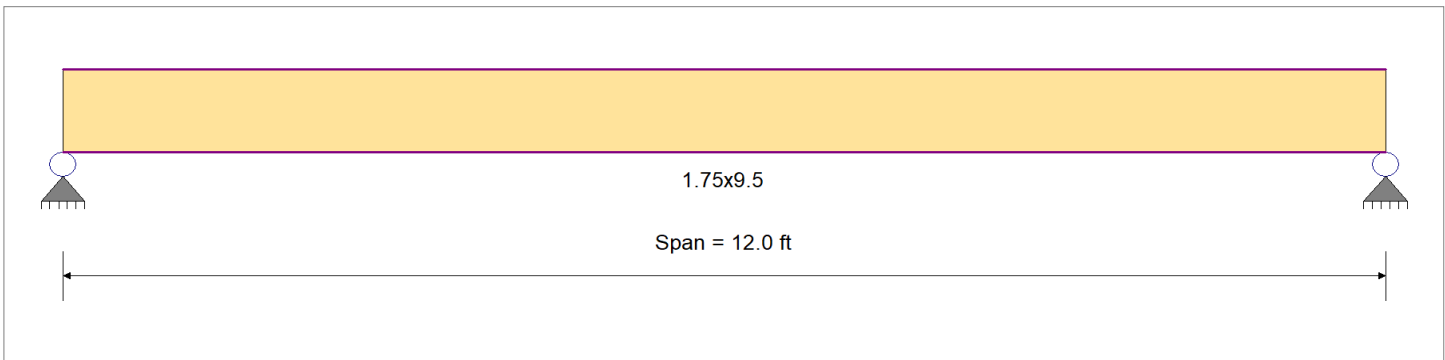

**Applied Loads**

Service loads entered. Load Factors will be applied for calculations.

**DESIGN SUMMARY**

**Design OK**

Maximum Bending Stress Ratio =	<b>0.588</b> : 1	Maximum Shear Stress Ratio =	<b>0.372</b> : 1
Section used for this span	<b>1.75x9.5</b>	Section used for this span	<b>1.75x9.5</b>
fb : Actual =	1,758.17 psi	fv : Actual =	121.96 psi
FB : Allowable =	2,990.00 psi	Fv : Allowable =	327.75 psi
Load Combination =	+D+S+H	Load Combination =	+D+S+H
Location of maximum on span =	6.920ft	Location of maximum on span =	11.212 ft
Span # where maximum occurs =	Span # 1	Span # where maximum occurs =	Span # 1
<b>Maximum Deflection</b>			
Max Downward Transient Deflection	0.352 in	Ratio =	408 >=360
Max Upward Transient Deflection	0.000 in	Ratio =	0 <360
Max Downward Total Deflection	0.392 in	Ratio =	367 >=180
Max Upward Total Deflection	0.000 in	Ratio =	0 <180

**Maximum Forces & Stresses for Load Combinations**

Load Combination	Segment Length	Span #	Max Stress Ratios								Moment Values			Shear Values						
			M	V	C <sub>d</sub>	C <sub>FV</sub>	C <sub>i</sub>	C <sub>r</sub>	C <sub>m</sub>	C <sub>t</sub>	C <sub>L</sub>	M	fb	F'b	V	fv	F'v			
+D+H	Length = 12.0 ft	1	0.076	0.048	0.90	1.000	1.00	1.00	1.00	1.00	1.00	0.39	178.98	2340.00	0.00	0.00	0.00	0.00	0.00	256.50
+D+L+H	Length = 12.0 ft	1	0.069	0.044	1.00	1.000	1.00	1.00	1.00	1.00	1.00	0.39	178.98	2600.00	0.00	0.00	0.00	0.00	0.00	285.00
+D+Lr+H	Length = 12.0 ft	1	0.055	0.035	1.25	1.000	1.00	1.00	1.00	1.00	1.00	0.39	178.98	3250.00	0.00	0.00	0.00	0.00	0.00	356.25
+D+S+H	Length = 12.0 ft	1	0.588	0.372	1.15	1.000	1.00	1.00	1.00	1.00	1.00	3.86	1,758.17	2990.00	0.00	0.00	0.00	0.00	0.00	0.00
+D+0.750Lr+0.750L+H	Length = 12.0 ft	1	0.055	0.035	1.25	1.000	1.00	1.00	1.00	1.00	1.00	0.39	178.98	3250.00	0.00	0.00	0.00	0.00	0.00	356.25
+D+0.750L+0.750S+H	Length = 12.0 ft	1	0.456	0.289	1.15	1.000	1.00	1.00	1.00	1.00	1.00	2.99	1,363.38	2990.00	0.00	0.00	0.00	0.00	0.00	327.75
+D+0.60W+H						1.000	1.00	1.00	1.00	1.00	1.00			0.00	0.00	0.00	0.00	0.00	0.00	0.00



Performance Engineers  
1102 N. Franklin Blvd  
Nampa, ID 83687

Project Title:  
Engineer:  
Project ID:  
Project Descr:

**Wood Beam**

File = V:\\_PROJE~12019\205717~1\206BC7~1\CALCUL~105 Beams.ec6 .  
Software copyright ENERCALC, INC. 1983-2018, Build:10.18.11.30 .

Lic. # : KW-06007473

Licensee : SHAWN REEDER

Description : Stuc. Fascia

Load Combination	Segment Length	Span #	Max Stress Ratios								Moment Values			Shear Values			
			M	V	C <sub>d</sub>	C <sub>F/V</sub>	C <sub>i</sub>	C <sub>r</sub>	C <sub>m</sub>	C <sub>t</sub>	C <sub>L</sub>	M	fb	F'b	V	fv	Fv
Length = 12.0 ft	1	0.043	0.027	1.60	1.000	1.00	1.00	1.00	1.00	1.00	1.00	0.39	178.98	4160.00	0.14	12.41	456.00
+D+0.70E+H					1.000	1.00	1.00	1.00	1.00	1.00	1.00			0.00	0.00	0.00	0.00
Length = 12.0 ft	1	0.043	0.027	1.60	1.000	1.00	1.00	1.00	1.00	1.00	1.00	0.39	178.98	4160.00	0.14	12.41	456.00
+D+0.750Lr+0.750L+0.450W+H					1.000	1.00	1.00	1.00	1.00	1.00	1.00			0.00	0.00	0.00	0.00
Length = 12.0 ft	1	0.043	0.027	1.60	1.000	1.00	1.00	1.00	1.00	1.00	1.00	0.39	178.98	4160.00	0.14	12.41	456.00
+D+0.750L+0.750S+0.450W+H					1.000	1.00	1.00	1.00	1.00	1.00	1.00			0.00	0.00	0.00	0.00
Length = 12.0 ft	1	0.328	0.207	1.60	1.000	1.00	1.00	1.00	1.00	1.00	1.00	2.99	1,363.38	4160.00	1.05	94.57	456.00
+D+0.750L+0.750S+0.5250E+H					1.000	1.00	1.00	1.00	1.00	1.00	1.00			0.00	0.00	0.00	0.00
Length = 12.0 ft	1	0.328	0.207	1.60	1.000	1.00	1.00	1.00	1.00	1.00	1.00	2.99	1,363.38	4160.00	1.05	94.57	456.00
+0.60D+0.60W+0.60H					1.000	1.00	1.00	1.00	1.00	1.00	1.00			0.00	0.00	0.00	0.00
Length = 12.0 ft	1	0.026	0.016	1.60	1.000	1.00	1.00	1.00	1.00	1.00	1.00	0.24	107.39	4160.00	0.08	7.45	456.00
+0.60D+0.70E+0.60H					1.000	1.00	1.00	1.00	1.00	1.00	1.00			0.00	0.00	0.00	0.00
Length = 12.0 ft	1	0.026	0.016	1.60	1.000	1.00	1.00	1.00	1.00	1.00	1.00	0.24	107.39	4160.00	0.08	7.45	456.00

**Overall Maximum Deflections**

Load Combination	Span	Max. "-" Defl	Location in Span	Load Combination	Max. "+" Defl	Location in Span
+D+S+H	1	0.3923	6.263		0.0000	0.000

**Vertical Reactions**

Support notation : Far left is #1

Values in KIPS

Load Combination	Support 1	Support 2
Overall MAXimum	0.835	1.670
Overall MINimum	0.750	1.500
+D+H	0.085	0.170
+D+L+H	0.085	0.170
+D+Lr+H	0.085	0.170
+D+S+H	0.835	1.670
+D+0.750Lr+0.750L+H	0.085	0.170
+D+0.750L+0.750S+H	0.648	1.295
+D+0.60W+H	0.085	0.170
+D+0.70E+H	0.085	0.170
+D+0.750Lr+0.750L+0.450W+H	0.085	0.170
+D+0.750L+0.750S+0.450W+H	0.648	1.295
+D+0.750L+0.750S+0.5250E+H	0.648	1.295
+0.60D+0.60W+0.60H	0.051	0.102
+0.60D+0.70E+0.60H	0.051	0.102
D Only	0.085	0.170
Lr Only		
L Only		
S Only	0.750	1.500
W Only		
E Only		
H Only		



**Wood Beam**

File = V:\\_PROJE-12019\205717-1206BC7-1\CALCUL-105 Beams.ec6 .  
Software copyright ENERCALC, INC. 1983-2018, Build:10.18.11.30 .

Lic. # : KW-06007473

Licensee : SHAWN REEDER

Description : Stuc. Fascia 2

**CODE REFERENCES**

Calculations per NDS 2015, IBC 2015, CBC 2016, ASCE 7-10  
Load Combination Set : IBC 2015

**Material Properties**

Analysis Method : Allowable Stress Design	Fb +	2,600.0 psi	E : Modulus of Elasticity
Load Combination IBC 2015	Fb -	2,600.0 psi	Ebend- xx
	Fc - Prll	2,510.0 psi	Eminbend - xx
Wood Species : Trus Joist	Fc - Perp	750.0 psi	
Wood Grade : MicroLam LVL 2.0 E	Fv	285.0 psi	
	Ft	1,555.0 psi	Density
Beam Bracing : Beam is Fully Braced against lateral-torsional buckling			42.010pcf

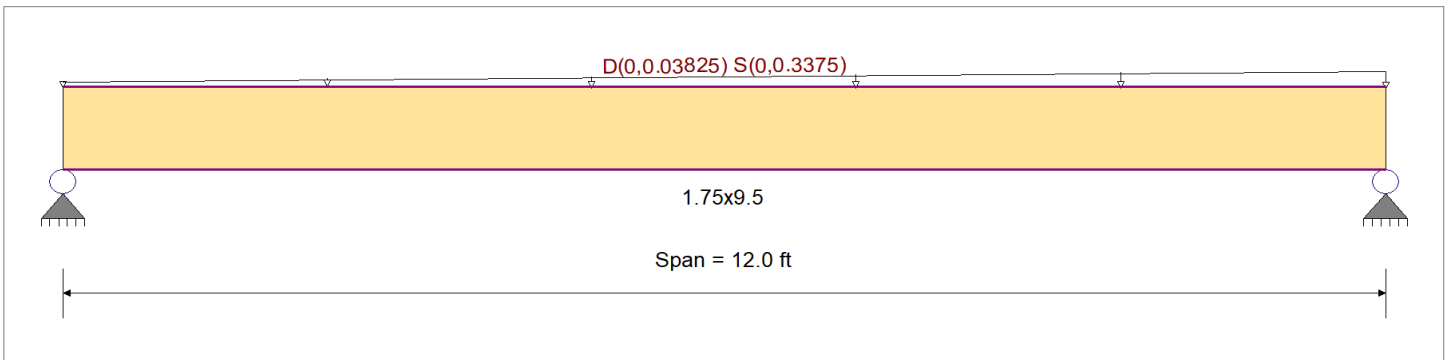

**Applied Loads**

Service loads entered. Load Factors will be applied for calculations.

Load for Span Number 1

Varying Uniform Load : D= 0.0170->0.0170, S= 0.150->0.150 ksf, Extent = 0.0 -->> 12.0 ft, Trib Width = 0.0->2.250 ft, (Roof)

**DESIGN SUMMARY**

**Design OK**

Maximum Bending Stress Ratio =	<b>0.529</b> : 1	Maximum Shear Stress Ratio =	<b>0.335</b> : 1
Section used for this span	<b>1.75x9.5</b>	Section used for this span	<b>1.75x9.5</b>
fb : Actual =	1,582.36psi	fv : Actual =	109.76 psi
FB : Allowable =	2,990.00psi	Fv : Allowable =	327.75 psi
Load Combination	+D+S+H	Load Combination	+D+S+H
Location of maximum on span	6.920ft	Location of maximum on span	11.212 ft
Span # where maximum occurs	Span # 1	Span # where maximum occurs	Span # 1
<b>Maximum Deflection</b>			
Max Downward Transient Deflection	0.317 in	Ratio =	454 >=360
Max Upward Transient Deflection	0.000 in	Ratio =	0 <360
Max Downward Total Deflection	0.353 in	Ratio =	407 >=180
Max Upward Total Deflection	0.000 in	Ratio =	0 <180

**Maximum Forces & Stresses for Load Combinations**

Load Combination	Segment Length	Span #	Max Stress Ratios								Moment Values			Shear Values						
			M	V	C <sub>d</sub>	C <sub>F/V</sub>	C <sub>i</sub>	C <sub>r</sub>	C <sub>m</sub>	C <sub>t</sub>	C <sub>L</sub>	M	fb	F'b	V	fv	F'v			
+D+H	Length = 12.0 ft	1	0.069	0.044	0.90	1.000	1.00	1.00	1.00	1.00	1.00	0.35	161.08	2340.00	0.00	0.00	0.00	0.00	0.00	256.50
+D+L+H	Length = 12.0 ft	1	0.062	0.039	1.00	1.000	1.00	1.00	1.00	1.00	1.00	0.35	161.08	2600.00	0.00	0.00	0.00	0.00	0.00	0.00
+D+Lr+H	Length = 12.0 ft	1	0.050	0.031	1.25	1.000	1.00	1.00	1.00	1.00	1.00	0.35	161.08	3250.00	0.00	0.00	0.00	0.00	0.00	0.00
+D+S+H	Length = 12.0 ft	1	0.529	0.335	1.15	1.000	1.00	1.00	1.00	1.00	1.00	3.47	1,582.36	2990.00	0.00	0.00	0.00	1.22	109.76	327.75
+D+0.750Lr+0.750L+H						1.000	1.00	1.00	1.00	1.00	1.00			0.00			0.00	0.00	0.00	0.00



Performance Engineers  
1102 N. Franklin Blvd  
Nampa, ID 83687

Project Title:  
Engineer:  
Project ID:  
Project Descr:

**Wood Beam**

File = V:\\_PROJE~1\2019\205717~1\206BC7~1\CALCUL~1\05 Beams.ec6 .  
Software copyright ENERCALC, INC. 1983-2018, Build:10.18.11.30 .

Lic. # : KW-06007473

Licensee : SHAWN REEDER

Description : Stuc. Fascia 2

Load Combination	Segment Length	Span #	Max Stress Ratios								Moment Values			Shear Values		
			M	V	C <sub>d</sub>	C <sub>F/V</sub>	C <sub>i</sub>	C <sub>r</sub>	C <sub>m</sub>	C <sub>t</sub>	C <sub>L</sub>	M	fb	F'b	V	fv
Length = 12.0 ft	1	0.050	0.031	1.25	1.000	1.00	1.00	1.00	1.00	1.00	0.35	161.08	3250.00	0.12	11.17	356.25
+D+0.750L+0.750S+H					1.000	1.00	1.00	1.00	1.00	1.00			0.00	0.00	0.00	0.00
Length = 12.0 ft	1	0.410	0.260	1.15	1.000	1.00	1.00	1.00	1.00	1.00	2.69	1,227.04	2990.00	0.94	85.11	327.75
+D+0.60W+H					1.000	1.00	1.00	1.00	1.00	1.00			0.00	0.00	0.00	0.00
Length = 12.0 ft	1	0.039	0.025	1.60	1.000	1.00	1.00	1.00	1.00	1.00	0.35	161.08	4160.00	0.12	11.17	456.00
+D+0.70E+H					1.000	1.00	1.00	1.00	1.00	1.00			0.00	0.00	0.00	0.00
Length = 12.0 ft	1	0.039	0.025	1.60	1.000	1.00	1.00	1.00	1.00	1.00	0.35	161.08	4160.00	0.12	11.17	456.00
+D+0.750Lr+0.750L+0.450W+H					1.000	1.00	1.00	1.00	1.00	1.00			0.00	0.00	0.00	0.00
Length = 12.0 ft	1	0.039	0.025	1.60	1.000	1.00	1.00	1.00	1.00	1.00	0.35	161.08	4160.00	0.12	11.17	456.00
+D+0.750L+0.750S+0.450W+H					1.000	1.00	1.00	1.00	1.00	1.00			0.00	0.00	0.00	0.00
Length = 12.0 ft	1	0.295	0.187	1.60	1.000	1.00	1.00	1.00	1.00	1.00	2.69	1,227.04	4160.00	0.94	85.11	456.00
+D+0.750L+0.750S+0.5250E+H					1.000	1.00	1.00	1.00	1.00	1.00			0.00	0.00	0.00	0.00
Length = 12.0 ft	1	0.295	0.187	1.60	1.000	1.00	1.00	1.00	1.00	1.00	2.69	1,227.04	4160.00	0.94	85.11	456.00
+0.60D+0.60W+0.60H					1.000	1.00	1.00	1.00	1.00	1.00			0.00	0.00	0.00	0.00
Length = 12.0 ft	1	0.023	0.015	1.60	1.000	1.00	1.00	1.00	1.00	1.00	0.21	96.65	4160.00	0.07	6.70	456.00
+0.60D+0.70E+0.60H					1.000	1.00	1.00	1.00	1.00	1.00			0.00	0.00	0.00	0.00
Length = 12.0 ft	1	0.023	0.015	1.60	1.000	1.00	1.00	1.00	1.00	1.00	0.21	96.65	4160.00	0.07	6.70	456.00

**Overall Maximum Deflections**

Load Combination	Span	Max. "-" Defl	Location in Span	Load Combination	Max. "+" Defl	Location in Span
+D+S+H	1	0.3531	6.263		0.0000	0.000

**Vertical Reactions**

Support notation : Far left is #1

Values in KIPS

Load Combination	Support 1	Support 2
Overall MAXimum	0.752	1.503
Overall MINimum	0.675	1.350
+D+H	0.077	0.153
+D+L+H	0.077	0.153
+D+Lr+H	0.077	0.153
+D+S+H	0.752	1.503
+D+0.750Lr+0.750L+H	0.077	0.153
+D+0.750L+0.750S+H	0.583	1.166
+D+0.60W+H	0.077	0.153
+D+0.70E+H	0.077	0.153
+D+0.750Lr+0.750L+0.450W+H	0.077	0.153
+D+0.750L+0.750S+0.450W+H	0.583	1.166
+D+0.750L+0.750S+0.5250E+H	0.583	1.166
+0.60D+0.60W+0.60H	0.046	0.092
+0.60D+0.70E+0.60H	0.046	0.092
D Only	0.077	0.153
Lr Only		
L Only		
S Only	0.675	1.350
W Only		
E Only		
H Only		



**Wood Beam**

File = V:\\_PROJE-12019\205717-1206BC7-1\CALCUL-105 Beams.ec6 .  
Software copyright ENERCALC, INC. 1983-2018, Build:10.18.11.30 .

Lic. # : KW-06007473

Licensee : SHAWN REEDER

Description : OL Rafters

**CODE REFERENCES**

Calculations per NDS 2015, IBC 2015, CBC 2016, ASCE 7-10  
Load Combination Set : IBC 2015

**Material Properties**

Analysis Method : Allowable Stress Design	Fb +	900.0 psi	E : Modulus of Elasticity
Load Combination IBC 2015	Fb -	900.0 psi	Ebend- xx
	Fc - Prll	1,350.0 psi	Eminbend - xx
Wood Species : DouglasFir-Larch	Fc - Perp	625.0 psi	
Wood Grade : No.2	Fv	180.0 psi	Density
	Ft	575.0 psi	31.210pcf
Beam Bracing : Beam is Fully Braced against lateral-torsional buckling			

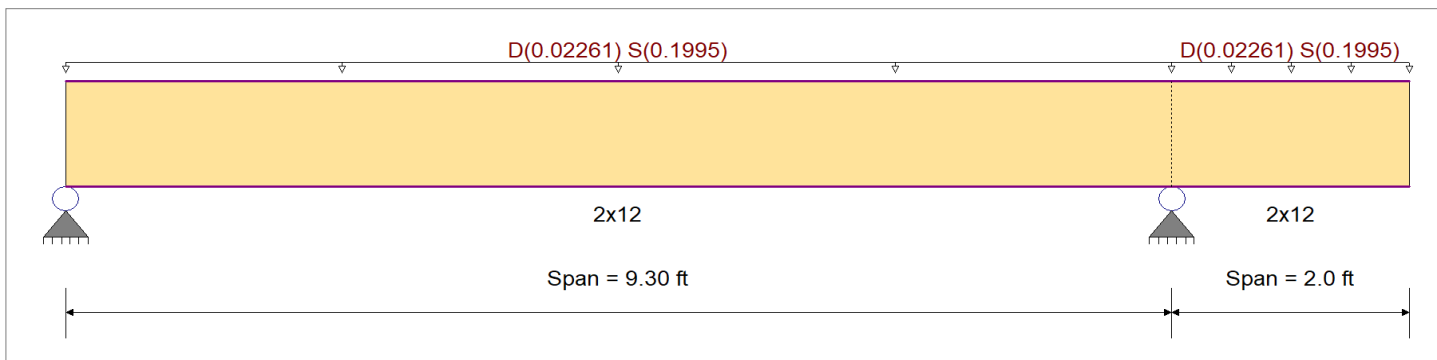

**Applied Loads**

Service loads entered. Load Factors will be applied for calculations.

Load for Span Number 1  
Uniform Load : D = 0.0170, S = 0.150 ksf, Tributary Width = 1.330 ft, (Roof)  
Load for Span Number 2  
Uniform Load : D = 0.0170, S = 0.150 ksf, Tributary Width = 1.330 ft, (Roof)

**DESIGN SUMMARY**

**Design OK**

Maximum Bending Stress Ratio	=	<b>0.800</b>	1	Maximum Shear Stress Ratio	=	<b>0.375</b>	: 1
Section used for this span		<b>2x12</b>		Section used for this span		<b>2x12</b>	
fb : Actual	=	828.41	psi	fv : Actual	=	77.59	psi
FB : Allowable	=	1,035.00	psi	Fv : Allowable	=	207.00	psi
Load Combination		+D+S+H		Load Combination		+D+S+H	
Location of maximum on span	=	4.416	ft	Location of maximum on span	=	8.365	ft
Span # where maximum occurs	=	Span # 1		Span # where maximum occurs	=	Span # 1	
<b>Maximum Deflection</b>							
Max Downward Transient Deflection		0.106	in	Ratio =		1054	>=360
Max Upward Transient Deflection		-0.064	in	Ratio =		752	>=360
Max Downward Total Deflection		0.118	in	Ratio =		947	>=180
Max Upward Total Deflection		-0.071	in	Ratio =		676	>=180

**Maximum Forces & Stresses for Load Combinations**

Load Combination	Segment Length	Span #	Max Stress Ratios								Moment Values			Shear Values						
			M	V	C <sub>d</sub>	C <sub>FV</sub>	C <sub>i</sub>	C <sub>r</sub>	C <sub>m</sub>	C <sub>t</sub>	C <sub>L</sub>	M	fb	F'b	V	fv	Fv			
+D+H	Length = 9.30 ft	1	0.104	0.049	0.90	1.000	1.00	1.00	1.00	1.00	1.00	0.22	84.33	810.00	0.00	0.00	0.00	0.09	7.90	162.00
	Length = 2.0 ft	2	0.021	0.049	0.90	1.000	1.00	1.00	1.00	1.00	1.00	0.05	17.15	810.00	0.02	7.90	162.00			
+D+L+H	Length = 9.30 ft	1	0.094	0.044	1.00	1.000	1.00	1.00	1.00	1.00	1.00	0.22	84.33	900.00	0.00	0.00	0.00	0.09	7.90	180.00
	Length = 2.0 ft	2	0.019	0.044	1.00	1.000	1.00	1.00	1.00	1.00	1.00	0.05	17.15	900.00	0.02	7.90	180.00			
+D+Lr+H	Length = 9.30 ft	1			1.00	1.000	1.00	1.00	1.00	1.00	1.00			0.00	0.00	0.00	0.00	0.00	0.00	0.00
	Length = 9.30 ft	1	0.075	0.035	1.25	1.000	1.00	1.00	1.00	1.00	1.00	0.22	84.33	1125.00	0.00	0.00	0.00	0.09	7.90	225.00



**Wood Beam**

Lic. # : KW-06007473

Licensee : SHAWN REEDER

Description : OL Rafters

Load Combination	Segment Length	Span #	Max Stress Ratios								Moment Values			Shear Values			
			M	V	C <sub>d</sub>	C <sub>F/V</sub>	C <sub>i</sub>	C <sub>r</sub>	C <sub>m</sub>	C <sub>t</sub>	C <sub>L</sub>	M	fb	F'b	V	fv	F'v
	Length = 2.0 ft	2	0.015	0.035	1.25	1.000	1.00	1.00	1.00	1.00	1.00	0.05	17.15	1125.00	0.02	7.90	225.00
+D+S+H						1.000	1.00	1.00	1.00	1.00	1.00			0.00	0.00	0.00	0.00
	Length = 9.30 ft	1	0.800	0.375	1.15	1.000	1.00	1.00	1.00	1.00	1.00	2.18	828.41	1035.00	0.87	77.59	207.00
	Length = 2.0 ft	2	0.163	0.375	1.15	1.000	1.00	1.00	1.00	1.00	1.00	0.44	168.47	1035.00	0.24	77.59	207.00
+D+0.750Lr+0.750L+H						1.000	1.00	1.00	1.00	1.00	1.00			0.00	0.00	0.00	0.00
	Length = 9.30 ft	1	0.075	0.035	1.25	1.000	1.00	1.00	1.00	1.00	1.00	0.22	84.33	1125.00	0.09	7.90	225.00
	Length = 2.0 ft	2	0.015	0.035	1.25	1.000	1.00	1.00	1.00	1.00	1.00	0.05	17.15	1125.00	0.02	7.90	225.00
+D+0.750L+0.750S+H						1.000	1.00	1.00	1.00	1.00	1.00			0.00	0.00	0.00	0.00
	Length = 9.30 ft	1	0.621	0.291	1.15	1.000	1.00	1.00	1.00	1.00	1.00	1.69	642.39	1035.00	0.68	60.17	207.00
	Length = 2.0 ft	2	0.126	0.291	1.15	1.000	1.00	1.00	1.00	1.00	1.00	0.34	130.64	1035.00	0.18	60.17	207.00
+D+0.60W+H						1.000	1.00	1.00	1.00	1.00	1.00			0.00	0.00	0.00	0.00
	Length = 9.30 ft	1	0.059	0.027	1.60	1.000	1.00	1.00	1.00	1.00	1.00	0.22	84.33	1440.00	0.09	7.90	288.00
	Length = 2.0 ft	2	0.012	0.027	1.60	1.000	1.00	1.00	1.00	1.00	1.00	0.05	17.15	1440.00	0.02	7.90	288.00
+D+0.70E+H						1.000	1.00	1.00	1.00	1.00	1.00			0.00	0.00	0.00	0.00
	Length = 9.30 ft	1	0.059	0.027	1.60	1.000	1.00	1.00	1.00	1.00	1.00	0.22	84.33	1440.00	0.09	7.90	288.00
	Length = 2.0 ft	2	0.012	0.027	1.60	1.000	1.00	1.00	1.00	1.00	1.00	0.05	17.15	1440.00	0.02	7.90	288.00
+D+0.750Lr+0.750L+0.450W+H						1.000	1.00	1.00	1.00	1.00	1.00			0.00	0.00	0.00	0.00
	Length = 9.30 ft	1	0.059	0.027	1.60	1.000	1.00	1.00	1.00	1.00	1.00	0.22	84.33	1440.00	0.09	7.90	288.00
	Length = 2.0 ft	2	0.012	0.027	1.60	1.000	1.00	1.00	1.00	1.00	1.00	0.05	17.15	1440.00	0.02	7.90	288.00
+D+0.750L+0.750S+0.450W+H						1.000	1.00	1.00	1.00	1.00	1.00			0.00	0.00	0.00	0.00
	Length = 9.30 ft	1	0.446	0.209	1.60	1.000	1.00	1.00	1.00	1.00	1.00	1.69	642.39	1440.00	0.68	60.17	288.00
	Length = 2.0 ft	2	0.091	0.209	1.60	1.000	1.00	1.00	1.00	1.00	1.00	0.34	130.64	1440.00	0.18	60.17	288.00
+D+0.750L+0.750S+0.5250E+H						1.000	1.00	1.00	1.00	1.00	1.00			0.00	0.00	0.00	0.00
	Length = 9.30 ft	1	0.446	0.209	1.60	1.000	1.00	1.00	1.00	1.00	1.00	1.69	642.39	1440.00	0.68	60.17	288.00
	Length = 2.0 ft	2	0.091	0.209	1.60	1.000	1.00	1.00	1.00	1.00	1.00	0.34	130.64	1440.00	0.18	60.17	288.00
+0.60D+0.60W+0.60H						1.000	1.00	1.00	1.00	1.00	1.00			0.00	0.00	0.00	0.00
	Length = 9.30 ft	1	0.035	0.016	1.60	1.000	1.00	1.00	1.00	1.00	1.00	0.13	50.60	1440.00	0.05	4.74	288.00
	Length = 2.0 ft	2	0.007	0.016	1.60	1.000	1.00	1.00	1.00	1.00	1.00	0.03	10.29	1440.00	0.01	4.74	288.00
+0.60D+0.70E+0.60H						1.000	1.00	1.00	1.00	1.00	1.00			0.00	0.00	0.00	0.00
	Length = 9.30 ft	1	0.035	0.016	1.60	1.000	1.00	1.00	1.00	1.00	1.00	0.13	50.60	1440.00	0.05	4.74	288.00
	Length = 2.0 ft	2	0.007	0.016	1.60	1.000	1.00	1.00	1.00	1.00	1.00	0.03	10.29	1440.00	0.01	4.74	288.00

**Overall Maximum Deflections**

Load Combination	Span	Max. "-" Defl	Location in Span	Load Combination	Max. "+" Defl	Location in Span
+D+S+H	1	0.1178	4.572	+D+S+H	0.0000	0.000
	2	0.0000	4.572		-0.0709	2.000

**Vertical Reactions**

Support notation : Far left is #1

Values in KIPS

Load Combination	Support 1	Support 2	Support 3
Overall MAXimum	0.985	1.525	
Overall MINimum	0.885	1.370	
+D+H	0.100	0.155	
+D+L+H	0.100	0.155	
+D+Lr+H	0.100	0.155	
+D+S+H	0.985	1.525	
+D+0.750Lr+0.750L+H	0.100	0.155	
+D+0.750L+0.750S+H	0.764	1.182	
+D+0.60W+H	0.100	0.155	
+D+0.70E+H	0.100	0.155	
+D+0.750Lr+0.750L+0.450W+H	0.100	0.155	
+D+0.750L+0.750S+0.450W+H	0.764	1.182	
+D+0.750L+0.750S+0.5250E+H	0.764	1.182	
+0.60D+0.60W+0.60H	0.060	0.093	
+0.60D+0.70E+0.60H	0.060	0.093	
D Only	0.100	0.155	
Lr Only			
L Only			
S Only	0.885	1.370	
W Only			
E Only			



Performance Engineers  
1102 N. Franklin Blvd  
Nampa, ID 83687

Project Title:  
Engineer:  
Project ID:  
Project Descr:

## Wood Beam

File = V:\\_PROJE~1\2019\205717~1\206BC7~1\CALCUL~1\05 Beams.ec6 .  
Software copyright ENERCALC, INC. 1983-2018, Build:10.18.11.30 .

Lic. # : KW-06007473

Licensee : SHAWN REEDER

Description : OL Rafters

## Vertical Reactions

Support notation : Far left is #1

Values in KIPS

Load Combination	Support 1	Support 2	Support 3
------------------	-----------	-----------	-----------

H Only



**Wood Beam**

File = V:\\_PROJE~1\2019\205717~1\206BC7~1\CALCUL~1\05 Beams.ec6 .  
Software copyright ENERCALC, INC. 1983-2018, Build:10.18.11.30 .

Lic. # : KW-06007473

Licensee : SHAWN REEDER

Description : Deck

**CODE REFERENCES**

Calculations per NDS 2015, IBC 2015, CBC 2016, ASCE 7-10  
Load Combination Set : IBC 2015

**Material Properties**

Analysis Method : Allowable Stress Design  
Load Combination IBC 2015

Wood Species : DouglasFir-Larch  
Wood Grade : No.2

Beam Bracing : Beam is Fully Braced against lateral-torsional buckling

Fb +	900.0 psi	E : Modulus of Elasticity	
Fb -	900.0 psi	Ebend- xx	1,600.0ksi
Fc - Prll	1,350.0 psi	Eminbend - xx	580.0ksi
Fc - Perp	625.0 psi		
Fv	180.0 psi		
Ft	575.0 psi	Density	31.210pcf

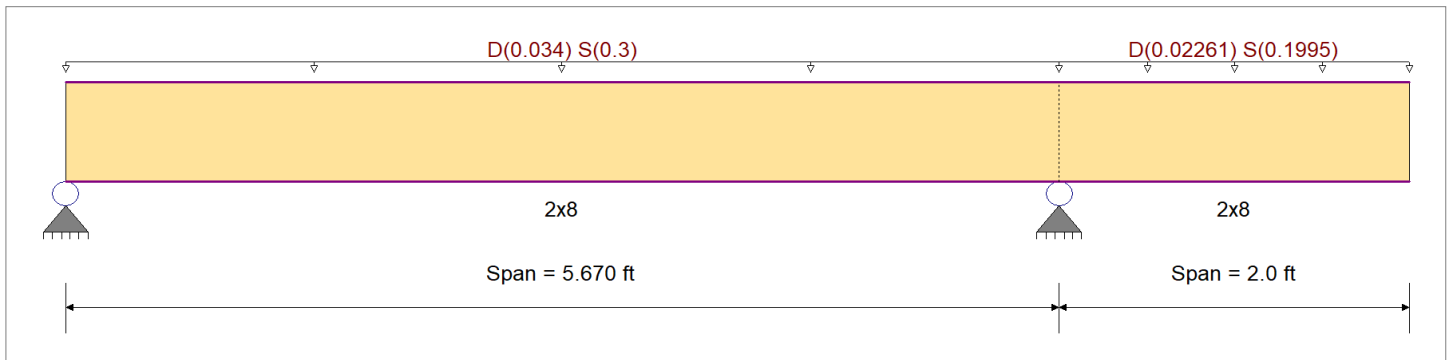

**Applied Loads**

Service loads entered. Load Factors will be applied for calculations.

Load for Span Number 1

Uniform Load : D = 0.0170, S = 0.150 ksf, Tributary Width = 2.0 ft, (Roof)

Load for Span Number 2

Uniform Load : D = 0.0170, S = 0.150 ksf, Tributary Width = 1.330 ft, (Roof)

**DESIGN SUMMARY**

**Design OK**

Maximum Bending Stress Ratio	=	<b>0.830</b>	1	Maximum Shear Stress Ratio	=	<b>0.549</b>	: 1
Section used for this span		<b>2x8</b>		Section used for this span		<b>2x8</b>	
fb : Actual	=	1,031.27	psi	fv : Actual	=	113.69	psi
FB : Allowable	=	1,242.00	psi	Fv : Allowable	=	207.00	psi
Load Combination		+D+S+H		Load Combination		+D+S+H	
Location of maximum on span	=	2.597	ft	Location of maximum on span	=	5.068	ft
Span # where maximum occurs	=	Span # 1		Span # where maximum occurs	=	Span # 1	
<b>Maximum Deflection</b>							
Max Downward Transient Deflection		0.074	in	Ratio =		917	>=360
Max Upward Transient Deflection		-0.060	in	Ratio =		798	>=360
Max Downward Total Deflection		0.083	in	Ratio =		824	>=180
Max Upward Total Deflection		-0.067	in	Ratio =		716	>=180

**Maximum Forces & Stresses for Load Combinations**

Load Combination	Segment Length	Span #	Max Stress Ratios								Moment Values			Shear Values						
			M	V	C <sub>d</sub>	C <sub>FV</sub>	C <sub>i</sub>	C <sub>r</sub>	C <sub>m</sub>	C <sub>t</sub>	C <sub>L</sub>	M	fb	F'b	V	fv	Fv			
+D+H	Length = 5.670 ft	1	0.108	0.071	0.90	1.200	1.00	1.00	1.00	1.00	1.00	0.11	104.98	972.00	0.00	0.00	0.00	0.00	11.57	162.00
	Length = 2.0 ft	2	0.042	0.071	0.90	1.200	1.00	1.00	1.00	1.00	1.00	0.05	41.29	972.00	0.03	11.57	162.00			
+D+L+H	Length = 5.670 ft	1	0.097	0.064	1.00	1.200	1.00	1.00	1.00	1.00	1.00	0.11	104.98	1080.00	0.08	11.57	180.00			
	Length = 2.0 ft	2	0.038	0.064	1.00	1.200	1.00	1.00	1.00	1.00	1.00	0.05	41.29	1080.00	0.03	11.57	180.00			
+D+Lr+H	Length = 5.670 ft	1	0.078	0.051	1.25	1.200	1.00	1.00	1.00	1.00	1.00	0.11	104.98	1350.00	0.08	11.57	225.00			



**Wood Beam**

File = V:\\_PROJE~12019\205717~1206BC7~1\CALCUL~105 Beams.ec6 .  
Software copyright ENERCALC, INC. 1983-2018, Build:10.18.11.30 .

Lic. # : KW-06007473

Licensee : SHAWN REEDER

Description : Deck

Load Combination	Segment Length	Span #	Max Stress Ratios								Moment Values			Shear Values			
			M	V	C <sub>d</sub>	C <sub>F/V</sub>	C <sub>i</sub>	C <sub>r</sub>	C <sub>m</sub>	C <sub>t</sub>	C <sub>L</sub>	M	fb	F'b	V	fv	F'v
	Length = 2.0 ft	2	0.031	0.051	1.25	1.200	1.00	1.00	1.00	1.00	1.00	0.05	41.29	1350.00	0.03	11.57	225.00
+D+S+H						1.200	1.00	1.00	1.00	1.00	1.00			0.00	0.00	0.00	0.00
	Length = 5.670 ft	1	0.830	0.549	1.15	1.200	1.00	1.00	1.00	1.00	1.00	1.13	1,031.27	1242.00	0.82	113.69	207.00
	Length = 2.0 ft	2	0.327	0.549	1.15	1.200	1.00	1.00	1.00	1.00	1.00	0.44	405.66	1242.00	0.31	113.69	207.00
+D+0.750Lr+0.750L+H						1.200	1.00	1.00	1.00	1.00	1.00			0.00	0.00	0.00	0.00
	Length = 5.670 ft	1	0.078	0.051	1.25	1.200	1.00	1.00	1.00	1.00	1.00	0.11	104.98	1350.00	0.08	11.57	225.00
	Length = 2.0 ft	2	0.031	0.051	1.25	1.200	1.00	1.00	1.00	1.00	1.00	0.05	41.29	1350.00	0.03	11.57	225.00
+D+0.750L+0.750S+H						1.200	1.00	1.00	1.00	1.00	1.00			0.00	0.00	0.00	0.00
	Length = 5.670 ft	1	0.644	0.426	1.15	1.200	1.00	1.00	1.00	1.00	1.00	0.88	799.70	1242.00	0.64	88.16	207.00
	Length = 2.0 ft	2	0.253	0.426	1.15	1.200	1.00	1.00	1.00	1.00	1.00	0.34	314.57	1242.00	0.24	88.16	207.00
+D+0.60W+H						1.200	1.00	1.00	1.00	1.00	1.00			0.00	0.00	0.00	0.00
	Length = 5.670 ft	1	0.061	0.040	1.60	1.200	1.00	1.00	1.00	1.00	1.00	0.11	104.98	1728.00	0.08	11.57	288.00
	Length = 2.0 ft	2	0.024	0.040	1.60	1.200	1.00	1.00	1.00	1.00	1.00	0.05	41.29	1728.00	0.03	11.57	288.00
+D+0.70E+H						1.200	1.00	1.00	1.00	1.00	1.00			0.00	0.00	0.00	0.00
	Length = 5.670 ft	1	0.061	0.040	1.60	1.200	1.00	1.00	1.00	1.00	1.00	0.11	104.98	1728.00	0.08	11.57	288.00
	Length = 2.0 ft	2	0.024	0.040	1.60	1.200	1.00	1.00	1.00	1.00	1.00	0.05	41.29	1728.00	0.03	11.57	288.00
+D+0.750Lr+0.750L+0.450W+H						1.200	1.00	1.00	1.00	1.00	1.00			0.00	0.00	0.00	0.00
	Length = 5.670 ft	1	0.061	0.040	1.60	1.200	1.00	1.00	1.00	1.00	1.00	0.11	104.98	1728.00	0.08	11.57	288.00
	Length = 2.0 ft	2	0.024	0.040	1.60	1.200	1.00	1.00	1.00	1.00	1.00	0.05	41.29	1728.00	0.03	11.57	288.00
+D+0.750L+0.750S+0.450W+H						1.200	1.00	1.00	1.00	1.00	1.00			0.00	0.00	0.00	0.00
	Length = 5.670 ft	1	0.463	0.306	1.60	1.200	1.00	1.00	1.00	1.00	1.00	0.88	799.70	1728.00	0.64	88.16	288.00
	Length = 2.0 ft	2	0.182	0.306	1.60	1.200	1.00	1.00	1.00	1.00	1.00	0.34	314.57	1728.00	0.24	88.16	288.00
+D+0.750L+0.750S+0.5250E+H						1.200	1.00	1.00	1.00	1.00	1.00			0.00	0.00	0.00	0.00
	Length = 5.670 ft	1	0.463	0.306	1.60	1.200	1.00	1.00	1.00	1.00	1.00	0.88	799.70	1728.00	0.64	88.16	288.00
	Length = 2.0 ft	2	0.182	0.306	1.60	1.200	1.00	1.00	1.00	1.00	1.00	0.34	314.57	1728.00	0.24	88.16	288.00
+0.60D+0.60W+0.60H						1.200	1.00	1.00	1.00	1.00	1.00			0.00	0.00	0.00	0.00
	Length = 5.670 ft	1	0.036	0.024	1.60	1.200	1.00	1.00	1.00	1.00	1.00	0.07	62.99	1728.00	0.05	6.94	288.00
	Length = 2.0 ft	2	0.014	0.024	1.60	1.200	1.00	1.00	1.00	1.00	1.00	0.03	24.78	1728.00	0.02	6.94	288.00
+0.60D+0.70E+0.60H						1.200	1.00	1.00	1.00	1.00	1.00			0.00	0.00	0.00	0.00
	Length = 5.670 ft	1	0.036	0.024	1.60	1.200	1.00	1.00	1.00	1.00	1.00	0.07	62.99	1728.00	0.05	6.94	288.00
	Length = 2.0 ft	2	0.014	0.024	1.60	1.200	1.00	1.00	1.00	1.00	1.00	0.03	24.78	1728.00	0.02	6.94	288.00

**Overall Maximum Deflections**

Load Combination	Span	Max. "-" Defl	Location in Span	Load Combination	Max. "+" Defl	Location in Span
+D+S+H	1	0.0825	2.756		0.0000	0.000
	2	0.0000	2.756	+D+S+H	-0.0669	2.000

**Vertical Reactions**

Support notation : Far left is #1

Values in KIPS

Load Combination	Support 1	Support 2	Support 3
Overall MAXimum	0.869	1.469	
Overall MINimum	0.780	1.320	
+D+H	0.088	0.150	
+D+L+H	0.088	0.150	
+D+Lr+H	0.088	0.150	
+D+S+H	0.869	1.469	
+D+0.750Lr+0.750L+H	0.088	0.150	
+D+0.750L+0.750S+H	0.674	1.139	
+D+0.60W+H	0.088	0.150	
+D+0.70E+H	0.088	0.150	
+D+0.750Lr+0.750L+0.450W+H	0.088	0.150	
+D+0.750L+0.750S+0.450W+H	0.674	1.139	
+D+0.750L+0.750S+0.5250E+H	0.674	1.139	
+0.60D+0.60W+0.60H	0.053	0.090	
+0.60D+0.70E+0.60H	0.053	0.090	
D Only	0.088	0.150	
Lr Only			
L Only			
S Only	0.780	1.320	
W Only			
E Only			



Performance Engineers  
1102 N. Franklin Blvd  
Nampa, ID 83687

Project Title:  
Engineer:  
Project ID:  
Project Descr:

## Wood Beam

File = V:\\_PROJE~1\2019\205717~1\206BC7~1\CALCUL~1\05 Beams.ec6 .  
Software copyright ENERCALC, INC. 1983-2018, Build:10.18.11.30 .

Lic. # : KW-06007473

Licensee : SHAWN REEDER

Description : Deck

## Vertical Reactions

Support notation : Far left is #1

Values in KIPS

Load Combination	Support 1	Support 2	Support 3
------------------	-----------	-----------	-----------

H Only



**Wood Beam**

File = V:\\_PROJE-12019\205717-1206BC7-1\CALCUL-105 Beams.ec6 .  
Software copyright ENERCALC, INC. 1983-2018, Build:10.18.11.30 .

Lic. # : KW-06007473

Licensee : SHAWN REEDER

Description : Drop Beam

**CODE REFERENCES**

Calculations per NDS 2015, IBC 2015, CBC 2016, ASCE 7-10  
Load Combination Set : IBC 2015

**Material Properties**

Analysis Method : Allowable Stress Design  
Load Combination IBC 2015

Wood Species : DF/DF  
Wood Grade : 24F - V4

Beam Bracing : Beam is Fully Braced against lateral-torsional buckling

Fb +	2,400.0 psi	E : Modulus of Elasticity	
Fb -	1,850.0 psi	Ebend- xx	1,800.0 ksi
Fc - Prll	1,650.0 psi	Eminbend - xx	950.0 ksi
Fc - Perp	650.0 psi	Ebend- yy	1,600.0 ksi
Fv	265.0 psi	Eminbend - yy	850.0 ksi
Ft	1,100.0 psi	Density	31.210 pcf

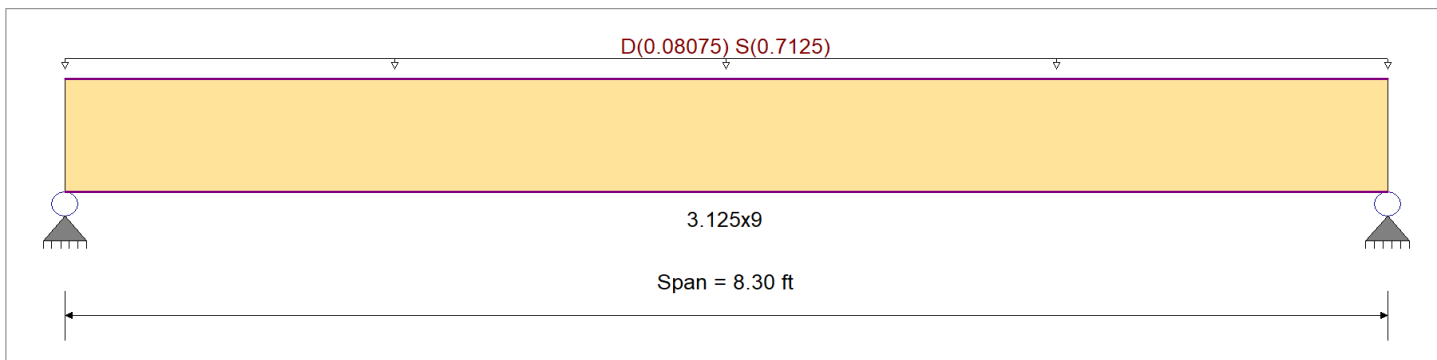

**Applied Loads**

Service loads entered. Load Factors will be applied for calculations.

Uniform Load : D = 0.0170, S = 0.150 ksf, Tributary Width = 4.750 ft, (Roof)

**DESIGN SUMMARY**

**Design OK**

Maximum Bending Stress Ratio =	<b>0.704</b> : 1	Maximum Shear Stress Ratio =	<b>0.475</b> : 1
Section used for this span	<b>3.125x9</b>	Section used for this span	<b>3.125x9</b>
fb : Actual =	1,943.00 psi	fv : Actual =	144.82 psi
FB : Allowable =	2,760.00 psi	Fv : Allowable =	304.75 psi
Load Combination	+D+S+H	Load Combination	+D+S+H
Location of maximum on span	4.150ft	Location of maximum on span	0.000 ft
Span # where maximum occurs	Span # 1	Span # where maximum occurs	Span # 1
<b>Maximum Deflection</b>			
Max Downward Transient Deflection	0.224 in	Ratio =	444 >=360
Max Upward Transient Deflection	0.000 in	Ratio =	0 <360
Max Downward Total Deflection	0.249 in	Ratio =	399 >=180
Max Upward Total Deflection	0.000 in	Ratio =	0 <180

**Maximum Forces & Stresses for Load Combinations**

Load Combination	Segment Length	Span #	Max Stress Ratios								Moment Values			Shear Values									
			M	V	C <sub>d</sub>	C <sub>FV</sub>	C <sub>i</sub>	C <sub>r</sub>	C <sub>m</sub>	C <sub>t</sub>	C <sub>L</sub>	M	fb	F'b	V	fv	F'v						
+D+H	Length = 8.30 ft	1	0.092	0.062	0.90	1.000	1.00	1.00	1.00	1.00	1.00	1.00	1.00	0.70	197.79	2160.00	0.00	0.00	0.00	0.00	0.00	238.50	
+D+L+H	Length = 8.30 ft	1	0.082	0.056	1.00	1.000	1.00	1.00	1.00	1.00	1.00	1.00	1.00	0.70	197.79	2400.00	0.00	0.00	0.00	0.00	0.00	0.00	265.00
+D+Lr+H	Length = 8.30 ft	1	0.066	0.045	1.25	1.000	1.00	1.00	1.00	1.00	1.00	1.00	1.00	0.70	197.79	3000.00	0.00	0.00	0.00	0.00	0.00	0.00	331.25
+D+S+H	Length = 8.30 ft	1	0.704	0.475	1.15	1.000	1.00	1.00	1.00	1.00	1.00	1.00	1.00	6.83	1,943.00	2760.00	0.00	0.00	0.00	2.72	144.82	304.75	
+D+0.750Lr+0.750L+H	Length = 8.30 ft	1	0.066	0.045	1.25	1.000	1.00	1.00	1.00	1.00	1.00	1.00	1.00	0.70	197.79	3000.00	0.00	0.00	0.00	0.00	0.00	0.00	331.25
+D+0.750L+0.750S+H	Length = 8.30 ft	1	0.546	0.368	1.15	1.000	1.00	1.00	1.00	1.00	1.00	1.00	1.00	5.30	1,506.70	2760.00	0.00	0.00	0.00	2.11	112.30	304.75	



Performance Engineers  
1102 N. Franklin Blvd  
Nampa, ID 83687

Project Title:  
Engineer:  
Project ID:  
Project Descr:

**Wood Beam**

File = V:\\_PROJE~1\2019\205717~1\206BC7~1\CALCUL~1\05 Beams.ec6 .  
Software copyright ENERCALC, INC. 1983-2018, Build:10.18.11.30 .

Lic. # : KW-06007473

Licensee : SHAWN REEDER

Description : Drop Beam

Load Combination	Segment Length	Span #	Max Stress Ratios								Moment Values			Shear Values								
			M	V	C <sub>d</sub>	C <sub>F/V</sub>	C <sub>i</sub>	C <sub>r</sub>	C <sub>m</sub>	C <sub>t</sub>	C <sub>L</sub>	M	fb	F'b	V	fv	Fv					
+D+0.60W+H	Length = 8.30 ft	1	0.052	0.035	1.60	1.000	1.00	1.00	1.00	1.00	1.00	1.00	1.00	0.70	197.79	3840.00	0.00	0.00	0.00	0.28	14.74	424.00
+D+0.70E+H	Length = 8.30 ft	1	0.052	0.035	1.60	1.000	1.00	1.00	1.00	1.00	1.00	1.00	1.00	0.70	197.79	3840.00	0.00	0.00	0.00	0.00	0.00	0.00
+D+0.750Lr+0.750L+0.450W+H	Length = 8.30 ft	1	0.052	0.035	1.60	1.000	1.00	1.00	1.00	1.00	1.00	1.00	1.00	0.70	197.79	3840.00	0.00	0.00	0.00	0.28	14.74	424.00
+D+0.750L+0.750S+0.450W+H	Length = 8.30 ft	1	0.392	0.265	1.60	1.000	1.00	1.00	1.00	1.00	1.00	1.00	1.00	5.30	1,506.70	3840.00	0.00	0.00	0.00	2.11	112.30	424.00
+D+0.750L+0.750S+0.5250E+H	Length = 8.30 ft	1	0.392	0.265	1.60	1.000	1.00	1.00	1.00	1.00	1.00	1.00	1.00	5.30	1,506.70	3840.00	0.00	0.00	0.00	0.00	0.00	0.00
+0.60D+0.60W+0.60H	Length = 8.30 ft	1	0.031	0.021	1.60	1.000	1.00	1.00	1.00	1.00	1.00	1.00	1.00	0.42	118.67	3840.00	0.00	0.00	0.00	0.17	8.85	424.00
+0.60D+0.70E+0.60H	Length = 8.30 ft	1	0.031	0.021	1.60	1.000	1.00	1.00	1.00	1.00	1.00	1.00	1.00	0.42	118.67	3840.00	0.00	0.00	0.00	0.17	8.85	424.00

**Overall Maximum Deflections**

Load Combination	Span	Max. "-" Defl	Location in Span	Load Combination	Max. "+" Defl	Location in Span
+D+S+H	1	0.2493	4.180		0.0000	0.000

**Vertical Reactions**

Support notation : Far left is #1

Values in KIPS

Load Combination	Support 1	Support 2
Overall MAXimum	3.292	3.292
Overall MINimum	2.957	2.957
+D+H	0.335	0.335
+D+L+H	0.335	0.335
+D+Lr+H	0.335	0.335
+D+S+H	3.292	3.292
+D+0.750Lr+0.750L+H	0.335	0.335
+D+0.750L+0.750S+H	2.553	2.553
+D+0.60W+H	0.335	0.335
+D+0.70E+H	0.335	0.335
+D+0.750Lr+0.750L+0.450W+H	0.335	0.335
+D+0.750L+0.750S+0.450W+H	2.553	2.553
+D+0.750L+0.750S+0.5250E+H	2.553	2.553
+0.60D+0.60W+0.60H	0.201	0.201
+0.60D+0.70E+0.60H	0.201	0.201
D Only	0.335	0.335
Lr Only		
L Only		
S Only	2.957	2.957
W Only		
E Only		
H Only		



**Wood Beam**

File = V:\\_PROJE~1\2019\205717~1\206BC7~1\CALCUL~1\05 Beams.ec6 .  
Software copyright ENERCALC, INC. 1983-2018, Build:10.18.11.30 .

Lic. # : KW-06007473

Licensee : SHAWN REEDER

Description : Deck Floor

**CODE REFERENCES**

Calculations per NDS 2015, IBC 2015, CBC 2016, ASCE 7-10  
Load Combination Set : IBC 2015

**Material Properties**

Analysis Method : Allowable Stress Design	Fb +	900.0 psi	E : Modulus of Elasticity
Load Combination IBC 2015	Fb -	900.0 psi	Ebend- xx
	Fc - Prll	1,350.0 psi	Eminbend - xx
Wood Species : DouglasFir-Larch	Fc - Perp	625.0 psi	
Wood Grade : No.2	Fv	180.0 psi	Density
	Ft	575.0 psi	31.210pcf
Beam Bracing : Beam is Fully Braced against lateral-torsional buckling			

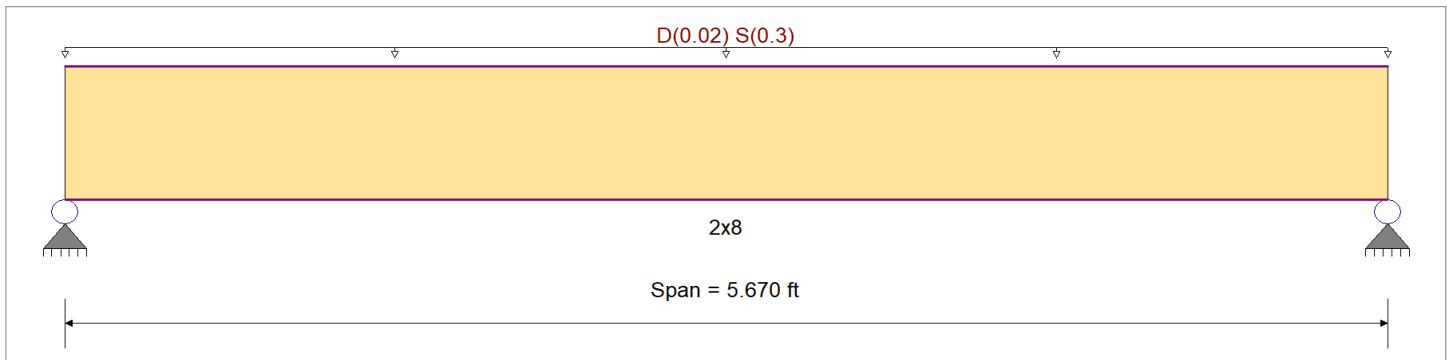

**Applied Loads**

Service loads entered. Load Factors will be applied for calculations.

Uniform Load : D = 0.010, S = 0.150 ksf, Tributary Width = 2.0 ft, (Roof)

**DESIGN SUMMARY**

**Design OK**

Maximum Bending Stress Ratio =	<b>0.946</b>	1	Maximum Shear Stress Ratio =	<b>0.477</b>	: 1
Section used for this span	<b>2x8</b>		Section used for this span	<b>2x8</b>	
fb : Actual =	1,174.33	psi	fv : Actual =	98.64	psi
FB : Allowable =	1,242.00	psi	Fv : Allowable =	207.00	psi
Load Combination =	+D+S+H		Load Combination =	+D+S+H	
Location of maximum on span =	2.835ft		Location of maximum on span =	5.070 ft	
Span # where maximum occurs =	Span # 1		Span # where maximum occurs =	Span # 1	
<b>Maximum Deflection</b>					
Max Downward Transient Deflection	0.092	in	Ratio =	739	>=360
Max Upward Transient Deflection	0.000	in	Ratio =	0	<360
Max Downward Total Deflection	0.098	in	Ratio =	692	>=180
Max Upward Total Deflection	0.000	in	Ratio =	0	<180

**Maximum Forces & Stresses for Load Combinations**

Load Combination	Segment Length	Span #	Max Stress Ratios									Moment Values			Shear Values							
			M	V	C <sub>d</sub>	C <sub>FV</sub>	C <sub>i</sub>	C <sub>r</sub>	C <sub>m</sub>	C <sub>t</sub>	C <sub>L</sub>	M	fb	F'b	V	fv	F'v					
+D+H	Length = 5.670 ft	1	0.076	0.038	0.90	1.200	1.00	1.00	1.00	1.00	1.00	1.00	1.00	0.08	73.40	972.00	0.00	0.00	0.00	0.04	6.17	162.00
+D+L+H	Length = 5.670 ft	1	0.068	0.034	1.00	1.200	1.00	1.00	1.00	1.00	1.00	1.00	1.00	0.08	73.40	1080.00	0.00	0.00	0.00	0.04	6.17	180.00
+D+Lr+H	Length = 5.670 ft	1	0.054	0.027	1.25	1.200	1.00	1.00	1.00	1.00	1.00	1.00	1.00	0.08	73.40	1350.00	0.00	0.00	0.00	0.04	6.17	225.00
+D+S+H	Length = 5.670 ft	1	0.946	0.477	1.15	1.200	1.00	1.00	1.00	1.00	1.00	1.00	1.00	1.29	1,174.33	1242.00	0.00	0.00	0.00	0.72	98.64	207.00
+D+0.750Lr+0.750L+H	Length = 5.670 ft	1	0.054	0.027	1.25	1.200	1.00	1.00	1.00	1.00	1.00	1.00	1.00	0.08	73.40	1350.00	0.00	0.00	0.00	0.04	6.17	225.00
+D+0.750L+0.750S+H	Length = 5.670 ft	1	0.724	0.365	1.15	1.200	1.00	1.00	1.00	1.00	1.00	1.00	1.00	0.98	899.10	1242.00	0.00	0.00	0.00	0.55	75.52	207.00



Performance Engineers  
1102 N. Franklin Blvd  
Nampa, ID 83687

Project Title:  
Engineer:  
Project ID:  
Project Descr:

**Wood Beam**

File = V:\\_PROJE~1\2019\205717~1\206BC7~1\CALCUL~1\05 Beams.ec6 .  
Software copyright ENERCALC, INC. 1983-2018, Build:10.18.11.30 .

Lic. # : KW-06007473

Licensee : SHAWN REEDER

Description : Deck Floor

Load Combination	Segment Length	Span #	Max Stress Ratios								Moment Values			Shear Values					
			M	V	C <sub>d</sub>	C <sub>F/V</sub>	C <sub>i</sub>	C <sub>r</sub>	C <sub>m</sub>	C <sub>t</sub>	C <sub>L</sub>	M	fb	F'b	V	f <sub>v</sub>	F <sub>v</sub>		
+D+0.60W+H	Length = 5.670 ft	1	0.042	0.021	1.60	1.200	1.00	1.00	1.00	1.00	1.00	1.00	1.00	0.08	73.40	1728.00	0.00	0.00	0.00
+D+0.70E+H	Length = 5.670 ft	1	0.042	0.021	1.60	1.200	1.00	1.00	1.00	1.00	1.00	1.00	0.08	73.40	1728.00	0.04	6.17	288.00	
+D+0.750Lr+0.750L+0.450W+H	Length = 5.670 ft	1	0.042	0.021	1.60	1.200	1.00	1.00	1.00	1.00	1.00	1.00	0.08	73.40	1728.00	0.04	6.17	288.00	
+D+0.750L+0.750S+0.450W+H	Length = 5.670 ft	1	0.520	0.262	1.60	1.200	1.00	1.00	1.00	1.00	1.00	1.00	0.98	899.10	1728.00	0.55	75.52	288.00	
+D+0.750L+0.750S+0.5250E+H	Length = 5.670 ft	1	0.520	0.262	1.60	1.200	1.00	1.00	1.00	1.00	1.00	1.00	0.98	899.10	1728.00	0.55	75.52	288.00	
+0.60D+0.60W+0.60H	Length = 5.670 ft	1	0.025	0.013	1.60	1.200	1.00	1.00	1.00	1.00	1.00	1.00	0.05	44.04	1728.00	0.03	3.70	288.00	
+0.60D+0.70E+0.60H	Length = 5.670 ft	1	0.025	0.013	1.60	1.200	1.00	1.00	1.00	1.00	1.00	1.00	0.05	44.04	1728.00	0.03	3.70	288.00	

**Overall Maximum Deflections**

Load Combination	Span	Max. "-" Defl	Location in Span	Load Combination	Max. "+" Defl	Location in Span
+D+S+H	1	0.0982	2.856		0.0000	0.000

**Vertical Reactions**

Support notation : Far left is #1

Values in KIPS

Load Combination	Support 1	Support 2
Overall MAXimum	0.907	0.907
Overall MINimum	0.851	0.851
+D+H	0.057	0.057
+D+L+H	0.057	0.057
+D+Lr+H	0.057	0.057
+D+S+H	0.907	0.907
+D+0.750Lr+0.750L+H	0.057	0.057
+D+0.750L+0.750S+H	0.695	0.695
+D+0.60W+H	0.057	0.057
+D+0.70E+H	0.057	0.057
+D+0.750Lr+0.750L+0.450W+H	0.057	0.057
+D+0.750L+0.750S+0.450W+H	0.695	0.695
+D+0.750L+0.750S+0.5250E+H	0.695	0.695
+0.60D+0.60W+0.60H	0.034	0.034
+0.60D+0.70E+0.60H	0.034	0.034
D Only	0.057	0.057
Lr Only		
L Only		
S Only	0.851	0.851
W Only		
E Only		
H Only		



**Wood Beam**

File = V:\\_PROJE-12019\205717-1206BC7-1\CALCUL-105 Beams.ec6 .  
Software copyright ENERCALC, INC. 1983-2018, Build:10.18.11.30 .

Lic. # : KW-06007473

Licensee : SHAWN REEDER

Description : OL Deck

**CODE REFERENCES**

Calculations per NDS 2015, IBC 2015, CBC 2016, ASCE 7-10  
Load Combination Set : IBC 2015

**Material Properties**

Analysis Method : Allowable Stress Design	Fb +	900.0 psi	E : Modulus of Elasticity
Load Combination IBC 2015	Fb -	900.0 psi	Ebend- xx
	Fc - Prll	1,350.0 psi	Eminbend - xx
Wood Species : DouglasFir-Larch	Fc - Perp	625.0 psi	
Wood Grade : No.2	Fv	180.0 psi	Density
	Ft	575.0 psi	31.210pcf
Beam Bracing : Beam is Fully Braced against lateral-torsional buckling			

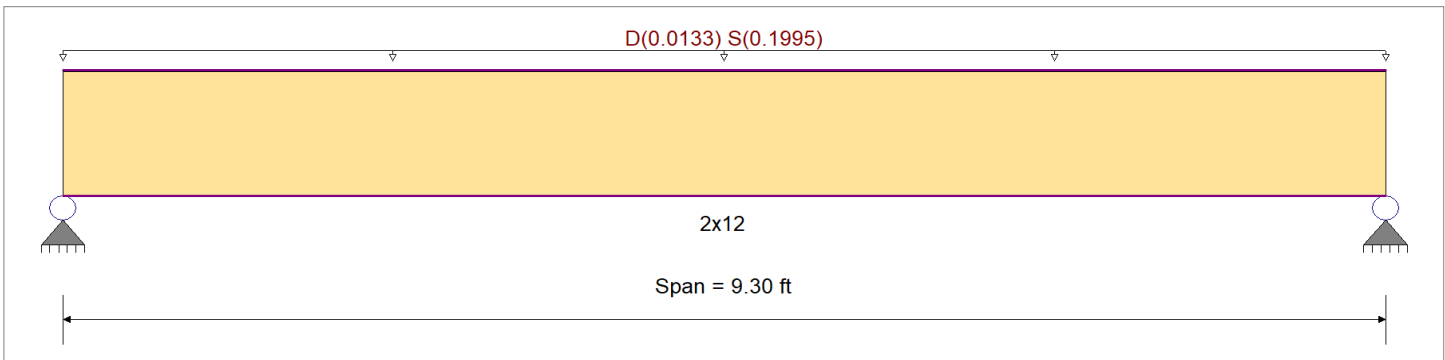

**Applied Loads**

Service loads entered. Load Factors will be applied for calculations.

Uniform Load : D = 0.010, S = 0.150 ksf, Tributary Width = 1.330 ft, (Roof)

**DESIGN SUMMARY**

**Design OK**

Maximum Bending Stress Ratio =	<b>0.843</b> 1	Maximum Shear Stress Ratio =	<b>0.341</b> : 1
Section used for this span	<b>2x12</b>	Section used for this span	<b>2x12</b>
fb : Actual =	872.54 psi	fv : Actual =	70.62 psi
FB : Allowable =	1,035.00 psi	Fv : Allowable =	207.00 psi
Load Combination	+D+S+H	Load Combination	+D+S+H
Location of maximum on span	4.650ft	Location of maximum on span	8.384 ft
Span # where maximum occurs	Span # 1	Span # where maximum occurs	Span # 1
<b>Maximum Deflection</b>			
Max Downward Transient Deflection	0.119 in	Ratio =	940 >=360
Max Upward Transient Deflection	0.000 in	Ratio =	0 <360
Max Downward Total Deflection	0.127 in	Ratio =	882 >=180
Max Upward Total Deflection	0.000 in	Ratio =	0 <180

**Maximum Forces & Stresses for Load Combinations**

Load Combination	Segment Length	Span #	Max Stress Ratios									Moment Values			Shear Values							
			M	V	C <sub>d</sub>	C <sub>FV</sub>	C <sub>i</sub>	C <sub>r</sub>	C <sub>m</sub>	C <sub>t</sub>	C <sub>L</sub>	M	fb	F'b	V	fv	F'v					
+D+H	Length = 9.30 ft	1	0.067	0.027	0.90	1.000	1.00	1.00	1.00	1.00	1.00	1.00	1.00	0.14	54.53	810.00	0.00	0.00	0.00	0.05	4.41	162.00
+D+L+H	Length = 9.30 ft	1	0.061	0.025	1.00	1.000	1.00	1.00	1.00	1.00	1.00	1.00	1.00	0.14	54.53	900.00	0.00	0.00	0.00	0.05	4.41	180.00
+D+Lr+H	Length = 9.30 ft	1	0.048	0.020	1.25	1.000	1.00	1.00	1.00	1.00	1.00	1.00	1.00	0.14	54.53	1125.00	0.00	0.00	0.00	0.05	4.41	225.00
+D+S+H	Length = 9.30 ft	1	0.843	0.341	1.15	1.000	1.00	1.00	1.00	1.00	1.00	1.00	1.00	2.30	872.54	1035.00	0.00	0.00	0.00	0.79	70.62	207.00
+D+0.750Lr+0.750L+H	Length = 9.30 ft	1	0.048	0.020	1.25	1.000	1.00	1.00	1.00	1.00	1.00	1.00	1.00	0.14	54.53	1125.00	0.00	0.00	0.00	0.05	4.41	225.00
+D+0.750L+0.750S+H	Length = 9.30 ft	1	0.645	0.261	1.15	1.000	1.00	1.00	1.00	1.00	1.00	1.00	1.00	1.76	668.04	1035.00	0.00	0.00	0.00	0.61	54.07	207.00



**Wood Beam**

File = V:\\_PROJE~12019\205717~1206BC7~1\CALCUL~105 Beams.ec6 .  
Software copyright ENERCALC, INC. 1983-2018, Build:10.18.11.30 .

Lic. # : KW-06007473

Licensee : SHAWN REEDER

Description : OL Deck

Load Combination	Segment Length	Span #	Max Stress Ratios								Moment Values			Shear Values					
			M	V	C <sub>d</sub>	C <sub>F/V</sub>	C <sub>i</sub>	C <sub>r</sub>	C <sub>m</sub>	C <sub>t</sub>	C <sub>L</sub>	M	fb	F'b	V	f <sub>v</sub>	F <sub>v</sub>		
+D+0.60W+H	Length = 9.30 ft	1	0.038	0.015	1.60	1.000	1.00	1.00	1.00	1.00	1.00	1.00	1.00	0.14	54.53	1440.00	0.00	0.00	0.00
+D+0.70E+H	Length = 9.30 ft	1	0.038	0.015	1.60	1.000	1.00	1.00	1.00	1.00	1.00	1.00	1.00	0.14	54.53	1440.00	0.05	4.41	288.00
+D+0.750Lr+0.750L+0.450W+H	Length = 9.30 ft	1	0.038	0.015	1.60	1.000	1.00	1.00	1.00	1.00	1.00	1.00	1.00	0.14	54.53	1440.00	0.00	0.00	0.00
+D+0.750L+0.750S+0.450W+H	Length = 9.30 ft	1	0.464	0.188	1.60	1.000	1.00	1.00	1.00	1.00	1.00	1.00	1.76	668.04	1440.00	0.00	0.00	0.00	
+D+0.750L+0.750S+0.5250E+H	Length = 9.30 ft	1	0.464	0.188	1.60	1.000	1.00	1.00	1.00	1.00	1.00	1.00	1.76	668.04	1440.00	0.61	54.07	288.00	
+0.60D+0.60W+0.60H	Length = 9.30 ft	1	0.023	0.009	1.60	1.000	1.00	1.00	1.00	1.00	1.00	1.00	0.09	32.72	1440.00	0.00	0.00	0.00	
+0.60D+0.70E+0.60H	Length = 9.30 ft	1	0.023	0.009	1.60	1.000	1.00	1.00	1.00	1.00	1.00	1.00	0.09	32.72	1440.00	0.03	2.65	288.00	

**Overall Maximum Deflections**

Load Combination	Span	Max. "-" Defl	Location in Span	Load Combination	Max. "+" Defl	Location in Span
+D+S+H	1	0.1265	4.684		0.0000	0.000

**Vertical Reactions**

Support notation : Far left is #1

Values in KIPS

Load Combination	Support 1	Support 2
Overall MAXimum	0.990	0.990
Overall MINimum	0.928	0.928
+D+H	0.062	0.062
+D+L+H	0.062	0.062
+D+Lr+H	0.062	0.062
+D+S+H	0.990	0.990
+D+0.750Lr+0.750L+H	0.062	0.062
+D+0.750L+0.750S+H	0.758	0.758
+D+0.60W+H	0.062	0.062
+D+0.70E+H	0.062	0.062
+D+0.750Lr+0.750L+0.450W+H	0.062	0.062
+D+0.750L+0.750S+0.450W+H	0.758	0.758
+D+0.750L+0.750S+0.5250E+H	0.758	0.758
+0.60D+0.60W+0.60H	0.037	0.037
+0.60D+0.70E+0.60H	0.037	0.037
D Only	0.062	0.062
Lr Only		
L Only		
S Only	0.928	0.928
W Only		
E Only		
H Only		



**Wood Beam**

File = V:\\_PROJE-12019\205717-1206BC7-1\CALCUL-1105 Beams.ec6 .  
Software copyright ENERCALC, INC. 1983-2018, Build:10.18.11.30 .

Lic. # : KW-06007473

Licensee : SHAWN REEDER

Description : Drop Beam OL

**CODE REFERENCES**

Calculations per NDS 2015, IBC 2015, CBC 2016, ASCE 7-10  
Load Combination Set : IBC 2015

**Material Properties**

Analysis Method : Allowable Stress Design	Fb +	2400 psi	E : Modulus of Elasticity	
Load Combination IBC 2015	Fb -	1850 psi	Ebend- xx	1800ksi
	Fc - Prll	1650 psi	Eminbend - xx	950ksi
Wood Species : DF/DF	Fc - Perp	650 psi	Ebend- yy	1600ksi
Wood Grade : 24F - V4	Fv	265 psi	Eminbend - yy	850ksi
	Ft	1100 psi	Density	31.21pcf
Beam Bracing : Beam is Fully Braced against lateral-torsional buckling				

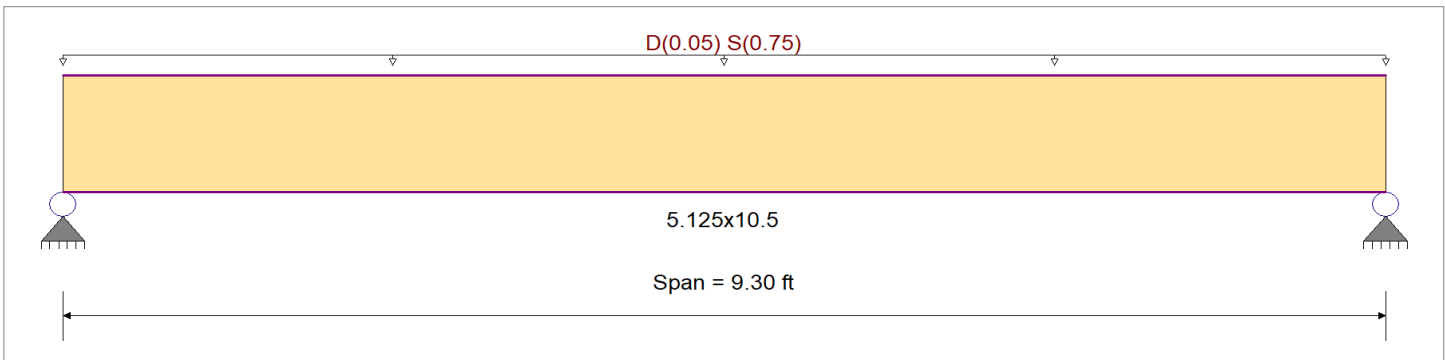

**Applied Loads**

Service loads entered. Load Factors will be applied for calculations.

Uniform Load : D = 0.010, S = 0.150 ksf, Tributary Width = 5.0 ft, (Deck)

**DESIGN SUMMARY**

**Design OK**

Maximum Bending Stress Ratio =	<b>0.399</b> : 1	Maximum Shear Stress Ratio =	<b>0.278</b> : 1
Section used for this span	<b>5.125x10.5</b>	Section used for this span	<b>5.125x10.5</b>
fb : Actual =	1,102.11 psi	fv : Actual =	84.77 psi
FB : Allowable =	2,760.00psi	Fv : Allowable =	304.75 psi
Load Combination	+D+S+H	Load Combination	+D+S+H
Location of maximum on span	4.650ft	Location of maximum on span	8.451 ft
Span # where maximum occurs	Span # 1	Span # where maximum occurs	Span # 1
<b>Maximum Deflection</b>			
Max Downward Transient Deflection	0.143 in	Ratio =	782 >=360
Max Upward Transient Deflection	0.000 in	Ratio =	0 <360
Max Downward Total Deflection	0.152 in	Ratio =	733 >=180
Max Upward Total Deflection	0.000 in	Ratio =	0 <180

**Maximum Forces & Stresses for Load Combinations**

Load Combination	Segment Length	Span #	Max Stress Ratios									Moment Values			Shear Values						
			M	V	C <sub>d</sub>	C <sub>FV</sub>	C <sub>i</sub>	C <sub>r</sub>	C <sub>m</sub>	C <sub>t</sub>	C <sub>L</sub>	M	fb	F'b	V	fv	F'v				
+D+H	Length = 9.30 ft	1	0.032	0.022	0.90	1.000	1.00	1.00	1.00	1.00	1.00	1.00	0.54	68.88	2160.00	0.00	0.00	0.00	0.19	5.30	238.50
+D+L+H	Length = 9.30 ft	1	0.029	0.020	1.00	1.000	1.00	1.00	1.00	1.00	1.00	1.00	0.54	68.88	2400.00	0.00	0.00	0.00	0.19	5.30	265.00
+D+Lr+H	Length = 9.30 ft	1	0.023	0.016	1.25	1.000	1.00	1.00	1.00	1.00	1.00	1.00	0.54	68.88	3000.00	0.00	0.00	0.00	0.19	5.30	331.25
+D+S+H	Length = 9.30 ft	1	0.399	0.278	1.15	1.000	1.00	1.00	1.00	1.00	1.00	1.00	8.65	1,102.11	2760.00	0.00	0.00	0.00	3.04	84.77	304.75
+D+0.750Lr+0.750L+H	Length = 9.30 ft	1	0.023	0.016	1.25	1.000	1.00	1.00	1.00	1.00	1.00	1.00	0.54	68.88	3000.00	0.00	0.00	0.00	0.19	5.30	331.25
+D+0.750L+0.750S+H	Length = 9.30 ft	1	0.306	0.213	1.15	1.000	1.00	1.00	1.00	1.00	1.00	1.00	6.62	843.80	2760.00	0.00	0.00	0.00	2.33	64.90	304.75



Performance Engineers  
1102 N. Franklin Blvd  
Nampa, ID 83687

Project Title:  
Engineer:  
Project ID:  
Project Descr:

**Wood Beam**

File = V:\\_PROJE~1\2019\205717~1\206BC7~1\CALCUL~1\05 Beams.ec6 .  
Software copyright ENERCALC, INC. 1983-2018, Build:10.18.11.30 .

Lic. # : KW-06007473

Licensee : SHAWN REEDER

Description : Drop Beam OL

Load Combination	Segment Length	Span #	Max Stress Ratios								Moment Values			Shear Values					
			M	V	C <sub>d</sub>	C <sub>F/V</sub>	C <sub>i</sub>	C <sub>r</sub>	C <sub>m</sub>	C <sub>t</sub>	C <sub>L</sub>	M	fb	F'b	V	f <sub>v</sub>	F <sub>v</sub>		
+D+0.60W+H	Length = 9.30 ft	1	0.018	0.012	1.60	1.000	1.00	1.00	1.00	1.00	1.00	1.00	1.00	0.54	68.88	3840.00	0.00	0.00	0.00
+D+0.70E+H	Length = 9.30 ft	1	0.018	0.012	1.60	1.000	1.00	1.00	1.00	1.00	1.00	1.00	0.54	68.88	3840.00	0.00	0.00	0.00	
+D+0.750Lr+0.750L+0.450W+H	Length = 9.30 ft	1	0.018	0.012	1.60	1.000	1.00	1.00	1.00	1.00	1.00	1.00	0.54	68.88	3840.00	0.00	0.00	0.00	
+D+0.750L+0.750S+0.450W+H	Length = 9.30 ft	1	0.220	0.153	1.60	1.000	1.00	1.00	1.00	1.00	1.00	1.00	6.62	843.80	3840.00	2.33	64.90	424.00	
+D+0.750L+0.750S+0.5250E+H	Length = 9.30 ft	1	0.220	0.153	1.60	1.000	1.00	1.00	1.00	1.00	1.00	1.00	6.62	843.80	3840.00	2.33	64.90	424.00	
+0.60D+0.60W+0.60H	Length = 9.30 ft	1	0.011	0.007	1.60	1.000	1.00	1.00	1.00	1.00	1.00	1.00	0.32	41.33	3840.00	0.00	0.00	0.00	
+0.60D+0.70E+0.60H	Length = 9.30 ft	1	0.011	0.007	1.60	1.000	1.00	1.00	1.00	1.00	1.00	1.00	0.32	41.33	3840.00	0.00	0.00	0.00	

**Overall Maximum Deflections**

Load Combination	Span	Max. "-" Defl	Location in Span	Load Combination	Max. "+" Defl	Location in Span
+D+S+H	1	0.1522	4.684		0.0000	0.000

**Vertical Reactions**

Support notation : Far left is #1

Values in KIPS

Load Combination	Support 1	Support 2
Overall MAXimum	3.720	3.720
Overall MINimum	3.488	3.488
+D+H	0.233	0.233
+D+L+H	0.233	0.233
+D+Lr+H	0.233	0.233
+D+S+H	3.720	3.720
+D+0.750Lr+0.750L+H	0.233	0.233
+D+0.750L+0.750S+H	2.848	2.848
+D+0.60W+H	0.233	0.233
+D+0.70E+H	0.233	0.233
+D+0.750Lr+0.750L+0.450W+H	0.233	0.233
+D+0.750L+0.750S+0.450W+H	2.848	2.848
+D+0.750L+0.750S+0.5250E+H	2.848	2.848
+0.60D+0.60W+0.60H	0.140	0.140
+0.60D+0.70E+0.60H	0.140	0.140
D Only	0.233	0.233
Lr Only		
L Only		
S Only	3.488	3.488
W Only		
E Only		
H Only		



**Wood Beam**

File = V:\\_PROJE~1\2019\205717~1\206BC7~1\CALCUL~1\05 Beams.ec6 .  
Software copyright ENERCALC, INC. 1983-2018, Build:10.18.11.30 .

Lic. # : KW-06007473

Licensee : SHAWN REEDER

Description : Drop Beam OL 2

**CODE REFERENCES**

Calculations per NDS 2015, IBC 2015, CBC 2016, ASCE 7-10  
Load Combination Set : IBC 2015

**Material Properties**

Analysis Method : Allowable Stress Design  
Load Combination IBC 2015

Wood Species : DF/DF  
Wood Grade : 24F - V4

Beam Bracing : Beam is Fully Braced against lateral-torsional buckling

Fb +	2,400.0 psi	E : Modulus of Elasticity	
Fb -	1,850.0 psi	Ebend- xx	1,800.0ksi
Fc - Prll	1,650.0 psi	Eminbend - xx	950.0ksi
Fc - Perp	650.0 psi	Ebend- yy	1,600.0ksi
Fv	265.0 psi	Eminbend - yy	850.0ksi
Ft	1,100.0 psi	Density	31.210pcf

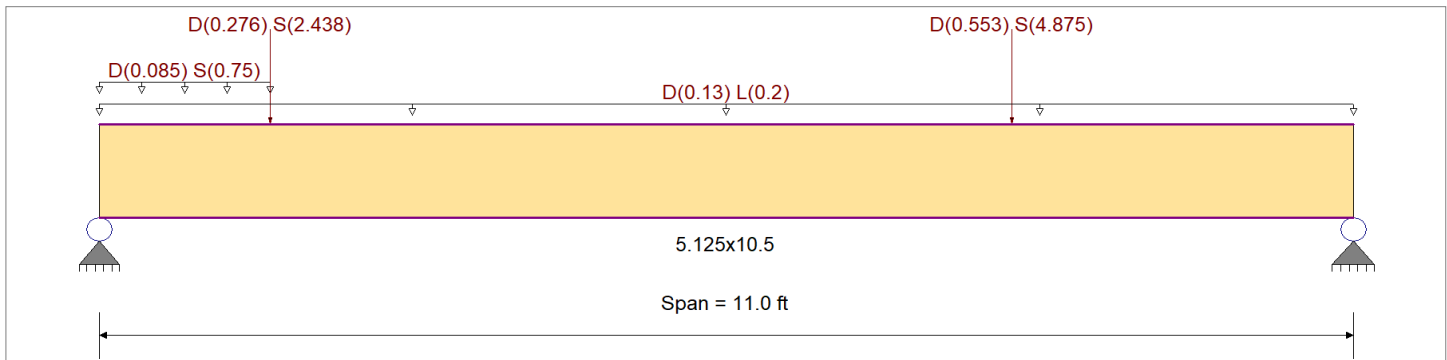

**Applied Loads**

Service loads entered. Load Factors will be applied for calculations.

- Uniform Load : D = 0.0260, L = 0.040 ksf, Tributary Width = 5.0 ft, (Floor)
- Uniform Load : D = 0.0170, S = 0.150 ksf, Extent = 0.0 --> 1.50 ft, Tributary Width = 5.0 ft
- Point Load : D = 0.2760, S = 2.438 k @ 1.50 ft, (Header Load)
- Point Load : D = 0.5530, S = 4.875 k @ 8.0 ft, (Header Load)

**DESIGN SUMMARY**

**Design OK**

Maximum Bending Stress Ratio	=	<b>0.682</b>	1	Maximum Shear Stress Ratio	=	<b>0.458</b>	: 1
Section used for this span		<b>5.125x10.5</b>		Section used for this span		<b>5.125x10.5</b>	
fb : Actual	=	1,881.03psi		fv : Actual	=	139.61 psi	
FB : Allowable	=	2,760.00psi		Fv : Allowable	=	304.75 psi	
Load Combination		+D+S+H		Load Combination		+D+S+H	
Location of maximum on span	=	7.989ft		Location of maximum on span	=	10.157 ft	
Span # where maximum occurs	=	Span # 1		Span # where maximum occurs	=	Span # 1	
<b>Maximum Deflection</b>							
Max Downward Transient Deflection		0.260 in	Ratio =	507	>=	360	
Max Upward Transient Deflection		0.000 in	Ratio =	0	<	360	
Max Downward Total Deflection		0.338 in	Ratio =	390	>=	180	
Max Upward Total Deflection		0.000 in	Ratio =	0	<	180	

**Maximum Forces & Stresses for Load Combinations**

Load Combination	Segment Length	Span #	Max Stress Ratios								Moment Values			Shear Values						
			M	V	C <sub>d</sub>	C <sub>FV</sub>	C <sub>i</sub>	C <sub>r</sub>	C <sub>m</sub>	C <sub>t</sub>	C <sub>L</sub>	M	fb	F'b	V	fv	Fv			
+D+H	Length = 11.0 ft	1	0.182	0.123	0.90	1.000	1.00	1.00	1.00	1.00	1.00	3.09	394.07	2160.00	0.00	0.00	0.00	1.05	29.38	238.50
+D+L+H	Length = 11.0 ft	1	0.323	0.209	1.00	1.000	1.00	1.00	1.00	1.00	1.00	6.09	776.30	2400.00	0.00	0.00	0.00	0.00	0.00	0.00
+D+Lr+H	Length = 11.0 ft	1	0.131	0.089	1.25	1.000	1.00	1.00	1.00	1.00	1.00	3.09	394.07	3000.00	0.00	0.00	0.00	1.05	29.38	331.25
+D+S+H	Length = 11.0 ft	1	0.682	0.458	1.15	1.000	1.00	1.00	1.00	1.00	1.00	14.76	1,881.03	2760.00	0.00	0.00	0.00	5.01	139.61	304.75



Performance Engineers  
1102 N. Franklin Blvd  
Nampa, ID 83687

Project Title:  
Engineer:  
Project ID:  
Project Descr:

**Wood Beam**

File = V:\\_PROJE~1\2019\205717~1\206BC7~1\CALCUL~1\05 Beams.ec6 .  
Software copyright ENERCALC, INC. 1983-2018, Build:10.18.11.30 .

Lic. # : KW-06007473

Licensee : SHAWN REEDER

Description : Drop Beam OL 2

Load Combination	Segment Length	Span #	Max Stress Ratios								Moment Values			Shear Values					
			M	V	C <sub>d</sub>	C <sub>F/V</sub>	C <sub>i</sub>	C <sub>r</sub>	C <sub>m</sub>	C <sub>t</sub>	C <sub>L</sub>	M	fb	F'b	V	f <sub>v</sub>	F <sub>v</sub>		
+D+0.750Lr+0.750L+H	Length = 11.0 ft	1	0.227	0.147	1.25	1.000	1.00	1.00	1.00	1.00	1.00	1.00	1.00	5.34	680.30	3000.00	0.00	0.00	0.00
+D+0.750L+0.750S+H	Length = 11.0 ft	1	0.628	0.432	1.15	1.000	1.00	1.00	1.00	1.00	1.00	1.00	13.60	1,733.30	2760.00	0.00	0.00	0.00	
+D+0.60W+H	Length = 11.0 ft	1	0.103	0.069	1.60	1.000	1.00	1.00	1.00	1.00	1.00	1.00	3.09	394.07	3840.00	0.00	0.00	0.00	
+D+0.70E+H	Length = 11.0 ft	1	0.103	0.069	1.60	1.000	1.00	1.00	1.00	1.00	1.00	1.00	3.09	394.07	3840.00	0.00	0.00	0.00	
+D+0.750Lr+0.750L+0.450W+H	Length = 11.0 ft	1	0.177	0.115	1.60	1.000	1.00	1.00	1.00	1.00	1.00	1.00	5.34	680.30	3840.00	0.00	0.00	0.00	
+D+0.750L+0.750S+0.450W+H	Length = 11.0 ft	1	0.451	0.310	1.60	1.000	1.00	1.00	1.00	1.00	1.00	1.00	13.60	1,733.30	3840.00	0.00	0.00	0.00	
+D+0.750Lr+0.750S+0.5250E+H	Length = 11.0 ft	1	0.451	0.310	1.60	1.000	1.00	1.00	1.00	1.00	1.00	1.00	13.60	1,733.30	3840.00	0.00	0.00	0.00	
+0.60D+0.60W+0.60H	Length = 11.0 ft	1	0.062	0.042	1.60	1.000	1.00	1.00	1.00	1.00	1.00	1.00	1.86	236.44	3840.00	0.00	0.00	0.00	
+0.60D+0.70E+0.60H	Length = 11.0 ft	1	0.062	0.042	1.60	1.000	1.00	1.00	1.00	1.00	1.00	1.00	1.86	236.44	3840.00	0.00	0.00	0.00	

**Overall Maximum Deflections**

Load Combination	Span	Max. "-" Defl	Location in Span	Load Combination	Max. "+" Defl	Location in Span
+D+S+H	1	0.3381	5.781		0.0000	0.000

**Vertical Reactions**

Support notation : Far left is #1

Values in KIPS

Load Combination	Support 1	Support 2
Overall MAXimum	5.706	5.118
Overall MINimum	4.483	3.955
+D+H	1.223	1.164
+D+L+H	2.323	2.264
+D+Lr+H	1.223	1.164
+D+S+H	5.706	5.118
+D+0.750Lr+0.750L+H	2.048	1.989
+D+0.750L+0.750S+H	5.411	4.954
+D+0.60W+H	1.223	1.164
+D+0.70E+H	1.223	1.164
+D+0.750Lr+0.750L+0.450W+H	2.048	1.989
+D+0.750L+0.750S+0.450W+H	5.411	4.954
+D+0.750L+0.750S+0.5250E+H	5.411	4.954
+0.60D+0.60W+0.60H	0.734	0.698
+0.60D+0.70E+0.60H	0.734	0.698
D Only	1.223	1.164
Lr Only		
L Only	1.100	1.100
S Only	4.483	3.955
W Only		
E Only		
H Only		



**Wood Beam**

File = V:\\_PROJE-12019\205717-1206BC7-1\CALCUL-1105 Beams.ec6 .  
Software copyright ENERCALC, INC. 1983-2018, Build:10.18.11.30 .

Lic. # : KW-06007473

Licensee : SHAWN REEDER

Description : Deck Drop Beam

**CODE REFERENCES**

Calculations per NDS 2015, IBC 2015, CBC 2016, ASCE 7-10  
Load Combination Set : IBC 2015

**Material Properties**

Analysis Method : Allowable Stress Design	Fb +	900.0 psi	E : Modulus of Elasticity
Load Combination IBC 2015	Fb -	900.0 psi	Ebend- xx
	Fc - Prll	1,350.0 psi	Eminbend - xx
Wood Species : Douglas Fir - Larch	Fc - Perp	625.0 psi	
Wood Grade : No.2	Fv	180.0 psi	Density
	Ft	575.0 psi	31.210pcf
Beam Bracing : Beam is Fully Braced against lateral-torsional buckling			

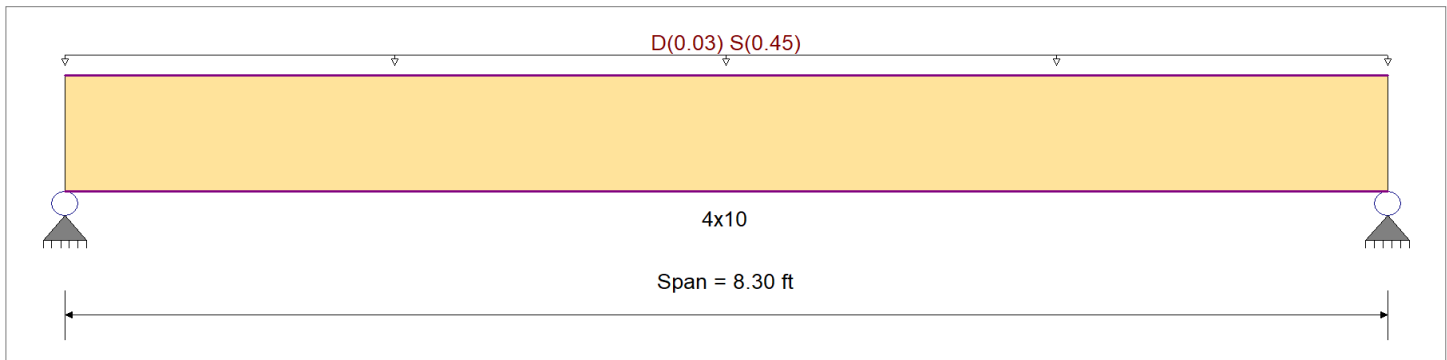

**Applied Loads**

Service loads entered. Load Factors will be applied for calculations.

Uniform Load : D = 0.010, S = 0.150 ksf, Tributary Width = 3.0 ft, (Roof)

**DESIGN SUMMARY**

**Design OK**

Maximum Bending Stress Ratio =	<b>0.800</b> : 1	Maximum Shear Stress Ratio =	<b>0.365</b> : 1
Section used for this span	<b>4x10</b>	Section used for this span	<b>4x10</b>
fb : Actual =	993.78psi	fv : Actual =	75.45 psi
FB : Allowable =	1,242.00psi	Fv : Allowable =	207.00 psi
Load Combination	<b>+D+S+H</b>	Load Combination	<b>+D+S+H</b>
Location of maximum on span	4.150ft	Location of maximum on span	0.000 ft
Span # where maximum occurs	Span # 1	Span # where maximum occurs	Span # 1
<b>Maximum Deflection</b>			
Max Downward Transient Deflection	0.131 in	Ratio =	761 >=360
Max Upward Transient Deflection	0.000 in	Ratio =	0 <360
Max Downward Total Deflection	0.140 in	Ratio =	713 >=180
Max Upward Total Deflection	0.000 in	Ratio =	0 <180

**Maximum Forces & Stresses for Load Combinations**

Load Combination	Segment Length	Span #	Max Stress Ratios								Moment Values			Shear Values						
			M	V	C <sub>d</sub>	C <sub>FV</sub>	C <sub>i</sub>	C <sub>r</sub>	C <sub>m</sub>	C <sub>t</sub>	C <sub>L</sub>	M	fb	F'b	V	fv	F'v			
+D+H	Length = 8.30 ft	1	0.064	0.029	0.90	1.200	1.00	1.00	1.00	1.00	1.00	0.26	62.11	972.00	0.00	0.00	0.00	0.10	4.72	162.00
+D+L+H	Length = 8.30 ft	1	0.058	0.026	1.00	1.200	1.00	1.00	1.00	1.00	1.00	0.26	62.11	1080.00	0.00	0.00	0.00	0.10	4.72	180.00
+D+Lr+H	Length = 8.30 ft	1	0.046	0.021	1.25	1.200	1.00	1.00	1.00	1.00	1.00	0.26	62.11	1350.00	0.00	0.00	0.00	0.10	4.72	225.00
+D+S+H	Length = 8.30 ft	1	0.800	0.365	1.15	1.200	1.00	1.00	1.00	1.00	1.00	4.13	993.78	1242.00	0.00	0.00	0.00	1.63	75.45	207.00
+D+0.750Lr+0.750L+H	Length = 8.30 ft	1	0.046	0.021	1.25	1.200	1.00	1.00	1.00	1.00	1.00	0.26	62.11	1350.00	0.00	0.00	0.00	0.10	4.72	225.00
+D+0.750L+0.750S+H	Length = 8.30 ft	1	0.613	0.279	1.15	1.200	1.00	1.00	1.00	1.00	1.00	3.16	760.86	1242.00	0.00	0.00	0.00	1.25	57.77	207.00



Performance Engineers  
1102 N. Franklin Blvd  
Nampa, ID 83687

Project Title:  
Engineer:  
Project ID:  
Project Descr:

**Wood Beam**

File = V:\\_PROJE~1\2019\205717~1\206BC7~1\CALCUL~1\05 Beams.ec6 .  
Software copyright ENERCALC, INC. 1983-2018, Build:10.18.11.30 .

Lic. # : KW-06007473

Licensee : SHAWN REEDER

Description : Deck Drop Beam

Load Combination	Segment Length	Span #	Max Stress Ratios								Moment Values			Shear Values					
			M	V	C <sub>d</sub>	C <sub>F/V</sub>	C <sub>i</sub>	C <sub>r</sub>	C <sub>m</sub>	C <sub>t</sub>	C <sub>L</sub>	M	fb	F'b	V	fv	Fv		
+D+0.60W+H	Length = 8.30 ft	1	0.036	0.016	1.60	1.200	1.00	1.00	1.00	1.00	1.00	1.00	1.00	0.26	62.11	1728.00	0.00	0.00	0.00
+D+0.70E+H	Length = 8.30 ft	1	0.036	0.016	1.60	1.200	1.00	1.00	1.00	1.00	1.00	1.00	1.00	0.26	62.11	1728.00	0.10	4.72	288.00
+D+0.750Lr+0.750L+0.450W+H	Length = 8.30 ft	1	0.036	0.016	1.60	1.200	1.00	1.00	1.00	1.00	1.00	1.00	1.00	0.26	62.11	1728.00	0.00	0.00	0.00
+D+0.750L+0.750S+0.450W+H	Length = 8.30 ft	1	0.440	0.201	1.60	1.200	1.00	1.00	1.00	1.00	1.00	1.00	1.00	3.16	760.86	1728.00	0.00	0.00	0.00
+D+0.750L+0.750S+0.5250E+H	Length = 8.30 ft	1	0.440	0.201	1.60	1.200	1.00	1.00	1.00	1.00	1.00	1.00	1.00	3.16	760.86	1728.00	1.25	57.77	288.00
+0.60D+0.60W+0.60H	Length = 8.30 ft	1	0.022	0.010	1.60	1.200	1.00	1.00	1.00	1.00	1.00	1.00	1.00	0.16	37.27	1728.00	0.00	0.00	0.00
+0.60D+0.70E+0.60H	Length = 8.30 ft	1	0.022	0.010	1.60	1.200	1.00	1.00	1.00	1.00	1.00	1.00	1.00	0.16	37.27	1728.00	0.06	2.83	288.00

**Overall Maximum Deflections**

Load Combination	Span	Max. "-" Defl	Location in Span	Load Combination	Max. "+" Defl	Location in Span
+D+S+H	1	0.1396	4.180		0.0000	0.000

**Vertical Reactions**

Support notation : Far left is #1

Values in KIPS

Load Combination	Support 1	Support 2
Overall MAXimum	1.992	1.992
Overall MINimum	1.868	1.868
+D+H	0.125	0.125
+D+L+H	0.125	0.125
+D+Lr+H	0.125	0.125
+D+S+H	1.992	1.992
+D+0.750Lr+0.750L+H	0.125	0.125
+D+0.750L+0.750S+H	1.525	1.525
+D+0.60W+H	0.125	0.125
+D+0.70E+H	0.125	0.125
+D+0.750Lr+0.750L+0.450W+H	0.125	0.125
+D+0.750L+0.750S+0.450W+H	1.525	1.525
+D+0.750L+0.750S+0.5250E+H	1.525	1.525
+0.60D+0.60W+0.60H	0.075	0.075
+0.60D+0.70E+0.60H	0.075	0.075
D Only	0.125	0.125
Lr Only		
L Only		
S Only	1.868	1.868
W Only		
E Only		
H Only		



**Wood Beam**

File = V:\\_PROJE~1\2019\205717~1\206BC7~1\CALCUL~1\05 Beams.ec6 .  
Software copyright ENERCALC, INC. 1983-2018, Build:10.18.11.30 .

Lic. # : KW-06007473

Licensee : SHAWN REEDER

Description : Header

**CODE REFERENCES**

Calculations per NDS 2015, IBC 2015, CBC 2016, ASCE 7-10  
Load Combination Set : IBC 2015

**Material Properties**

Analysis Method : Allowable Stress Design  
Load Combination IBC 2015

Wood Species : DF/DF  
Wood Grade : 24F - V4

Beam Bracing : Beam is Fully Braced against lateral-torsional buckling

Fb +	2,400.0 psi	E : Modulus of Elasticity	
Fb -	1,850.0 psi	Ebend- xx	1,800.0 ksi
Fc - Prll	1,650.0 psi	Eminbend - xx	950.0 ksi
Fc - Perp	650.0 psi	Ebend- yy	1,600.0 ksi
Fv	265.0 psi	Eminbend - yy	850.0 ksi
Ft	1,100.0 psi	Density	31.210pcf

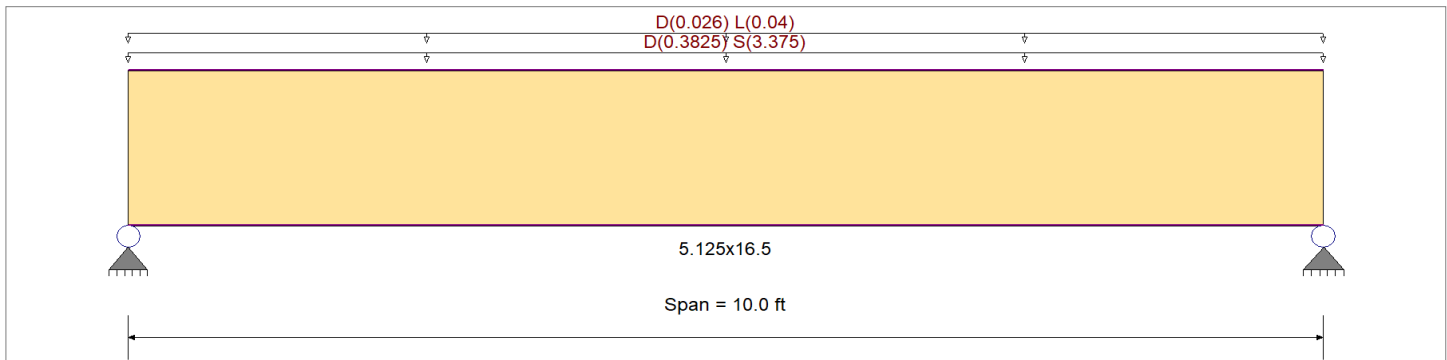

**Applied Loads**

Service loads entered. Load Factors will be applied for calculations.

Uniform Load : D = 0.0170, S = 0.150 ksf, Tributary Width = 22.50 ft, (Roof)  
Uniform Load : D = 0.0260, L = 0.040, Tributary Width = 1.0 ft, (Floor)

**DESIGN SUMMARY**

**Design OK**

Maximum Bending Stress Ratio	=	<b>0.884</b> : 1	Maximum Shear Stress Ratio	=	<b>0.804</b> : 1
Section used for this span	=	<b>5.125x16.5</b>	Section used for this span	=	<b>5.125x16.5</b>
fb : Actual	=	2,440.48 psi	fv : Actual	=	244.94 psi
FB : Allowable	=	2,760.00 psi	Fv : Allowable	=	304.75 psi
Load Combination	=	+D+S+H	Load Combination	=	+D+S+H
Location of maximum on span	=	5.000ft	Location of maximum on span	=	0.000ft
Span # where maximum occurs	=	Span # 1	Span # where maximum occurs	=	Span # 1
<b>Maximum Deflection</b>					
Max Downward Transient Deflection		0.221 in	Ratio =		542 >=360
Max Upward Transient Deflection		0.000 in	Ratio =		0 <360
Max Downward Total Deflection		0.248 in	Ratio =		483 >=180
Max Upward Total Deflection		0.000 in	Ratio =		0 <180

**Maximum Forces & Stresses for Load Combinations**

Load Combination	Segment Length	Span #	Max Stress Ratios										Moment Values			Shear Values					
			M	V	C <sub>d</sub>	C <sub>F/V</sub>	C <sub>i</sub>	C <sub>r</sub>	C <sub>m</sub>	C <sub>t</sub>	C <sub>L</sub>	M	fb	F'b	V	fv	F'v				
+D+H	Length = 10.0 ft	1	0.122	0.111	0.90	1.000	1.00	1.00	1.00	1.00	1.00	1.00	5.11	263.50	2160.00	0.00	0.00	0.00	1.49	26.45	238.50
+D+L+H	Length = 10.0 ft	1	0.121	0.110	1.00	1.000	1.00	1.00	1.00	1.00	1.00	1.00	5.61	289.30	2400.00	0.00	0.00	0.00	0.00	0.00	0.00
+D+Lr+H	Length = 10.0 ft	1	0.088	0.080	1.25	1.000	1.00	1.00	1.00	1.00	1.00	1.00	5.11	263.50	3000.00	0.00	0.00	0.00	1.49	26.45	331.25
+D+S+H	Length = 10.0 ft	1	0.884	0.804	1.15	1.000	1.00	1.00	1.00	1.00	1.00	1.00	47.29	2,440.48	2760.00	0.00	0.00	0.00	13.81	244.94	304.75
+D+0.750Lr+0.750L+H	Length = 10.0 ft	1	0.094	0.086	1.25	1.000	1.00	1.00	1.00	1.00	1.00	1.00	5.48	282.85	3000.00	0.00	0.00	0.00	1.60	28.39	331.25
+D+0.750L+0.750S+H						1.000	1.00	1.00	1.00	1.00	1.00	1.00			0.00	0.00	0.00	0.00	0.00	0.00	



Performance Engineers  
1102 N. Franklin Blvd  
Nampa, ID 83687

Project Title:  
Engineer:  
Project ID:  
Project Descr:

**Wood Beam**

File = V:\\_PROJE~1\2019\205717~1\206BC7~1\CALCUL~1\05 Beams.ec6 .  
Software copyright ENERCALC, INC. 1983-2018, Build:10.18.11.30 .

Lic. # : KW-06007473

Licensee : SHAWN REEDER

Description : Header

Load Combination	Segment Length	Span #	Max Stress Ratios								Moment Values			Shear Values		
			M	V	C <sub>d</sub>	C <sub>F/V</sub>	C <sub>i</sub>	C <sub>r</sub>	C <sub>m</sub>	C <sub>t</sub>	C <sub>L</sub>	M	f <sub>b</sub>	F <sub>b</sub>	V	f <sub>v</sub>
Length = 10.0 ft	1	0.694	0.631	1.15	1.000	1.00	1.00	1.00	1.00	1.00	37.12	1,915.58	2760.00	10.84	192.26	304.75
+D+0.60W+H					1.000	1.00	1.00	1.00	1.00	1.00			0.00	0.00	0.00	0.00
Length = 10.0 ft	1	0.069	0.062	1.60	1.000	1.00	1.00	1.00	1.00	1.00	5.11	263.50	3840.00	1.49	26.45	424.00
+D+0.70E+H					1.000	1.00	1.00	1.00	1.00	1.00			0.00	0.00	0.00	0.00
Length = 10.0 ft	1	0.069	0.062	1.60	1.000	1.00	1.00	1.00	1.00	1.00	5.11	263.50	3840.00	1.49	26.45	424.00
+D+0.750Lr+0.750L+0.450W+H					1.000	1.00	1.00	1.00	1.00	1.00			0.00	0.00	0.00	0.00
Length = 10.0 ft	1	0.074	0.067	1.60	1.000	1.00	1.00	1.00	1.00	1.00	5.48	282.85	3840.00	1.60	28.39	424.00
+D+0.750L+0.750S+0.450W+H					1.000	1.00	1.00	1.00	1.00	1.00			0.00	0.00	0.00	0.00
Length = 10.0 ft	1	0.499	0.453	1.60	1.000	1.00	1.00	1.00	1.00	1.00	37.12	1,915.58	3840.00	10.84	192.26	424.00
+D+0.750L+0.750S+0.5250E+H					1.000	1.00	1.00	1.00	1.00	1.00			0.00	0.00	0.00	0.00
Length = 10.0 ft	1	0.499	0.453	1.60	1.000	1.00	1.00	1.00	1.00	1.00	37.12	1,915.58	3840.00	10.84	192.26	424.00
+0.60D+0.60W+0.60H					1.000	1.00	1.00	1.00	1.00	1.00			0.00	0.00	0.00	0.00
Length = 10.0 ft	1	0.041	0.037	1.60	1.000	1.00	1.00	1.00	1.00	1.00	3.06	158.10	3840.00	0.89	15.87	424.00
+0.60D+0.70E+0.60H					1.000	1.00	1.00	1.00	1.00	1.00			0.00	0.00	0.00	0.00
Length = 10.0 ft	1	0.041	0.037	1.60	1.000	1.00	1.00	1.00	1.00	1.00	3.06	158.10	3840.00	0.89	15.87	424.00

**Overall Maximum Deflections**

Load Combination	Span	Max. "-" Defl	Location in Span	Load Combination	Max. "+" Defl	Location in Span
+D+S+H	1	0.2480	5.036		0.0000	0.000

**Vertical Reactions**

Support notation : Far left is #1

Values in KIPS

Load Combination	Support 1	Support 2
Overall MAXimum	18.918	18.918
Overall MINimum	16.875	16.875
+D+H	2.043	2.043
+D+L+H	2.243	2.243
+D+Lr+H	2.043	2.043
+D+S+H	18.918	18.918
+D+0.750Lr+0.750L+H	2.193	2.193
+D+0.750L+0.750S+H	14.849	14.849
+D+0.60W+H	2.043	2.043
+D+0.70E+H	2.043	2.043
+D+0.750Lr+0.750L+0.450W+H	2.193	2.193
+D+0.750L+0.750S+0.450W+H	14.849	14.849
+D+0.750L+0.750S+0.5250E+H	14.849	14.849
+0.60D+0.60W+0.60H	1.226	1.226
+0.60D+0.70E+0.60H	1.226	1.226
D Only	2.043	2.043
Lr Only		
L Only	0.200	0.200
S Only	16.875	16.875
W Only		
E Only		
H Only		



**Wood Beam**

File = V:\\_PROJE-12019\205717-1206BC7-1\CALCUL-1105 Beams.ec6 .  
Software copyright ENERCALC, INC. 1983-2018, Build:10.18.11.30 .

Lic. # : KW-06007473

Licensee : SHAWN REEDER

Description : Header 3

**CODE REFERENCES**

Calculations per NDS 2015, IBC 2015, CBC 2016, ASCE 7-10  
Load Combination Set : IBC 2015

**Material Properties**

Analysis Method : Allowable Stress Design	Fb +	2,400.0 psi	E : Modulus of Elasticity
Load Combination IBC 2015	Fb -	1,850.0 psi	Ebend- xx
Wood Species : DF/DF	Fc - Prll	1,650.0 psi	Eminbend - xx
Wood Grade : 24F - V4	Fc - Perp	650.0 psi	Ebend- yy
Beam Bracing : Beam is Fully Braced against lateral-torsional buckling	Fv	265.0 psi	Eminbend - yy
	Ft	1,100.0 psi	Density
			31.210pcf

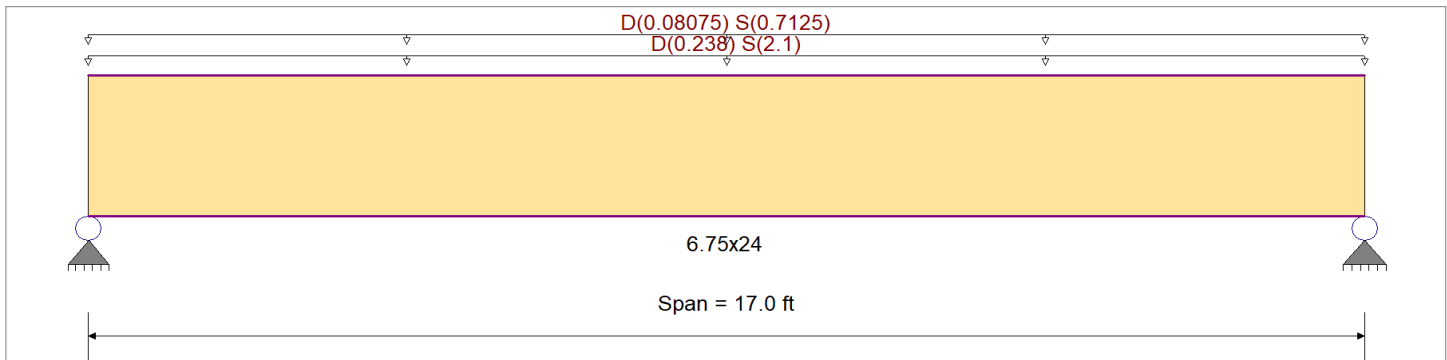

**Applied Loads**

Service loads entered. Load Factors will be applied for calculations.

Uniform Load : D = 0.0170, S = 0.150 ksf, Tributary Width = 14.0 ft, (Roof)  
Uniform Load : D = 0.0170, S = 0.150 ksf, Tributary Width = 4.750 ft, (Roof)

**DESIGN SUMMARY**

**Design OK**

Maximum Bending Stress Ratio =	<b>0.819</b> : 1	Maximum Shear Stress Ratio =	<b>0.620</b> : 1
Section used for this span	<b>6.75x24</b>	Section used for this span	<b>6.75x24</b>
fb : Actual =	2,094.75psi	fv : Actual =	188.88 psi
FB : Allowable =	2,558.72psi	Fv : Allowable =	304.75 psi
Load Combination	+D+S+H	Load Combination	+D+S+H
Location of maximum on span	8.500ft	Location of maximum on span	0.000 ft
Span # where maximum occurs	Span # 1	Span # where maximum occurs	Span # 1
<b>Maximum Deflection</b>			
Max Downward Transient Deflection	0.380 in	Ratio =	537 >=360
Max Upward Transient Deflection	0.000 in	Ratio =	0 <360
Max Downward Total Deflection	0.423 in	Ratio =	482 >=180
Max Upward Total Deflection	0.000 in	Ratio =	0 <180

**Maximum Forces & Stresses for Load Combinations**

Load Combination	Segment Length	Span #	Max Stress Ratios								Moment Values			Shear Values					
			M	V	C <sub>d</sub>	C <sub>F/V</sub>	C <sub>i</sub>	C <sub>r</sub>	C <sub>m</sub>	C <sub>t</sub>	C <sub>L</sub>	M	fb	F'b	V	fv	F'v		
+D+H	Length = 17.0 ft	1	0.106	0.081	0.90	0.927	1.00	1.00	1.00	1.00	1.00	1.00	11.51	213.24	2002.47	0.00	0.00	0.00	238.50
+D+L+H	Length = 17.0 ft	1	0.096	0.073	1.00	0.927	1.00	1.00	1.00	1.00	1.00	1.00	11.51	213.24	2224.97	0.00	0.00	0.00	265.00
+D+Lr+H	Length = 17.0 ft	1	0.077	0.058	1.25	0.927	1.00	1.00	1.00	1.00	1.00	1.00	11.51	213.24	2781.21	0.00	0.00	0.00	331.25
+D+S+H	Length = 17.0 ft	1	0.819	0.620	1.15	0.927	1.00	1.00	1.00	1.00	1.00	1.00	113.12	2,094.75	2558.72	0.00	0.00	0.00	304.75
+D+0.750Lr+0.750L+H	Length = 17.0 ft	1	0.077	0.058	1.25	0.927	1.00	1.00	1.00	1.00	1.00	1.00	11.51	213.24	2781.21	0.00	0.00	0.00	331.25
+D+0.750L+0.750S+H						0.927	1.00	1.00	1.00	1.00	1.00	1.00			0.00	0.00	0.00	0.00	



Performance Engineers  
1102 N. Franklin Blvd  
Nampa, ID 83687

Project Title:  
Engineer:  
Project ID:  
Project Descr:

**Wood Beam**

File = V:\\_PROJE~1\2019\205717~1\206BC7~1\CALCUL~1\05 Beams.ec6 .  
Software copyright ENERCALC, INC. 1983-2018, Build:10.18.11.30 .

Lic. # : KW-06007473

Licensee : SHAWN REEDER

Description : Header 3

Load Combination	Segment Length	Span #	Max Stress Ratios								Moment Values			Shear Values			
			M	V	C <sub>d</sub>	C <sub>F/V</sub>	C <sub>i</sub>	C <sub>r</sub>	C <sub>m</sub>	C <sub>t</sub>	C <sub>L</sub>	M	f <sub>b</sub>	F <sub>b</sub>	V	f <sub>v</sub>	F <sub>v</sub>
Length = 17.0 ft	1	0.635	0.481	1.15	0.927	1.00	1.00	1.00	1.00	1.00	1.00	87.72	1,624.37	2558.72	15.82	146.47	304.75
+D+0.60W+H					0.927	1.00	1.00	1.00	1.00	1.00			0.00	0.00	0.00	0.00	0.00
Length = 17.0 ft	1	0.060	0.045	1.60	0.927	1.00	1.00	1.00	1.00	1.00	1.00	11.51	213.24	3559.95	2.08	19.23	424.00
+D+0.70E+H					0.927	1.00	1.00	1.00	1.00	1.00			0.00	0.00	0.00	0.00	0.00
Length = 17.0 ft	1	0.060	0.045	1.60	0.927	1.00	1.00	1.00	1.00	1.00	1.00	11.51	213.24	3559.95	2.08	19.23	424.00
+D+0.750Lr+0.750L+0.450W+H					0.927	1.00	1.00	1.00	1.00	1.00			0.00	0.00	0.00	0.00	0.00
Length = 17.0 ft	1	0.060	0.045	1.60	0.927	1.00	1.00	1.00	1.00	1.00	1.00	11.51	213.24	3559.95	2.08	19.23	424.00
+D+0.750L+0.750S+0.450W+H					0.927	1.00	1.00	1.00	1.00	1.00			0.00	0.00	0.00	0.00	0.00
Length = 17.0 ft	1	0.456	0.345	1.60	0.927	1.00	1.00	1.00	1.00	1.00	1.00	87.72	1,624.37	3559.95	15.82	146.47	424.00
+D+0.750L+0.750S+0.5250E+H					0.927	1.00	1.00	1.00	1.00	1.00			0.00	0.00	0.00	0.00	0.00
Length = 17.0 ft	1	0.456	0.345	1.60	0.927	1.00	1.00	1.00	1.00	1.00	1.00	87.72	1,624.37	3559.95	15.82	146.47	424.00
+0.60D+0.60W+0.60H					0.927	1.00	1.00	1.00	1.00	1.00			0.00	0.00	0.00	0.00	0.00
Length = 17.0 ft	1	0.036	0.027	1.60	0.927	1.00	1.00	1.00	1.00	1.00	1.00	6.91	127.94	3559.95	1.25	11.54	424.00
+0.60D+0.70E+0.60H					0.927	1.00	1.00	1.00	1.00	1.00			0.00	0.00	0.00	0.00	0.00
Length = 17.0 ft	1	0.036	0.027	1.60	0.927	1.00	1.00	1.00	1.00	1.00	1.00	6.91	127.94	3559.95	1.25	11.54	424.00

**Overall Maximum Deflections**

Load Combination	Span	Max. "-" Defl	Location in Span	Load Combination	Max. "+" Defl	Location in Span
+D+S+H	1	0.4229	8.562		0.0000	0.000

**Vertical Reactions**

Support notation : Far left is #1

Values in KIPS

Load Combination	Support 1	Support 2
Overall MAXimum	26.616	26.616
Overall MINimum	23.906	23.906
+D+H	2.709	2.709
+D+L+H	2.709	2.709
+D+Lr+H	2.709	2.709
+D+S+H	26.616	26.616
+D+0.750Lr+0.750L+H	2.709	2.709
+D+0.750L+0.750S+H	20.639	20.639
+D+0.60W+H	2.709	2.709
+D+0.70E+H	2.709	2.709
+D+0.750Lr+0.750L+0.450W+H	2.709	2.709
+D+0.750L+0.750S+0.450W+H	20.639	20.639
+D+0.750L+0.750S+0.5250E+H	20.639	20.639
+0.60D+0.60W+0.60H	1.626	1.626
+0.60D+0.70E+0.60H	1.626	1.626
D Only	2.709	2.709
Lr Only		
L Only		
S Only	23.906	23.906
W Only		
E Only		
H Only		



**Wood Beam**

File = V:\\_PROJE-12019\205717-1206BC7-1\CALCUL-105 Beams.ec6 .  
Software copyright ENERCALC, INC. 1983-2018, Build:10.18.11.30 .

Lic. # : KW-06007473

Licensee : SHAWN REEDER

Description : Floor Beam

**CODE REFERENCES**

Calculations per NDS 2015, IBC 2015, CBC 2016, ASCE 7-10  
Load Combination Set : IBC 2015

**Material Properties**

Analysis Method : Allowable Stress Design  
Load Combination IBC 2015

Wood Species : DF/DF  
Wood Grade : 24F - V4

Beam Bracing : Beam is Fully Braced against lateral-torsional buckling

Fb +	2,400.0 psi	E : Modulus of Elasticity	
Fb -	1,850.0 psi	Ebend- xx	1,800.0 ksi
Fc - Prll	1,650.0 psi	Eminbend - xx	950.0 ksi
Fc - Perp	650.0 psi	Ebend- yy	1,600.0 ksi
Fv	265.0 psi	Eminbend - yy	850.0 ksi
Ft	1,100.0 psi	Density	31.210 pcf

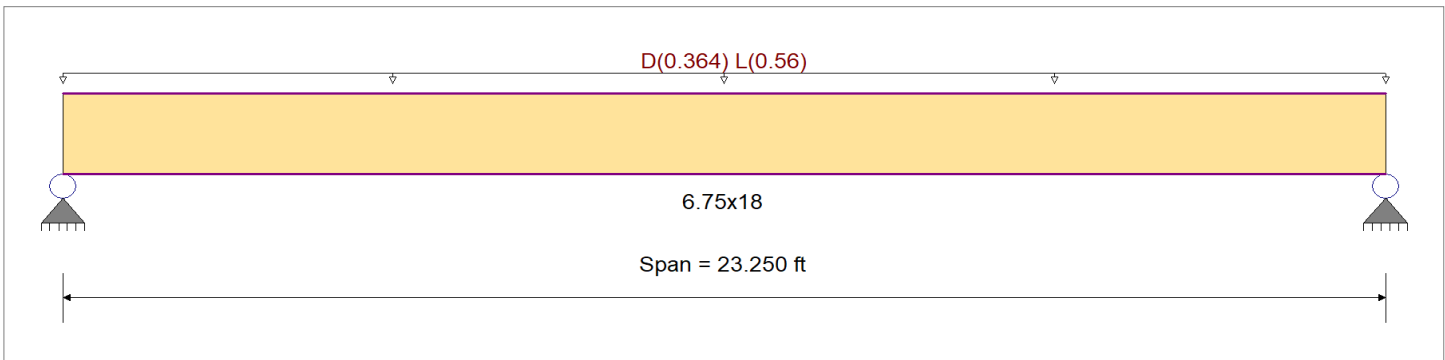

**Applied Loads**

Service loads entered. Load Factors will be applied for calculations.

Uniform Load : D = 0.0260, L = 0.040 ksf, Tributary Width = 14.0 ft, (Floor)

**DESIGN SUMMARY**

**Design OK**

Maximum Bending Stress Ratio	=	<b>0.926</b> : 1	Maximum Shear Stress Ratio	=	<b>0.438</b> : 1
Section used for this span		<b>6.75x18</b>	Section used for this span		<b>6.75x18</b>
fb : Actual	=	2,055.47 psi	fv : Actual	=	116.16 psi
FB : Allowable	=	2,219.32 psi	Fv : Allowable	=	265.00 psi
Load Combination		+D+L+H	Load Combination		+D+L+H
Location of maximum on span	=	11.625 ft	Location of maximum on span	=	21.807 ft
Span # where maximum occurs	=	Span # 1	Span # where maximum occurs	=	Span # 1
<b>Maximum Deflection</b>					
Max Downward Transient Deflection		0.627 in	Ratio =		444 >=360
Max Upward Transient Deflection		0.000 in	Ratio =		0 <360
Max Downward Total Deflection		1.035 in	Ratio =		269 >=180
Max Upward Total Deflection		0.000 in	Ratio =		0 <180

**Maximum Forces & Stresses for Load Combinations**

Load Combination	Segment Length	Span #	Max Stress Ratios									Moment Values			Shear Values			
			M	V	C <sub>d</sub>	C <sub>FV</sub>	C <sub>i</sub>	C <sub>r</sub>	C <sub>m</sub>	C <sub>t</sub>	C <sub>L</sub>	M	fb	F'b	V	fv	F'v	
+D+H	Length = 23.250 ft	1	0.405	0.192	0.90	0.925	1.00	1.00	1.00	1.00	1.00	24.60	809.73	1997.39	0.00	3.71	45.76	238.50
+D+L+H	Length = 23.250 ft	1	0.926	0.438	1.00	0.925	1.00	1.00	1.00	1.00	1.00	62.43	2,055.47	2219.32	0.00	9.41	116.16	265.00
+D+Lr+H	Length = 23.250 ft	1	0.292	0.138	1.25	0.925	1.00	1.00	1.00	1.00	1.00	24.60	809.73	2774.16	0.00	3.71	45.76	331.25
+D+S+H	Length = 23.250 ft	1	0.317	0.150	1.15	0.925	1.00	1.00	1.00	1.00	1.00	24.60	809.73	2552.22	0.00	3.71	45.76	304.75
+D+0.750Lr+0.750L+H	Length = 23.250 ft	1	0.629	0.298	1.25	0.925	1.00	1.00	1.00	1.00	1.00	52.98	1,744.04	2774.16	0.00	7.98	98.56	331.25
+D+0.750L+0.750S+H	Length = 23.250 ft	1	0.683	0.323	1.15	0.925	1.00	1.00	1.00	1.00	1.00	52.98	1,744.04	2552.22	0.00	7.98	98.56	304.75



Performance Engineers  
1102 N. Franklin Blvd  
Nampa, ID 83687

Project Title:  
Engineer:  
Project ID:  
Project Descr:

**Wood Beam**

File = V:\\_PROJE~1\2019\205717~1\206BC7~1\CALCUL~1\05 Beams.ec6 .  
Software copyright ENERCALC, INC. 1983-2018, Build:10.18.11.30 .

Lic. # : KW-06007473

Licensee : SHAWN REEDER

Description : Floor Beam

Load Combination	Segment Length	Span #	Max Stress Ratios								Moment Values			Shear Values								
			M	V	C <sub>d</sub>	C <sub>F/V</sub>	C <sub>i</sub>	C <sub>r</sub>	C <sub>m</sub>	C <sub>t</sub>	C <sub>L</sub>	M	fb	F'b	V	f <sub>v</sub>	F <sub>v</sub>					
+D+0.60W+H	Length = 23.250 ft	1	0.228	0.108	1.60	0.925	1.00	1.00	1.00	1.00	1.00	1.00	1.00	24.60	809.73	3550.92	0.00	0.00	0.00	0.00	0.00	0.00
+D+0.70E+H	Length = 23.250 ft	1	0.228	0.108	1.60	0.925	1.00	1.00	1.00	1.00	1.00	1.00	1.00	24.60	809.73	3550.92	0.00	0.00	0.00	0.00	0.00	0.00
+D+0.750Lr+0.750L+0.450W+H	Length = 23.250 ft	1	0.491	0.232	1.60	0.925	1.00	1.00	1.00	1.00	1.00	1.00	1.00	52.98	1,744.04	3550.92	0.00	0.00	0.00	0.00	0.00	0.00
+D+0.750L+0.750S+0.450W+H	Length = 23.250 ft	1	0.491	0.232	1.60	0.925	1.00	1.00	1.00	1.00	1.00	1.00	1.00	52.98	1,744.04	3550.92	0.00	0.00	0.00	0.00	0.00	0.00
+D+0.750L+0.750S+0.5250E+H	Length = 23.250 ft	1	0.491	0.232	1.60	0.925	1.00	1.00	1.00	1.00	1.00	1.00	1.00	52.98	1,744.04	3550.92	0.00	0.00	0.00	0.00	0.00	0.00
+0.60D+0.60W+0.60H	Length = 23.250 ft	1	0.137	0.065	1.60	0.925	1.00	1.00	1.00	1.00	1.00	1.00	1.00	14.76	485.84	3550.92	0.00	0.00	0.00	0.00	0.00	0.00
+0.60D+0.70E+0.60H	Length = 23.250 ft	1	0.137	0.065	1.60	0.925	1.00	1.00	1.00	1.00	1.00	1.00	1.00	14.76	485.84	3550.92	0.00	0.00	0.00	0.00	0.00	0.00

**Overall Maximum Deflections**

Load Combination	Span	Max. "-" Defl	Location in Span	Load Combination	Max. "+" Defl	Location in Span
+D+L+H	1	1.0348	11.710		0.0000	0.000

**Vertical Reactions**

Support notation : Far left is #1

Values in KIPS

Load Combination	Support 1	Support 2
Overall MAXimum	10.742	10.742
Overall MINimum	6.510	6.510
+D+H	4.232	4.232
+D+L+H	10.742	10.742
+D+Lr+H	4.232	4.232
+D+S+H	4.232	4.232
+D+0.750Lr+0.750L+H	9.114	9.114
+D+0.750L+0.750S+H	9.114	9.114
+D+0.60W+H	4.232	4.232
+D+0.70E+H	4.232	4.232
+D+0.750Lr+0.750L+0.450W+H	9.114	9.114
+D+0.750L+0.750S+0.450W+H	9.114	9.114
+D+0.750L+0.750S+0.5250E+H	9.114	9.114
+0.60D+0.60W+0.60H	2.539	2.539
+0.60D+0.70E+0.60H	2.539	2.539
D Only	4.232	4.232
Lr Only		
L Only	6.510	6.510
S Only		
W Only		
E Only		
H Only		



**Wood Beam**

File = V:\\_PROJE-12019\205717-1206BC7-1\CALCUL-105 Beams.ec6 .  
Software copyright ENERCALC, INC. 1983-2018, Build:10.18.11.30 .

Lic. # : KW-06007473

Licensee : SHAWN REEDER

Description : --None--

**CODE REFERENCES**

Calculations per NDS 2015, IBC 2015, CBC 2016, ASCE 7-10  
Load Combination Set : IBC 2015

**Material Properties**

Analysis Method : Allowable Stress Design	Fb +	2400 psi	E : Modulus of Elasticity	
Load Combination IBC 2015	Fb -	1850 psi	Ebend- xx	1800ksi
	Fc - Prll	1650 psi	Eminbend - xx	950ksi
Wood Species : DF/DF	Fc - Perp	650 psi	Ebend- yy	1600ksi
Wood Grade : 24F - V4	Fv	265 psi	Eminbend - yy	850ksi
	Ft	1100 psi	Density	31.21pcf
Beam Bracing : Beam is Fully Braced against lateral-torsional buckling				

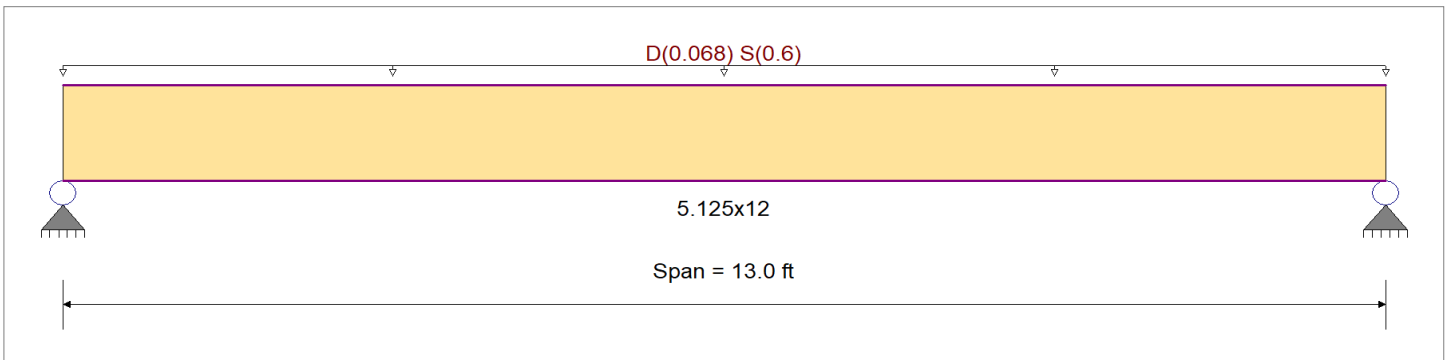

**Applied Loads**

Service loads entered. Load Factors will be applied for calculations.

Uniform Load : D = 0.0170, S = 0.150 ksf, Tributary Width = 4.0 ft, (Roof)

**DESIGN SUMMARY**

**Design OK**

Maximum Bending Stress Ratio =	<b>0.499</b> : 1	Maximum Shear Stress Ratio =	<b>0.294</b> : 1
Section used for this span	<b>5.125x12</b>	Section used for this span	<b>5.125x12</b>
fb : Actual =	1,376.73psi	fv : Actual =	89.67 psi
FB : Allowable =	2,760.00psi	Fv : Allowable =	304.75 psi
Load Combination	+D+S+H	Load Combination	+D+S+H
Location of maximum on span	6.500ft	Location of maximum on span	12.004 ft
Span # where maximum occurs	Span # 1	Span # where maximum occurs	Span # 1
<b>Maximum Deflection</b>			
Max Downward Transient Deflection	0.292 in	Ratio =	534 >=360
Max Upward Transient Deflection	0.000 in	Ratio =	0 <360
Max Downward Total Deflection	0.325 in	Ratio =	479 >=180
Max Upward Total Deflection	0.000 in	Ratio =	0 <180

**Maximum Forces & Stresses for Load Combinations**

Load Combination	Segment Length	Span #	Max Stress Ratios									Moment Values			Shear Values					
			M	V	C <sub>d</sub>	C <sub>FV</sub>	C <sub>i</sub>	C <sub>r</sub>	C <sub>m</sub>	C <sub>t</sub>	C <sub>L</sub>	M	fb	F'b	V	fv	F'v			
+D+H	Length = 13.0 ft	1	0.065	0.038	0.90	1.000	1.00	1.00	1.00	1.00	1.00	1.44	140.15	2160.00	0.00	0.00	0.00	0.00	0.00	238.50
+D+L+H	Length = 13.0 ft	1	0.058	0.034	1.00	1.000	1.00	1.00	1.00	1.00	1.00	1.44	140.15	2400.00	0.00	0.00	0.00	0.00	0.00	0.00
+D+Lr+H	Length = 13.0 ft	1	0.047	0.028	1.25	1.000	1.00	1.00	1.00	1.00	1.00	1.44	140.15	3000.00	0.00	0.00	0.00	0.00	0.00	331.25
+D+S+H	Length = 13.0 ft	1	0.499	0.294	1.15	1.000	1.00	1.00	1.00	1.00	1.00	14.11	1,376.73	2760.00	0.00	0.00	0.00	0.00	0.00	304.75
+D+0.750Lr+0.750L+H	Length = 13.0 ft	1	0.047	0.028	1.25	1.000	1.00	1.00	1.00	1.00	1.00	1.44	140.15	3000.00	0.00	0.00	0.00	0.00	0.00	0.00
+D+0.750L+0.750S+H	Length = 13.0 ft	1	0.387	0.228	1.15	1.000	1.00	1.00	1.00	1.00	1.00	10.94	1,067.59	2760.00	0.00	0.00	0.00	0.00	0.00	0.00



Performance Engineers  
1102 N. Franklin Blvd  
Nampa, ID 83687

Project Title:  
Engineer:  
Project ID:  
Project Descr:

**Wood Beam**

File = V:\\_PROJE~1\2019\205717~1\206BC7~1\CALCUL~1\05 Beams.ec6 .  
Software copyright ENERCALC, INC. 1983-2018, Build:10.18.11.30 .

Lic. # : KW-06007473

Licensee : SHAWN REEDER

Description : --None--

Load Combination	Segment Length	Span #	Max Stress Ratios								Moment Values			Shear Values					
			M	V	C <sub>d</sub>	C <sub>F/V</sub>	C <sub>i</sub>	C <sub>r</sub>	C <sub>m</sub>	C <sub>t</sub>	C <sub>L</sub>	M	fb	F'b	V	f <sub>v</sub>	F <sub>v</sub>		
+D+0.60W+H	Length = 13.0 ft	1	0.036	0.022	1.60	1.000	1.00	1.00	1.00	1.00	1.00	1.00	1.00	1.44	140.15	3840.00	0.00	0.00	0.00
+D+0.70E+H	Length = 13.0 ft	1	0.036	0.022	1.60	1.000	1.00	1.00	1.00	1.00	1.00	1.00	1.44	140.15	3840.00	0.37	9.13	424.00	
+D+0.750Lr+0.750L+0.450W+H	Length = 13.0 ft	1	0.036	0.022	1.60	1.000	1.00	1.00	1.00	1.00	1.00	1.00	1.44	140.15	3840.00	0.37	9.13	424.00	
+D+0.750L+0.750S+0.450W+H	Length = 13.0 ft	1	0.278	0.164	1.60	1.000	1.00	1.00	1.00	1.00	1.00	1.00	10.94	1,067.59	3840.00	2.85	69.53	424.00	
+D+0.750L+0.750S+0.5250E+H	Length = 13.0 ft	1	0.278	0.164	1.60	1.000	1.00	1.00	1.00	1.00	1.00	1.00	10.94	1,067.59	3840.00	2.85	69.53	424.00	
+0.60D+0.60W+0.60H	Length = 13.0 ft	1	0.022	0.013	1.60	1.000	1.00	1.00	1.00	1.00	1.00	1.00	0.86	84.09	3840.00	0.22	5.48	424.00	
+0.60D+0.70E+0.60H	Length = 13.0 ft	1	0.022	0.013	1.60	1.000	1.00	1.00	1.00	1.00	1.00	1.00	0.86	84.09	3840.00	0.22	5.48	424.00	

**Overall Maximum Deflections**

Load Combination	Span	Max. "-" Defl	Location in Span	Load Combination	Max. "+" Defl	Location in Span
+D+S+H	1	0.3250	6.547		0.0000	0.000

**Vertical Reactions**

Support notation : Far left is #1

Values in KIPS

Load Combination	Support 1	Support 2
Overall MAXimum	4.342	4.342
Overall MINimum	3.900	3.900
+D+H	0.442	0.442
+D+L+H	0.442	0.442
+D+Lr+H	0.442	0.442
+D+S+H	4.342	4.342
+D+0.750Lr+0.750L+H	0.442	0.442
+D+0.750L+0.750S+H	3.367	3.367
+D+0.60W+H	0.442	0.442
+D+0.70E+H	0.442	0.442
+D+0.750Lr+0.750L+0.450W+H	0.442	0.442
+D+0.750L+0.750S+0.450W+H	3.367	3.367
+D+0.750L+0.750S+0.5250E+H	3.367	3.367
+0.60D+0.60W+0.60H	0.265	0.265
+0.60D+0.70E+0.60H	0.265	0.265
D Only	0.442	0.442
Lr Only		
L Only		
S Only	3.900	3.900
W Only		
E Only		
H Only		

## Stud Wall - Combined Bending and Compression



Project Name: 19-07 Romine  
 Job Number: 2019-07873  
 Location: Valley County, Idaho  
 Engineer: SB  
 Checker: KJ

This spreadsheet is used for designing a stud wall according to the NDS. Inputs are in **Red** and outputs are in **BOLDF**.

### Overall Loading

Roof	Overhang	Span	Dead Load	Live / Snow Load	Total Load
	<b>2</b>	<b>45</b>	<b>417</b>	<b>3675</b>	
Floor		Span	Dead Load	Dead Load	
		<b>14</b>	<b>182</b>	<b>280</b>	
Wall	Plate Height	Header Height	Dead Load		
	<b>9</b>	<b>6.67</b>	<b>28</b>		
Total Load			<b>626 plf</b>	<b>3,955 plf</b>	<b>4,581 plf</b>

Description:	2 ft Opening	3 ft Opening	4 ft Opening	5 ft Opening	
<b>Header Callout</b>	(2)2x12 DF-L No. 2	(2) 9-1/2" LVL 2.0E	(2) 11-7/8" LVL 2.0E	(2) 16" LVL 2.0E	
<b>Trimmers</b>	(2)2x DF #2	(3)2x DF #2	(3)2x DF #2	(4)2x DF #2	
<b>Wood Design</b>					
Species	DF-L	LVL	LVL	LVL	
Grade	No. 2	2.0E	2.0E	2.0E	
Width	3.00 in	3.50 in	3.50 in	3.50 in	
Depth	11.25 in	9.50 in	11.88 in	16.00 in	
<b>Load</b>					
lu	2.0 ft	3.0 ft	4.0 ft	5.0 ft	
le	4.1 ft	6.2 ft	8.2 ft	10.3 ft	
<b>Adjustment Factors</b>					
Cd	1.15	1.15	1.15	1.15	
CF	1.2	1.2	1	1	
<b>Material Properties</b>					
Fb	900 psi	2,900 psi	2,900 psi	2,900 psi	
Fv	190 psi	290 psi	290 psi	290 psi	
E	1,600,000 psi	2,000,000 psi	2,000,000 psi	2,000,000 psi	
Emin	580,000 psi	1,016,535 psi	1,016,535 psi	1,016,535 psi	
<b>Calculated Prop.</b>					
A	33.75 in <sup>2</sup>	33.25 in <sup>2</sup>	41.56 in <sup>2</sup>	56.00 in <sup>2</sup>	
I	355.96 in <sup>4</sup>	250.07 in <sup>4</sup>	488.41 in <sup>4</sup>	1,194.67 in <sup>4</sup>	
S	63.28 in <sup>3</sup>	52.65 in <sup>3</sup>	82.26 in <sup>3</sup>	149.33 in <sup>3</sup>	
RB	7.86	7.58	9.79	12.71	
Emin'	580,000 psi	1,016,535 psi	1,016,535 psi	1,016,535 psi	
FbE	11,262 psi	21,210 psi	12,726 psi	7,556 psi	
Fb*	1,035 psi	3,669 psi	3,335 psi	3,335 psi	
CL	1	1	1	1	
<b>Shear and Moment</b>					
M	27,489 lb-in	61,850 lb-in	109,955 lb-in	171,805 lb-in	
V	4,581 lbs	6,872 lbs	9,163 lbs	11,454 lbs	
<b>Stress</b>					
fb	434 psi	1,175 psi	1,337 psi	1,150 psi	
Fb'	1,030 psi	3,631 psi	3,278 psi	3,216 psi	
fb/Fb'	0.42	0.32	0.41	0.36	
fv	204 psi	310 psi	331 psi	307 psi	
Fv'	219 psi	334 psi	334 psi	334 psi	
fv/Fv'	0.93	0.93	0.99	0.92	
Max Ratio	0.93	0.93	0.99	0.92	
	Pass	Pass	Pass	Pass	
<b>Deflection</b>					
Δu	0.00 in	0.02 in	0.03 in	0.03 in	
	L/8,287	L/2,156	L/1,777	L/2,225	
Δu	0.00 in	0.01 in	0.02 in	0.02 in	
	L/9,600	L/2,498	L/2,058	L/2,578	
	Pass	Pass	Pass	Pass	

## Stud Wall - Combined Bending and Compression



Project Name: 19-07 Romine  
 Job Number: 2019-07873  
 Location: Valley County, Idaho  
 Engineer: SB  
 Checker: KJ

This spreadsheet is used for designing a stud wall according to the NDS. Inputs are in **Red** and outputs are in **BOLDF**.

### Overall Loading

Roof	Overhang	Span	Dead Load	Live / Snow Load	Total Load
	2	28.5	276	2438	
Floor		Span	Dead Load	Dead Load	
		28.5	371	570	
Wall	Plate Height	Header Height	Dead Load		
	9	6.67	28		
Total Load			<b>675 plf</b>	<b>3,008 plf</b>	<b>3,682 plf</b>

Description:	3 ft Opening	4 ft Opening	5 ft Opening	6 ft Opening	
Header Callout	(2) 9-1/2" LVL 2.0E	(2) 9-1/2" LVL 2.0E	(2) 11-7/8" LVL 2.0E	(2) 16" LVL 2.0E	
Trimmers	(2)2x DF #2	(3)2x DF #2	(3)2x DF #2	(4)2x DF #2	
Wood Design					
Species	LVL	LVL	LVL	LVL	
Grade	2.0E	2.0E	2.0E	2.0E	
Width	3.50 in	3.50 in	3.50 in	3.50 in	
Depth	9.50 in	9.50 in	11.88 in	16.00 in	
Load					
lu	3.0 ft	4.0 ft	5.0 ft	6.0 ft	
le	6.2 ft	8.2 ft	10.3 ft	12.4 ft	
Adjustment Factors					
Cd	1.15	1.15	1.15	1.15	
CF	1.2	1.2	1	1	
Material Properties					
Fb	2,900 psi	2,900 psi	2,900 psi	2,900 psi	
Fv	290 psi	290 psi	290 psi	290 psi	
E	2,000,000 psi	2,000,000 psi	2,000,000 psi	2,000,000 psi	
Emin	1,016,535 psi	1,016,535 psi	1,016,535 psi	1,016,535 psi	
Calculated Prop.					
A	33.25 in^2	33.25 in^2	41.56 in^2	56.00 in^2	
I	250.07 in^4	250.07 in^4	488.41 in^4	1,194.67 in^4	
S	52.65 in^3	52.65 in^3	82.26 in^3	149.33 in^3	
RB	7.58	8.76	10.95	13.92	
Emin'	1,016,535 psi	1,016,535 psi	1,016,535 psi	1,016,535 psi	
FbE	21,210 psi	15,908 psi	10,181 psi	6,297 psi	
Fb*	3,669 psi	3,669 psi	3,335 psi	3,335 psi	
CL	1	1	1	1	
Shear and Moment					
M	49,710 lb-in	88,373 lb-in	138,083 lb-in	198,839 lb-in	
V	5,523 lbs	7,364 lbs	9,206 lbs	11,047 lbs	
Stress					
fb	944 psi	1,679 psi	1,679 psi	1,332 psi	
Fb'	3,631 psi	3,615 psi	3,258 psi	3,174 psi	
fb/Fb'	0.26	0.46	0.52	0.42	
fv	249 psi	332 psi	332 psi	296 psi	
Fv'	334 psi	334 psi	334 psi	334 psi	
fv/Fv'	0.75	1.00	1.00	0.89	
Max Ratio	0.75	1.00	1.00	0.89	
	Pass	Pass	Pass	Pass	
Deflection					
Δu	0.01 in	0.04 in	0.05 in	0.04 in	
	L/2,683	L/1,132	L/1,132	L/1,602	
Δu	0.01 in	0.03 in	0.04 in	0.04 in	
	L/3,285	L/1,386	L/1,386	L/1,962	
	Pass	Pass	Pass	Pass	

## Stud Wall - Combined Bending and Compression



Project Name: 19-07 Romine  
 Job Number: 2019-07873  
 Location: Valley County, Idaho  
 Engineer: SB  
 Checker: KJ

This spreadsheet is used for designing a stud wall according to the NDS. Inputs are in **Red** and outputs are in **BOLDFACE**.

### Overall Loading

Roof	Overhang	Span	Dead Load	Live / Snow Load	Total Load
	2	18	187	1650	
Floor		Span	Dead Load	Dead Load	
		0	0	0	
Wall	Plate Height	Header Height	Dead Load		
	9	6.67	28		
Total Load			215 plf	1,650 plf	1,865 plf

Description:	3 ft Opening	4 ft Opening	5 ft Opening	6 ft Opening	7 ft Opening	8 ft Opening	9 ft Opening	10 ft Opening	12 ft Opening
<b>Header Callout</b>	(2)2x8 DF-L No. 2	(2)2x10 DF-L No. 2	(2) 9-1/2" LVL 2.0E	(2) 9-1/2" LVL 2.0E	(2) 9-1/2" LVL 2.0E	(2) 11-7/8" LVL 2.0E	(2) 11-7/8" LVL 2.0E	(2) 14" LVL 2.0E	(2) 16" LVL 2.0E
<b>Trimmers</b>	(1)2x DF #2	(2)2x DF #2	(2)2x DF #2	(2)2x DF #2	(2)2x DF #2	(3)2x DF #2	(3)2x DF #2	(3)2x DF #2	(4)2x DF #2
<b>Wood Design</b>									
Species	DF-L	DF-L	LVL	LVL	LVL	LVL	LVL	LVL	LVL
Grade	No. 2	No. 2	2.0E	2.0E	2.0E	2.0E	2.0E	2.0E	2.0E
Width	3.00 in	3.00 in	3.50 in	3.50 in	3.50 in	3.50 in	3.50 in	3.50 in	3.50 in
Depth	7.25 in	9.25 in	9.50 in	9.50 in	9.50 in	11.88 in	11.88 in	14.00 in	16.00 in
<b>Load</b>									
ulu	3.0 ft	4.0 ft	5.0 ft	6.0 ft	7.0 ft	8.0 ft	9.0 ft	10.0 ft	12.0 ft
le	6.2 ft	8.2 ft	10.3 ft	12.2 ft	13.8 ft	16.0 ft	17.6 ft	19.8 ft	23.6 ft
<b>Adjustment Factors</b>									
Cd	1.15	1.15	1.15	1.15	1.15	1.15	1.15	1.15	1.15
CF	1.2	1.2	1.2	1.1	1.1	1	1	1	1
<b>Material Properties</b>									
Fb	900 psi	900 psi	2,900 psi	2,900 psi	2,900 psi	2,900 psi	2,900 psi	2,900 psi	2,900 psi
Fv	190 psi	190 psi	290 psi	290 psi	290 psi	290 psi	290 psi	290 psi	290 psi
E	1,600,000 psi	1,600,000 psi	2,000,000 psi	2,000,000 psi	2,000,000 psi	2,000,000 psi	2,000,000 psi	2,000,000 psi	2,000,000 psi
Emin	580,000 psi	580,000 psi	1,016,535 psi	1,016,535 psi	1,016,535 psi	1,016,535 psi	1,016,535 psi	1,016,535 psi	1,016,535 psi
<b>Calculated Prop.</b>									
A	21.75 in <sup>2</sup>	27.75 in <sup>2</sup>	33.25 in <sup>2</sup>	33.25 in <sup>2</sup>	33.25 in <sup>2</sup>	41.56 in <sup>2</sup>	41.56 in <sup>2</sup>	49.00 in <sup>2</sup>	56.00 in <sup>2</sup>
I	95.27 in <sup>4</sup>	197.86 in <sup>4</sup>	250.07 in <sup>4</sup>	250.07 in <sup>4</sup>	250.07 in <sup>4</sup>	488.41 in <sup>4</sup>	488.41 in <sup>4</sup>	800.33 in <sup>4</sup>	1,194.67 in <sup>4</sup>
S	26.28 in <sup>3</sup>	42.78 in <sup>3</sup>	52.65 in <sup>3</sup>	52.65 in <sup>3</sup>	52.65 in <sup>3</sup>	82.26 in <sup>3</sup>	82.26 in <sup>3</sup>	114.33 in <sup>3</sup>	149.33 in <sup>3</sup>
RB	7.73	10.08	9.79	10.64	11.33	13.65	14.32	16.48	19.22
Emin'	580,000 psi	580,000 psi	1,016,535 psi	1,016,535 psi	1,016,535 psi	1,016,535 psi	1,016,535 psi	1,016,535 psi	1,016,535 psi
FbE	11,650 psi	6,849 psi	12,726 psi	10,784 psi	9,509 psi	6,550 psi	5,945 psi	4,492 psi	3,303 psi
Fb*	1,242 psi	1,139 psi	3,669 psi	3,669 psi	3,669 psi	3,335 psi	3,335 psi	3,335 psi	3,335 psi
CL	1	1	1	1	1	1	1	1	1
<b>Shear and Moment</b>									
M	25,177 lb-in	44,759 lb-in	69,936 lb-in	100,708 lb-in	137,075 lb-in	179,036 lb-in	226,593 lb-in	279,744 lb-in	402,831 lb-in
V	2,797 lbs	3,730 lbs	4,662 lbs	5,595 lbs	6,527 lbs	7,460 lbs	8,392 lbs	9,325 lbs	11,190 lbs
<b>Stress</b>									
fb	958 psi	1,046 psi	1,328 psi	1,913 psi	2,604 psi	2,176 psi	2,755 psi	2,447 psi	2,698 psi
Fb'	1,235 psi	1,127 psi	3,598 psi	3,580 psi	3,562 psi	3,184 psi	3,156 psi	3,024 psi	2,712 psi
fb/Fb'	0.78	0.93	0.37	0.53	0.73	0.68	0.87	0.81	0.99
fv	193 psi	202 psi	210 psi	252 psi	294 psi	269 psi	303 psi	285 psi	300 psi
Fv'	219 psi	219 psi	334 psi	334 psi	334 psi	334 psi	334 psi	334 psi	334 psi
fv/Fv'	0.88	0.92	0.63	0.76	0.88	0.81	0.91	0.86	0.90
Max Ratio	0.88	0.93	0.63	0.76	0.88	0.81	0.91	0.86	0.99
	Pass	Pass	Pass	Pass	Pass	Pass	Pass	Pass	Pass
<b>Deflection</b>									
Δu	0.02 in	0.03 in	0.05 in	0.11 in	0.20 in	0.18 in	0.28 in	0.26 in	0.36 in
	L/1,615	L/1,415	L/1,144	L/662	L/417	L/546	L/383	L/458	L/395
Δu'	0.02 in	0.03 in	0.05 in	0.10 in	0.18 in	0.16 in	0.25 in	0.23 in	0.32 in
	L/1,825	L/1,599	L/1,293	L/748	L/471	L/617	L/433	L/517	L/447
	Pass	Pass	Pass	Pass	Pass	Pass	Pass	Pass	Pass

## Stud Wall - Combined Bending and Compression



Project Name: 19-07 Romine  
 Job Number: 2019-07873  
 Location: Valley County, Idaho  
 Engineer: SB  
 Checker: KJ

This spreadsheet is used for designing a stud wall according to the NDS. Inputs are in **Red** and outputs are in **BOLDFACE**.

### Overall Loading

Roof	Overhang	Span	Dead Load	Live / Snow Load	Total Load
	<b>4</b>	<b>8</b>	<b>136</b>	<b>1200</b>	
Floor		Span	Dead Load	Dead Load	
		<b>0</b>	<b>0</b>	<b>0</b>	
Wall	Plate Height	Header Height	Dead Load		
	<b>9</b>	<b>6.67</b>	<b>28</b>		
Total Load			<b>164 plf</b>	<b>1,200 plf</b>	<b>1,364 plf</b>

Description:	3 ft Opening	4 ft Opening	5 ft Opening	6 ft Opening	7 ft Opening	8 ft Opening	9 ft Opening	10 ft Opening	12 ft Opening
Header Callout	(2)2x6 DF-L No. 2	(2)2x10 DF-L No. 2	(2)2x12 DF-L No. 2	(2) 9-1/2" LVL 2.0E	(2) 9-1/2" LVL 2.0E	(2) 9-1/2" LVL 2.0E	(2) 11-7/8" LVL 2.0E	(2) 11-7/8" LVL 2.0E	(2) 14" LVL 2.0E
Trimmers	(1)2x DF #2	(1)2x DF #2	(2)2x DF #2	(2)2x DF #2	(2)2x DF #2	(2)2x DF #2	(2)2x DF #2	(3)2x DF #2	(3)2x DF #2
Wood Design									
Species	DF-L	DF-L	DF-L	LVL	LVL	LVL	LVL	LVL	LVL
Grade	No. 2	No. 2	No. 2	2.0E	2.0E	2.0E	2.0E	2.0E	2.0E
Width	3.00 in	3.00 in	3.00 in	3.50 in	3.50 in	3.50 in	3.50 in	3.50 in	3.50 in
Depth	5.50 in	9.25 in	11.25 in	9.50 in	9.50 in	9.50 in	11.88 in	11.88 in	14.00 in
Load									
ulu	3.0 ft	4.0 ft	5.0 ft	6.0 ft	7.0 ft	8.0 ft	9.0 ft	10.0 ft	12.0 ft
le	6.2 ft	8.2 ft	10.3 ft	12.2 ft	13.8 ft	15.4 ft	17.6 ft	19.3 ft	23.1 ft
Adjustment Factors									
Cd	1.15	1.15	1.15	1.15	1.15	1.15	1.15	1.15	1.15
CF	1.3	1.2	1.2	1.1	1.1	1.1	1	1	1
Material Properties									
Fb	900 psi	900 psi	900 psi	2,900 psi	2,900 psi	2,900 psi	2,900 psi	2,900 psi	2,900 psi
Fv	190 psi	190 psi	190 psi	290 psi	290 psi	290 psi	290 psi	290 psi	290 psi
E	1,600,000 psi	1,600,000 psi	1,600,000 psi	2,000,000 psi	2,000,000 psi	2,000,000 psi	2,000,000 psi	2,000,000 psi	2,000,000 psi
Emin	580,000 psi	580,000 psi	580,000 psi	1,016,535 psi	1,016,535 psi	1,016,535 psi	1,016,535 psi	1,016,535 psi	1,016,535 psi
Calculated Prop.									
A	16.50 in <sup>2</sup>	27.75 in <sup>2</sup>	33.75 in <sup>2</sup>	33.25 in <sup>2</sup>	33.25 in <sup>2</sup>	33.25 in <sup>2</sup>	41.56 in <sup>2</sup>	41.56 in <sup>2</sup>	49.00 in <sup>2</sup>
I	41.59 in <sup>4</sup>	197.86 in <sup>4</sup>	355.96 in <sup>4</sup>	250.07 in <sup>4</sup>	250.07 in <sup>4</sup>	250.07 in <sup>4</sup>	488.41 in <sup>4</sup>	488.41 in <sup>4</sup>	800.33 in <sup>4</sup>
S	15.13 in <sup>3</sup>	42.78 in <sup>3</sup>	63.28 in <sup>3</sup>	52.65 in <sup>3</sup>	52.65 in <sup>3</sup>	52.65 in <sup>3</sup>	82.26 in <sup>3</sup>	82.26 in <sup>3</sup>	114.33 in <sup>3</sup>
RB	6.73	10.08	12.43	10.64	11.33	11.98	14.32	14.97	17.78
Emin'	580,000 psi	580,000 psi	580,000 psi	1,016,535 psi	1,016,535 psi	1,016,535 psi	1,016,535 psi	1,016,535 psi	1,016,535 psi
FbE	15,357 psi	6,849 psi	4,505 psi	10,784 psi	9,509 psi	8,503 psi	5,945 psi	5,442 psi	3,857 psi
Fb*	1,346 psi	1,139 psi	1,035 psi	3,669 psi	3,669 psi	3,669 psi	3,335 psi	3,335 psi	3,335 psi
CL	1	1	1	1	1	1	1	1	1
Shear and Moment									
M	18,413 lb-in	32,735 lb-in	51,149 lb-in	73,654 lb-in	100,251 lb-in	130,940 lb-in	165,721 lb-in	204,594 lb-in	294,615 lb-in
V	2,046 lbs	2,728 lbs	3,410 lbs	4,092 lbs	4,774 lbs	5,456 lbs	6,138 lbs	6,820 lbs	8,184 lbs
Stress									
fb	1,217 psi	765 psi	808 psi	1,399 psi	1,904 psi	2,487 psi	2,015 psi	2,487 psi	2,577 psi
Fb'	1,339 psi	1,127 psi	1,020 psi	3,580 psi	3,562 psi	3,542 psi	3,156 psi	3,124 psi	2,898 psi
fb/Fb'	0.91	0.68	0.79	0.39	0.53	0.70	0.64	0.80	0.89
fv	186 psi	147 psi	152 psi	185 psi	215 psi	246 psi	222 psi	246 psi	251 psi
Fv'	219 psi	219 psi	219 psi	334 psi	334 psi	334 psi	334 psi	334 psi	334 psi
fv/Fv'	0.85	0.67	0.69	0.55	0.65	0.74	0.66	0.74	0.75
Max Ratio	0.91	0.68	0.79	0.55	0.65	0.74	0.66	0.80	0.89
	Pass	Pass	Pass	Pass	Pass	Pass	Pass	Pass	Pass
Deflection									
Δu	0.04 in	0.02 in	0.03 in	0.08 in	0.15 in	0.25 in	0.21 in	0.31 in	0.40 in
	L/964	L/1,934	L/1,782	L/905	L/570	L/382	L/524	L/382	L/362
Δu'	0.03 in	0.02 in	0.03 in	0.07 in	0.13 in	0.22 in	0.18 in	0.28 in	0.35 in
	L/1,095	L/2,198	L/2,025	L/1,029	L/648	L/434	L/596	L/434	L/412
	Pass	Pass	Pass	Pass	Pass	Pass	Pass	Pass	Pass

## Stud Wall - Combined Bending and Compression



Project Name: 19-07 Romine  
 Job Number: 2019-07873  
 Location: Valley County, Idaho  
 Engineer: SB  
 Checker: KJ

This spreadsheet is used for designing a stud wall according to the NDS. Inputs are in **Red** and outputs are in **BOLDFACE**.

### Overall Loading

Roof	Overhang	Span	Dead Load	Live / Snow Load	Total Load
	2	8	102	900	
Floor		Span	Dead Load	Dead Load	
		0	0	0	
Wall	Plate Height	Header Height	Dead Load		
	9	6.67	28		
Total Load			130 plf	900 plf	1,030 plf

Description:	3 ft Opening	4 ft Opening	5 ft Opening	6 ft Opening	7 ft Opening	8 ft Opening	9 ft Opening	10 ft Opening	12 ft Opening
<b>Header Callout</b>	(2)2x6 DF-L No. 2	(2)2x8 DF-L No. 2	(2)2x10 DF-L No. 2	(2)2x12 DF-L No. 2	(2) 9-1/2" LVL 2.0E	(2) 9-1/2" LVL 2.0E	(2) 9-1/2" LVL 2.0E	(2) 11-7/8" LVL 2.0E	(2) 14" LVL 2.0E
<b>Trimmers</b>	(1)2x DF #2	(1)2x DF #2	(1)2x DF #2	(2)2x DF #2	(2)2x DF #2	(2)2x DF #2	(2)2x DF #2	(2)2x DF #2	(2)2x DF #2
<b>Wood Design</b>									
Species	DF-L	DF-L	DF-L	DF-L	LVL	LVL	LVL	LVL	LVL
Grade	No. 2	No. 2	No. 2	No. 2	2.0E	2.0E	2.0E	2.0E	2.0E
Width	3.00 in	3.00 in	3.00 in	3.00 in	3.50 in	3.50 in	3.50 in	3.50 in	3.50 in
Depth	5.50 in	7.25 in	9.25 in	11.25 in	9.50 in	9.50 in	9.50 in	11.88 in	14.00 in
<b>Load</b>									
ulu	3.0 ft	4.0 ft	5.0 ft	6.0 ft	7.0 ft	8.0 ft	9.0 ft	10.0 ft	12.0 ft
le	6.2 ft	8.2 ft	10.3 ft	12.4 ft	13.8 ft	15.4 ft	17.0 ft	19.3 ft	23.1 ft
<b>Adjustment Factors</b>									
Cd	1.15	1.15	1.15	1.15	1.15	1.15	1.15	1.15	1.15
CF	1.3	1.2	1.2	1.2	1.1	1.1	1.1	1	1
<b>Material Properties</b>									
Fb	900 psi	900 psi	900 psi	900 psi	2,900 psi	2,900 psi	2,900 psi	2,900 psi	2,900 psi
Fv	190 psi	190 psi	190 psi	190 psi	290 psi	290 psi	290 psi	290 psi	290 psi
E	1,600,000 psi	1,600,000 psi	1,600,000 psi	1,600,000 psi	2,000,000 psi	2,000,000 psi	2,000,000 psi	2,000,000 psi	2,000,000 psi
Emin	580,000 psi	580,000 psi	580,000 psi	580,000 psi	1,016,535 psi	1,016,535 psi	1,016,535 psi	1,016,535 psi	1,016,535 psi
<b>Calculated Prop.</b>									
A	16.50 in <sup>2</sup>	21.75 in <sup>2</sup>	27.75 in <sup>2</sup>	33.75 in <sup>2</sup>	33.25 in <sup>2</sup>	33.25 in <sup>2</sup>	33.25 in <sup>2</sup>	41.56 in <sup>2</sup>	49.00 in <sup>2</sup>
I	41.59 in <sup>4</sup>	95.27 in <sup>4</sup>	197.86 in <sup>4</sup>	355.96 in <sup>4</sup>	250.07 in <sup>4</sup>	250.07 in <sup>4</sup>	250.07 in <sup>4</sup>	488.41 in <sup>4</sup>	800.33 in <sup>4</sup>
S	15.13 in <sup>3</sup>	26.28 in <sup>3</sup>	42.78 in <sup>3</sup>	63.28 in <sup>3</sup>	52.65 in <sup>3</sup>	52.65 in <sup>3</sup>	52.65 in <sup>3</sup>	82.26 in <sup>3</sup>	114.33 in <sup>3</sup>
RB	6.73	8.92	11.27	13.62	11.33	11.98	12.59	14.97	17.78
Emin	580,000 psi	580,000 psi	580,000 psi	580,000 psi	1,016,535 psi	1,016,535 psi	1,016,535 psi	1,016,535 psi	1,016,535 psi
FbE	15,357 psi	8,738 psi	5,479 psi	3,754 psi	9,509 psi	8,503 psi	7,690 psi	5,442 psi	3,857 psi
Fb*	1,346 psi	1,242 psi	1,139 psi	1,035 psi	3,669 psi	3,669 psi	3,669 psi	3,335 psi	3,335 psi
CL	1	1	1	1	1	1	1	1	1
<b>Shear and Moment</b>									
M	13,904 lb-in	24,719 lb-in	38,624 lb-in	55,618 lb-in	75,702 lb-in	98,876 lb-in	125,140 lb-in	154,494 lb-in	222,471 lb-in
V	1,545 lbs	2,060 lbs	2,575 lbs	3,090 lbs	3,605 lbs	4,120 lbs	4,635 lbs	5,150 lbs	6,180 lbs
<b>Stress</b>									
fb	919 psi	941 psi	903 psi	879 psi	1,438 psi	1,878 psi	2,377 psi	1,878 psi	1,946 psi
Fb'	1,339 psi	1,232 psi	1,124 psi	1,016 psi	3,562 psi	3,542 psi	3,520 psi	3,124 psi	2,898 psi
fb/Fb'	0.69	0.76	0.80	0.86	0.40	0.53	0.68	0.60	0.67
fv	140 psi	142 psi	139 psi	137 psi	163 psi	186 psi	209 psi	186 psi	189 psi
Fv'	219 psi	219 psi	219 psi	219 psi	334 psi	334 psi	334 psi	334 psi	334 psi
fv/Fv'	0.64	0.65	0.64	0.63	0.49	0.56	0.63	0.56	0.57
Max Ratio	0.69	0.76	0.80	0.86	0.49	0.56	0.68	0.60	0.67
	Pass	Pass	Pass	Pass	Pass	Pass	Pass	Pass	Pass
<b>Deflection</b>									
Δu	0.03 in	0.04 in	0.05 in	0.05 in	0.11 in	0.19 in	0.30 in	0.24 in	0.30 in
	L/1,276	L/1,233	L/1,311	L/1,365	L/755	L/506	L/355	L/506	L/480
Δu	0.02 in	0.03 in	0.04 in	0.05 in	0.10 in	0.17 in	0.27 in	0.21 in	0.26 in
	L/1,461	L/1,411	L/1,501	L/1,563	L/864	L/579	L/407	L/579	L/549
	Pass	Pass	Pass	Pass	Pass	Pass	Pass	Pass	Pass

## Stud Wall - Combined Bending and Compression



Project Name: 19-07 Romine  
 Job Number: 2019-07873  
 Location: Valley County, Idaho  
 Engineer: SB  
 Checker: KJ

This spreadsheet is used for designing a stud wall according to the NDS. Inputs are in **Red** and outputs are in **BOLDF**.

### Overall Loading

Roof	Overhang	Span	Dead Load	Live / Snow Load	Total Load
	2	28.5	276	2438	
Floor		Span	Dead Load	Dead Load	
		0	0	0	
Wall	Plate Height	Header Height	Dead Load		
	9	6.67	28		
Total Load			304 plf	2,438 plf	2,742 plf

Description:	3 ft Opening	4 ft Opening	5 ft Opening	6 ft Opening	7 ft Opening
<b>Header Callout</b>	(2)2x12 DF-L No. 2	(2) 9-1/2" LVL 2.0E	(2) 9-1/2" LVL 2.0E	(2) 11-7/8" LVL 2.0E	(2) 14" LVL 2.0E
<b>Trimmers</b>	(2)2x DF #2	(2)2x DF #2	(3)2x DF #2	(3)2x DF #2	(3)2x DF #2
<b>Wood Design</b>					
Species	DF-L	LVL	LVL	LVL	LVL
Grade	No. 2	2.0E	2.0E	2.0E	2.0E
Width	3.00 in	3.50 in	3.50 in	3.50 in	3.50 in
Depth	11.25 in	9.50 in	9.50 in	11.88 in	14.00 in
<b>Load</b>					
ulu	3.0 ft	4.0 ft	5.0 ft	6.0 ft	7.0 ft
le	6.2 ft	8.2 ft	10.3 ft	12.4 ft	14.4 ft
<b>Adjustment Factors</b>					
Cd	1.15	1.15	1.15	1.15	1.15
CF	1.2	1.2	1.1	1	1
<b>Material Properties</b>					
Fb	900 psi	2,900 psi	2,900 psi	2,900 psi	2,900 psi
Fv	190 psi	290 psi	290 psi	290 psi	290 psi
E	1,600,000 psi	2,000,000 psi	2,000,000 psi	2,000,000 psi	2,000,000 psi
Emin	580,000 psi	1,016,535 psi	1,016,535 psi	1,016,535 psi	1,016,535 psi
<b>Calculated Prop.</b>					
A	33.75 in <sup>2</sup>	33.25 in <sup>2</sup>	33.25 in <sup>2</sup>	41.56 in <sup>2</sup>	49.00 in <sup>2</sup>
I	355.96 in <sup>4</sup>	250.07 in <sup>4</sup>	250.07 in <sup>4</sup>	488.41 in <sup>4</sup>	800.33 in <sup>4</sup>
S	63.28 in <sup>3</sup>	52.65 in <sup>3</sup>	52.65 in <sup>3</sup>	82.26 in <sup>3</sup>	114.33 in <sup>3</sup>
RB	9.63	8.76	9.79	11.99	14.06
Emin'	580,000 psi	1,016,535 psi	1,016,535 psi	1,016,535 psi	1,016,535 psi
FbE	7,508 psi	15,908 psi	12,726 psi	8,484 psi	6,168 psi
Fb*	1,035 psi	3,669 psi	3,669 psi	3,335 psi	3,335 psi
CL	1	1	1	1	1
<b>Shear and Moment</b>					
M	37,013 lb-in	65,801 lb-in	102,814 lb-in	148,052 lb-in	201,516 lb-in
V	4,113 lbs	5,483 lbs	6,854 lbs	8,225 lbs	9,596 lbs
<b>Stress</b>					
fb	585 psi	1,250 psi	1,953 psi	1,800 psi	1,763 psi
Fb'	1,027 psi	3,615 psi	3,598 psi	3,235 psi	3,168 psi
fb/Fb'	0.57	0.35	0.54	0.56	0.56
fv	183 psi	247 psi	309 psi	297 psi	294 psi
Fv'	219 psi	334 psi	334 psi	334 psi	334 psi
fv/Fv'	0.84	0.74	0.93	0.89	0.88
Max Ratio	0.84	0.74	0.93	0.89	0.88
	Pass	Pass	Pass	Pass	Pass
<b>Deflection</b>					
Δu	0.01 in	0.03 in	0.08 in	0.08 in	0.09 in
	L/4,103	L/1,520	L/778	L/880	L/908
Δu	0.01 in	0.03 in	0.07 in	0.07 in	0.08 in
	L/4,615	L/1,710	L/875	L/990	L/1,021
	Pass	Pass	Pass	Pass	Pass

## Stud Wall - Combined Bending and Compression



Project Name: 19-07 Romine  
 Job Number: 2019-07873  
 Location: Valley County, Idaho  
 Engineer: SB  
 Checker: KJ

This spreadsheet is used for designing a stud wall according to the NDS. Inputs are in **Red** and outputs are in **BOLDFACE**.

### Overall Loading

Roof	Overhang	Span	Dead Load	Live / Snow Load	Total Load
	2	4	68	600	
Floor		Span	Dead Load	Dead Load	
		0	0	0	
Wall	Plate Height	Header Height	Dead Load		
	9	6.67	28		
Total Load			96 plf	600 plf	696 plf

Description:	3 ft Opening	4 ft Opening	5 ft Opening	6 ft Opening	7 ft Opening	8 ft Opening	9 ft Opening	10 ft Opening	12 ft Opening
<b>Header Callout</b>	(2)2x4 DF-L No. 2	(2)2x6 DF-L No. 2	(2)2x8 DF-L No. 2	(2)2x10 DF-L No. 2	(2)2x12 DF-L No. 2	(2) 9-1/2" LVL 2.0E	(2) 9-1/2" LVL 2.0E	(2) 9-1/2" LVL 2.0E	(2) 11-7/8" LVL 2.0E
<b>Trimmers</b>	(1)2x DF #2	(1)2x DF #2	(1)2x DF #2	(1)2x DF #2	(1)2x DF #2	(1)2x DF #2	(1)2x DF #2	(2)2x DF #2	(2)2x DF #2
<b>Wood Design</b>									
Species	DF-L	DF-L	DF-L	DF-L	DF-L	LVL	LVL	LVL	LVL
Grade	No. 2	No. 2	No. 2	No. 2	No. 2	2.0E	2.0E	2.0E	2.0E
Width	3.00 in	3.00 in	3.00 in	3.00 in	3.00 in	3.50 in	3.50 in	3.50 in	3.50 in
Depth	3.50 in	5.50 in	7.25 in	9.25 in	11.25 in	9.50 in	9.50 in	9.50 in	11.88 in
<b>Load</b>									
ulu	3.0 ft	4.0 ft	5.0 ft	6.0 ft	7.0 ft	8.0 ft	9.0 ft	10.0 ft	12.0 ft
le	5.8 ft	7.9 ft	10.0 ft	12.1 ft	14.2 ft	15.4 ft	17.0 ft	18.7 ft	22.5 ft
<b>Adjustment Factors</b>									
Cd	1.15	1.15	1.15	1.15	1.15	1.15	1.15	1.15	1.15
CF	1.5	1.3	1.2	1.2	1.2	1.1	1.1	1.1	1
<b>Material Properties</b>									
Fb	900 psi	900 psi	900 psi	900 psi	900 psi	2,900 psi	2,900 psi	2,900 psi	2,900 psi
Fv	190 psi	190 psi	190 psi	190 psi	190 psi	290 psi	290 psi	290 psi	290 psi
E	1,600,000 psi	1,600,000 psi	1,600,000 psi	1,600,000 psi	1,600,000 psi	2,000,000 psi	2,000,000 psi	2,000,000 psi	2,000,000 psi
Emin	580,000 psi	580,000 psi	580,000 psi	580,000 psi	580,000 psi	1,016,535 psi	1,016,535 psi	1,016,535 psi	1,016,535 psi
<b>Calculated Prop.</b>									
A	10.50 in <sup>2</sup>	16.50 in <sup>2</sup>	21.75 in <sup>2</sup>	27.75 in <sup>2</sup>	33.75 in <sup>2</sup>	33.25 in <sup>2</sup>	33.25 in <sup>2</sup>	33.25 in <sup>2</sup>	41.56 in <sup>2</sup>
I	10.72 in <sup>4</sup>	41.59 in <sup>4</sup>	95.27 in <sup>4</sup>	197.86 in <sup>4</sup>	355.96 in <sup>4</sup>	250.07 in <sup>4</sup>	250.07 in <sup>4</sup>	250.07 in <sup>4</sup>	488.41 in <sup>4</sup>
S	6.13 in <sup>3</sup>	15.13 in <sup>3</sup>	26.28 in <sup>3</sup>	42.78 in <sup>3</sup>	63.28 in <sup>3</sup>	52.65 in <sup>3</sup>	52.65 in <sup>3</sup>	52.65 in <sup>3</sup>	82.26 in <sup>3</sup>
RB	5.19	7.61	9.81	12.21	14.61	11.98	12.59	13.18	16.19
Emin'	580,000 psi	580,000 psi	580,000 psi	580,000 psi	580,000 psi	1,016,535 psi	1,016,535 psi	1,016,535 psi	1,016,535 psi
FbE	25,870 psi	12,021 psi	7,227 psi	4,667 psi	3,262 psi	8,503 psi	7,690 psi	7,019 psi	4,655 psi
Fb*	1,553 psi	1,346 psi	1,242 psi	1,139 psi	1,035 psi	3,669 psi	3,669 psi	3,669 psi	3,335 psi
CL	1	1	1	1	1	1	1	1	1
<b>Shear and Moment</b>									
M	9,395 lb-in	16,703 lb-in	26,099 lb-in	37,582 lb-in	51,153 lb-in	66,812 lb-in	84,559 lb-in	104,394 lb-in	150,327 lb-in
V	1,044 lbs	1,392 lbs	1,740 lbs	2,088 lbs	2,436 lbs	2,784 lbs	3,132 lbs	3,480 lbs	4,176 lbs
<b>Stress</b>									
fb	1,534 psi	1,104 psi	993 psi	878 psi	808 psi	1,269 psi	1,606 psi	1,983 psi	1,827 psi
Fb'	1,548 psi	1,337 psi	1,229 psi	1,121 psi	1,012 psi	3,542 psi	3,520 psi	3,495 psi	3,046 psi
fb/Fb'	0.99	0.83	0.81	0.78	0.80	0.36	0.46	0.57	0.60
fv	149 psi	127 psi	120 psi	113 psi	108 psi	126 psi	141 psi	157 psi	151 psi
Fv'	219 psi	219 psi	219 psi	219 psi	219 psi	334 psi	334 psi	334 psi	334 psi
fv/Fv'	0.68	0.58	0.55	0.52	0.50	0.38	0.42	0.47	0.45
Max Ratio	0.99	0.83	0.81	0.78	0.80	0.38	0.46	0.57	0.60
	Pass	Pass	Pass	Pass	Pass	Pass	Pass	Pass	Pass
<b>Deflection</b>									
Δu	0.07 in	0.06 in	0.06 in	0.06 in	0.07 in	0.13 in	0.21 in	0.31 in	0.33 in
	L/487	L/797	L/934	L/1,123	L/1,272	L/749	L/526	L/383	L/433
Δu	0.06 in	0.05 in	0.06 in	0.06 in	0.06 in	0.11 in	0.18 in	0.27 in	0.29 in
	L/565	L/924	L/1,084	L/1,303	L/1,476	L/868	L/610	L/445	L/502
	Pass	Pass	Pass	Pass	Pass	Pass	Pass	Pass	Pass

## Stud Wall - Combined Bending and Compression



Project Name: 19-07 Romine  
 Job Number: 2019-07873  
 Location: Valley County, Idaho  
 Engineer: SB  
 Checker: KJ

This spreadsheet is used for designing a stud wall according to the NDS. Inputs are in **Red** and outputs are in **BOLDFACE**.

### Overall Loading

Roof	Overhang	Span	Dead Load	Live / Snow Load	Total Load
	0	0	0	0	
Floor		Span	Dead Load	Dead Load	
		38	494	760	
Wall	Plate Height	Header Height	Dead Load		
	9	6.67	28		
Total Load			522 plf	760 plf	1,282 plf

Description:	3 ft Opening	4 ft Opening	5 ft Opening	6 ft Opening	7 ft Opening	8 ft Opening	9 ft Opening	10 ft Opening	12 ft Opening
<b>Header Callout</b>	(2)2x6 DF-L No. 2	(2)2x8 DF-L No. 2	(2)2x10 DF-L No. 2	(2) 9-1/2" LVL 2.0E	(2) 9-1/2" LVL 2.0E	(2) 9-1/2" LVL 2.0E	(2) 9-1/2" LVL 2.0E	(2) 11-7/8" LVL 2.0E	(2) 14" LVL 2.0E
<b>Trimmers</b>	(1)2x DF #2	(1)2x DF #2	(2)2x DF #2	(2)2x DF #2	(2)2x DF #2	(2)2x DF #2	(2)2x DF #2	(2)2x DF #2	(3)2x DF #2
<b>Wood Design</b>									
Species	DF-L	DF-L	DF-L	LVL	LVL	LVL	LVL	LVL	LVL
Grade	No. 2	No. 2	No. 2	2.0E	2.0E	2.0E	2.0E	2.0E	2.0E
Width	3.00 in	3.00 in	3.00 in	3.50 in	3.50 in	3.50 in	3.50 in	3.50 in	3.50 in
Depth	5.50 in	7.25 in	9.25 in	9.50 in	9.50 in	9.50 in	9.50 in	11.88 in	14.00 in
<b>Load</b>									
ulu	3.0 ft	4.0 ft	5.0 ft	6.0 ft	7.0 ft	8.0 ft	9.0 ft	10.0 ft	12.0 ft
le	6.2 ft	8.2 ft	10.3 ft	12.2 ft	13.8 ft	15.4 ft	17.0 ft	19.3 ft	23.1 ft
<b>Adjustment Factors</b>									
Cd	1.15	1.15	1.15	1.15	1.15	1.15	1.15	1.15	1.15
CF	1.3	1.2	1.2	1.2	1.1	1.1	1.1	1	1
<b>Material Properties</b>									
Fb	900 psi	900 psi	900 psi	2,900 psi	2,900 psi	2,900 psi	2,900 psi	2,900 psi	2,900 psi
Fv	190 psi	190 psi	190 psi	290 psi	290 psi	290 psi	290 psi	290 psi	290 psi
E	1,600,000 psi	1,600,000 psi	1,600,000 psi	2,000,000 psi	2,000,000 psi	2,000,000 psi	2,000,000 psi	2,000,000 psi	2,000,000 psi
Emin	580,000 psi	580,000 psi	580,000 psi	1,016,535 psi	1,016,535 psi	1,016,535 psi	1,016,535 psi	1,016,535 psi	1,016,535 psi
<b>Calculated Prop.</b>									
A	16.50 in <sup>2</sup>	21.75 in <sup>2</sup>	27.75 in <sup>2</sup>	33.25 in <sup>2</sup>	33.25 in <sup>2</sup>	33.25 in <sup>2</sup>	33.25 in <sup>2</sup>	41.56 in <sup>2</sup>	49.00 in <sup>2</sup>
I	41.59 in <sup>4</sup>	95.27 in <sup>4</sup>	197.86 in <sup>4</sup>	250.07 in <sup>4</sup>	250.07 in <sup>4</sup>	250.07 in <sup>4</sup>	250.07 in <sup>4</sup>	488.41 in <sup>4</sup>	800.33 in <sup>4</sup>
S	15.13 in <sup>3</sup>	26.28 in <sup>3</sup>	42.78 in <sup>3</sup>	52.65 in <sup>3</sup>	52.65 in <sup>3</sup>	52.65 in <sup>3</sup>	52.65 in <sup>3</sup>	82.26 in <sup>3</sup>	114.33 in <sup>3</sup>
RB	6.73	8.92	11.27	10.64	11.33	11.98	12.59	14.97	17.78
Emin'	580,000 psi	580,000 psi	580,000 psi	1,016,535 psi	1,016,535 psi	1,016,535 psi	1,016,535 psi	1,016,535 psi	1,016,535 psi
FbE	15,357 psi	8,738 psi	5,479 psi	10,784 psi	9,509 psi	8,503 psi	7,690 psi	5,442 psi	3,857 psi
Fb*	1,346 psi	1,242 psi	1,139 psi	3,669 psi	3,669 psi	3,669 psi	3,669 psi	3,335 psi	3,335 psi
CL	1	1	1	1	1	1	1	1	1
<b>Shear and Moment</b>									
M	17,306 lb-in	30,767 lb-in	48,074 lb-in	69,226 lb-in	94,224 lb-in	123,068 lb-in	155,758 lb-in	192,294 lb-in	276,903 lb-in
V	1,923 lbs	2,564 lbs	3,205 lbs	3,846 lbs	4,487 lbs	5,128 lbs	5,769 lbs	6,410 lbs	7,050 lbs
<b>Stress</b>									
fb	1,144 psi	1,171 psi	1,124 psi	1,315 psi	1,790 psi	2,338 psi	2,959 psi	2,338 psi	2,422 psi
Fb'	1,339 psi	1,232 psi	1,124 psi	3,580 psi	3,562 psi	3,542 psi	3,520 psi	3,124 psi	2,898 psi
fb/Fb'	0.85	0.95	1.00	0.37	0.50	0.66	0.84	0.75	0.84
fv	175 psi	177 psi	173 psi	173 psi	202 psi	231 psi	260 psi	231 psi	235 psi
Fv'	219 psi	219 psi	219 psi	334 psi	334 psi	334 psi	334 psi	334 psi	334 psi
fv/Fv'	0.80	0.81	0.79	0.52	0.61	0.69	0.78	0.69	0.71
Max Ratio	0.85	0.95	1.00	0.52	0.61	0.69	0.84	0.75	0.84
	Pass	Pass	Pass	Pass	Pass	Pass	Pass	Pass	Pass
<b>Deflection</b>									
Δu	0.04 in	0.05 in	0.06 in	0.07 in	0.14 in	0.24 in	0.38 in	0.30 in	0.37 in
	L/1,025	L/991	L/1,054	L/963	L/607	L/406	L/285	L/406	L/385
Δu'	0.02 in	0.03 in	0.03 in	0.04 in	0.08 in	0.14 in	0.22 in	0.18 in	0.22 in
	L/1,730	L/1,671	L/1,777	L/1,625	L/1,023	L/685	L/481	L/685	L/650
	Pass	Pass	Pass	Pass	Pass	Pass	Pass	Pass	Pass

## Stud Wall - Combined Bending and Compression



Project Name: 19-07 Romine  
 Job Number: 2019-07873  
 Location: Valley County, Idaho  
 Engineer: SB  
 Checker: KJ

This spreadsheet is used for designing a stud wall according to the NDS. Inputs are in **Red** and outputs are in **BOLDFACE**.

### Overall Loading

Roof	Overhang	Span	Dead Load	Live / Snow Load	Total Load
	2	10	119	1050	
Floor		Span	Dead Load	Dead Load	
		0	0	0	
Wall	Plate Height	Header Height	Dead Load		
	9	6.67	28		
Total Load			147 plf	1,050 plf	1,197 plf

Description:	3 ft Opening	4 ft Opening	5 ft Opening	6 ft Opening	7 ft Opening	8 ft Opening	9 ft Opening	10 ft Opening	12 ft Opening
<b>Header Callout</b>	(2)2x6 DF-L No. 2	(2)2x8 DF-L No. 2	(2)2x10 DF-L No. 2	(2) 9-1/2" LVL 2.0E	(2) 9-1/2" LVL 2.0E	(2) 9-1/2" LVL 2.0E	(2) 11-7/8" LVL 2.0E	(2) 11-7/8" LVL 2.0E	(2) 14" LVL 2.0E
<b>Trimmers</b>	(1)2x DF #2	(1)2x DF #2	(2)2x DF #2	(2)2x DF #2	(2)2x DF #2	(2)2x DF #2	(2)2x DF #2	(2)2x DF #2	(3)2x DF #2
<b>Wood Design</b>									
Species	DF-L	DF-L	DF-L	LVL	LVL	LVL	LVL	LVL	LVL
Grade	No. 2	No. 2	No. 2	2.0E	2.0E	2.0E	2.0E	2.0E	2.0E
Width	3.00 in	3.00 in	3.00 in	3.50 in	3.50 in	3.50 in	3.50 in	3.50 in	3.50 in
Depth	5.50 in	7.25 in	9.25 in	9.50 in	9.50 in	9.50 in	11.88 in	11.88 in	14.00 in
<b>Load</b>									
ulu	3.0 ft	4.0 ft	5.0 ft	6.0 ft	7.0 ft	8.0 ft	9.0 ft	10.0 ft	12.0 ft
le	6.2 ft	8.2 ft	10.3 ft	12.2 ft	13.8 ft	15.4 ft	17.6 ft	19.3 ft	23.1 ft
<b>Adjustment Factors</b>									
Cd	1.15	1.15	1.15	1.15	1.15	1.15	1.15	1.15	1.15
CF	1.3	1.2	1.2	1.1	1.1	1.1	1	1	1
<b>Material Properties</b>									
Fb	900 psi	900 psi	900 psi	2,900 psi	2,900 psi	2,900 psi	2,900 psi	2,900 psi	2,900 psi
Fv	190 psi	190 psi	190 psi	290 psi	290 psi	290 psi	290 psi	290 psi	290 psi
E	1,600,000 psi	1,600,000 psi	1,600,000 psi	2,000,000 psi	2,000,000 psi	2,000,000 psi	2,000,000 psi	2,000,000 psi	2,000,000 psi
Emin	580,000 psi	580,000 psi	580,000 psi	1,016,535 psi	1,016,535 psi	1,016,535 psi	1,016,535 psi	1,016,535 psi	1,016,535 psi
<b>Calculated Prop.</b>									
A	16.50 in <sup>2</sup>	21.75 in <sup>2</sup>	27.75 in <sup>2</sup>	33.25 in <sup>2</sup>	33.25 in <sup>2</sup>	33.25 in <sup>2</sup>	41.56 in <sup>2</sup>	41.56 in <sup>2</sup>	49.00 in <sup>2</sup>
I	41.59 in <sup>4</sup>	95.27 in <sup>4</sup>	197.86 in <sup>4</sup>	250.07 in <sup>4</sup>	250.07 in <sup>4</sup>	250.07 in <sup>4</sup>	488.41 in <sup>4</sup>	488.41 in <sup>4</sup>	800.33 in <sup>4</sup>
S	15.13 in <sup>3</sup>	26.28 in <sup>3</sup>	42.78 in <sup>3</sup>	52.65 in <sup>3</sup>	52.65 in <sup>3</sup>	52.65 in <sup>3</sup>	82.26 in <sup>3</sup>	82.26 in <sup>3</sup>	114.33 in <sup>3</sup>
RB	6.73	8.92	11.27	10.64	11.33	11.98	14.32	14.97	17.78
Emin'	580,000 psi	580,000 psi	580,000 psi	1,016,535 psi	1,016,535 psi	1,016,535 psi	1,016,535 psi	1,016,535 psi	1,016,535 psi
FbE	15,357 psi	8,738 psi	5,479 psi	10,784 psi	9,509 psi	8,503 psi	5,945 psi	5,442 psi	3,857 psi
Fb*	1,346 psi	1,242 psi	1,139 psi	3,669 psi	3,669 psi	3,669 psi	3,335 psi	3,335 psi	3,335 psi
CL	1	1	1	1	1	1	1	1	1
<b>Shear and Moment</b>									
M	16,159 lb-in	28,727 lb-in	44,886 lb-in	64,636 lb-in	87,977 lb-in	114,908 lb-in	145,431 lb-in	179,544 lb-in	258,543 lb-in
V	1,795 lbs	2,394 lbs	2,992 lbs	3,591 lbs	4,189 lbs	4,788 lbs	5,386 lbs	5,985 lbs	7,182 lbs
<b>Stress</b>									
fb	1,068 psi	1,093 psi	1,049 psi	1,228 psi	1,671 psi	2,183 psi	1,768 psi	2,183 psi	2,261 psi
Fb'	1,339 psi	1,232 psi	1,124 psi	3,580 psi	3,562 psi	3,542 psi	3,156 psi	3,124 psi	2,898 psi
fb/Fb'	0.80	0.89	0.93	0.34	0.47	0.62	0.56	0.70	0.78
fv	163 psi	165 psi	162 psi	162 psi	189 psi	216 psi	194 psi	216 psi	220 psi
Fv'	219 psi	219 psi	219 psi	334 psi	334 psi	334 psi	334 psi	334 psi	334 psi
fv/Fv'	0.75	0.76	0.74	0.49	0.57	0.65	0.58	0.65	0.66
Max Ratio	0.80	0.89	0.93	0.49	0.57	0.65	0.58	0.70	0.78
	Pass	Pass	Pass	Pass	Pass	Pass	Pass	Pass	Pass
<b>Deflection</b>									
Δu	0.03 in	0.05 in	0.05 in	0.07 in	0.13 in	0.22 in	0.18 in	0.28 in	0.35 in
	L/1,098	L/1,061	L/1,128	L/1,032	L/650	L/435	L/597	L/435	L/413
Δu'	0.03 in	0.04 in	0.05 in	0.06 in	0.11 in	0.19 in	0.16 in	0.24 in	0.31 in
	L/1,252	L/1,210	L/1,286	L/1,176	L/741	L/496	L/681	L/496	L/471
	Pass	Pass	Pass	Pass	Pass	Pass	Pass	Pass	Pass

## Stud Wall - Combined Bending and Compression



Project Name: 19-07 Romine  
 Job Number: 2019-07873  
 Location: Valley County, Idaho  
 Engineer: SB  
 Checker: KJ

This spreadsheet is used for designing a stud wall according to the NDS.  
 Inputs are in **ITALICS** and outputs are in **BOLDFACE**.

Description:	<b>10' Tall Wall</b>			
	Species	<i>DF-L</i>		
	Grade	<i>No. 2</i>		
nominal width	t =	<b>2</b>	in	1.50 in
nominal depth	d =	<b>6</b>	in	5.50 in
Span	L =	<b>10</b>	ft	9.750 ft
stud spacing	s =	<b>16</b>	in	<i>w/o Plates</i>
Lateral pressure	<i>w<sub>wind</sub></i> =	<i>14.56</i>	psf	
axial load	P =	<b>3205</b>	lbs	
eccentricity	e =	<b>0</b>	in	
	<i>K<sub>cE</sub></i> =	<i>0.3</i>		
Buckling and crushing	<i>c</i> =	<i>0.8</i>		
interaction factor for	w =	<b>19.4</b>	plf	
	<i>F<sub>b</sub></i>	<i>F<sub>v</sub></i>	<i>F<sub>c</sub></i>	<i>F<sub>c-perp</sub></i>
	900 psi	190 psi	1,350 psi	625 psi
<i>C<sub>d</sub></i> =	<b>1.60</b>	<b>1.60</b>	<b>1.60</b>	
<i>C<sub>F</sub></i> =	<b>1.30</b>		<b>1.10</b>	
<i>C<sub>r</sub></i> =	<b>1.15</b>			
<i>C<sub>p</sub></i> =			0.39	
<i>C<sub>H</sub></i> =		<b>1.00</b>		
<i>C<sub>b</sub></i> =				1.07
	<i>E</i>	<i>E<sub>min</sub></i>		
	1,600,000 psi	580,000 psi		
<b>Allowable Stress:</b>				
<i>F<sub>b</sub></i> ' =	<i>F<sub>b</sub> C<sub>d</sub> C<sub>F</sub> C<sub>r</sub></i> =	<b>2,153 psi</b>		
<i>F<sub>v</sub></i> ' =	<i>F<sub>v</sub> C<sub>d</sub> C<sub>H</sub></i> =	<b>304 psi</b>		
<i>F<sub>c</sub></i> ' =	<i>F<sub>c</sub> C<sub>d</sub> C<sub>F</sub></i> =	<b>2,376 psi</b>		
<i>F<sub>cE</sub></i> ' =	<i>(K<sub>cE</sub> E') / (l/d)<sup>2</sup></i> =	<b>1,061 psi</b>		
<i>F<sub>c</sub></i> ' =	<i>F<sub>c</sub> C<sub>d</sub> C<sub>F</sub> C<sub>p</sub></i> =	<b>938 psi</b>		
<i>F<sub>c-perp</sub></i> ' =	<i>F<sub>c-perp</sub> C<sub>b</sub></i> =	<b>668 psi</b>		
<i>E</i> ' =	<i>E</i> =	<b>1,600,000 psi</b>		
<i>R<sub>B</sub></i> ' =		<b>17 &lt; 50 OK</b>		
<i>F<sub>bE</sub></i> ' =		<b>2434 psi</b>		
<b>Bending:</b>				
<i>M</i> =	<i>w L<sup>2</sup> / 8 + P e / 12</i> =	<b>231 lb ft</b>		
<i>f<sub>b</sub></i> ' =	<i>M / S</i> =	<b>366 psi</b>		
	<i>S</i> =	<b>7.56 in<sup>3</sup></b>		
		<b>&lt; F'b OK</b>		
<b>Shear:</b>				
<i>V</i> =	<i>w L / 2</i> =	<b>71 lbs</b>		
<i>f<sub>v</sub></i> ' =	<i>1.5 V / A</i> =	<b>12.91 psi</b>		
	<i>A</i> =	<b>8.25 in<sup>2</sup></b>		
		<b>&lt; F'v OK</b>		
<b>Compression:</b>				
<i>f<sub>c</sub></i> ' =	<i>P / A</i> =	<b>388.5 psi</b>		
		<b>&lt; F'c OK</b>		
<i>f<sub>c-perp</sub></i> ' =	<i>P / A</i> =	<b>388.5 psi</b>		
		<b>&lt; F'c OK</b>		
<b>Combined:</b>				
	<i>((c/Fc)<sup>2</sup> + {fb/[Fb(1-(c/FcE])})}</i> =	<b>0.44</b>		
		<b>&lt; 1.0 OK</b>		
<b>Deflection:</b>				
$\Delta$ =	<i>22.5 w L<sup>4</sup> / E' I</i> =	<b>0.12 in</b>	=	<b>SPAN</b>
	<i>I</i> =	<b>20.80 in<sup>4</sup></b>		
		<b>986</b>		
		<b>&gt; 180 OK</b>		

## Stud Wall - Combined Bending and Compression



Project Name: 19-07 Romine  
 Job Number: 2019-07873  
 Location: Valley County, Idaho  
 Engineer: SB  
 Checker: KJ

This spreadsheet is used for designing a stud wall according to the NDS.  
 Inputs are in **ITALICS** and outputs are in **BOLDFACE**.

Description:	16' Tall Wall	King Stud (5' Max Opening)	16' Trimmer
	Species Grade	Species Grade	Species Grade
	<i>DF-L</i> <b>No. 2</b>	<i>DF-L</i> <b>No. 2</b>	<i>DF-L</i> <b>No. 2</b>
nominal width	t = <b>2</b> in	t = <b>(2) 2</b> in	t = <b>(2) 2</b> in
nominal depth	d = <b>6</b> in	d = <b>6</b> in	d = <b>6</b> in
Span	L = <b>16</b> ft	L = <b>16</b> ft	L = <b>16</b> ft
stud spacing	s = <b>12</b> in	s = <b>38.25</b> in	s = <b>12</b> in
Lateral pressure	W <sub>wind</sub> = 14.56 psf	W <sub>wind</sub> = 14.56 psf	W <sub>wind</sub> = 5.00 psf
axial load	P = 1169 lbs	P = 50 lbs	P = 2923 lbs
eccentricity	e = <b>0</b> in	e = <b>0</b> in	e = <b>0</b> in
Buckling and crushing interaction factor for	K <sub>cE</sub> = <b>0.3</b> c = <b>0.8</b> w = 14.6 plf	K <sub>cE</sub> = <b>0.3</b> c = <b>0.8</b> w = 46.4 plf	K <sub>cE</sub> = <b>0.3</b> c = <b>0.8</b> w = 5.0 plf
	F <sub>b</sub>	F <sub>b</sub>	F <sub>b</sub>
	900 psi	900 psi	900 psi
	F <sub>v</sub>	F <sub>v</sub>	F <sub>v</sub>
	190 psi	190 psi	190 psi
	F <sub>c</sub>	F <sub>c</sub>	F <sub>c</sub>
	1,350 psi	1,350 psi	1,350 psi
	F <sub>c-perp</sub>	F <sub>c-perp</sub>	F <sub>c-perp</sub>
	625 psi	625 psi	625 psi
C <sub>d</sub> =	<b>1.60</b>	<b>1.60</b>	<b>1.15</b>
C <sub>F</sub> =	<b>1.30</b>	<b>1.30</b>	<b>1.30</b>
C <sub>r</sub> =	<b>1.15</b>	<b>1.00</b>	<b>1.10</b>
C <sub>p</sub> =	<b>0.16</b>	<b>0.16</b>	<b>0.22</b>
C <sub>H</sub> =	<b>1.00</b>	<b>1.00</b>	<b>1.00</b>
C <sub>b</sub> =	<b>1.07</b>	<b>1.07</b>	<b>1.07</b>
	E	E	E
	1,600,000 psi	1,600,000 psi	1,600,000 psi
	E <sub>min</sub>	E <sub>min</sub>	E <sub>min</sub>
	580,000 psi	580,000 psi	580,000 psi
<b>Allowable Stress:</b>			
F' <sub>b</sub> = F <sub>b</sub> C <sub>d</sub> C <sub>F</sub> C <sub>r</sub> =	<b>2,153</b> psi	<b>1,872</b> psi	<b>1,346</b> psi
F' <sub>v</sub> = F <sub>v</sub> C <sub>d</sub> C <sub>H</sub> =	<b>304</b> psi	<b>304</b> psi	<b>219</b> psi
F' <sub>c</sub> = F <sub>c</sub> C <sub>d</sub> C <sub>F</sub> =	<b>2,376</b> psi	<b>2,376</b> psi	<b>1,708</b> psi
F' <sub>cE</sub> = (K <sub>cE</sub> E') / (l <sub>d</sub> /d) <sup>2</sup> =	<b>406</b> psi	<b>406</b> psi	<b>406</b> psi
F' <sub>c</sub> = F <sub>c</sub> C <sub>d</sub> C <sub>F</sub> C <sub>p</sub> =	<b>391</b> psi	<b>391</b> psi	<b>384</b> psi
F' <sub>c-perp</sub> = F <sub>c-perp</sub> C <sub>b</sub> =	<b>668</b> psi	<b>668</b> psi	<b>668</b> psi
E' =	<b>1,600,000</b> psi	<b>1,600,000</b> psi	<b>1,600,000</b> psi
R <sub>B</sub> =	<b>21 &lt; 50 OK</b>	<b>11 &lt; 50 OK</b>	<b>11 &lt; 50 OK</b>
F <sub>bE</sub> =	<b>1506</b> psi	<b>6026</b> psi	<b>6026</b> psi
<b>Bending:</b>			
M = w L <sup>2</sup> /8 + P e/12 =	452 lb ft	1439 lb ft	155 lb ft
f <sub>b</sub> = M/S =	<b>717</b> psi	<b>1142</b> psi	<b>123</b> psi
	S = 7.56 in <sup>3</sup>	S = 15.13 in <sup>3</sup>	S = 15.13 in <sup>3</sup>
<b>Shear:</b>			
V = w L/2 =	115 lbs	115 lbs	39 lbs
f <sub>v</sub> = 1.5 V/A =	<b>20.85</b> psi	<b>10.43</b> psi	<b>3.58</b> psi
	A = 8.25 in <sup>2</sup>	A = 16.50 in <sup>2</sup>	A = 16.50 in <sup>2</sup>
<b>Compression:</b>			
f <sub>c</sub> = P/A =	<b>141.7</b> psi	<b>3.0</b> psi	<b>177.1</b> psi
f <sub>c-perp</sub> = P/A =	<b>141.7</b> psi	<b>3.0</b> psi	<b>177.1</b> psi
<b>Combined:</b>			
((f <sub>c</sub> /F <sub>c</sub> ) <sup>2</sup> + {f <sub>b</sub> /[F <sub>b</sub> (1-(f <sub>c</sub> /F <sub>cE</sub> ))]} =	<b>0.64</b>	<b>0.61</b>	<b>0.37</b>
<b>Deflection:</b>			
Δ = 22.5 w L <sup>4</sup> /E' I =	<b>0.61</b> in	<b>0.97</b> in	<b>0.10</b> in
	I = 20.80 in <sup>4</sup>	I = 41.59 in <sup>4</sup>	I = 41.59 in <sup>4</sup>
	<b>SPAN</b> <b>312</b> <b>&gt; 180 OK</b>	<b>SPAN</b> <b>196</b> <b>&gt; 180 OK</b>	<b>SPAN</b> <b>1817</b> <b>&gt; 180 OK</b>



Project # : 2019-07873  
 Project: 19-07 Romine

## Individual Footing Design

Program: *Continuous Footing Design*

**Description:**

Inputs are in *ITALICS* and outputs are in **BOLDFACE**.

Soil Bearing Pressure: *1500psf*

**Roof**

Roof Dead ( *17psf* ) ( *16.7ft* ) = **283plf**  
 Snow Live ( *150psf* ) ( *16.7ft* ) = **2501plf**

**Upper Floor**

Floor Dead ( *26psf* ) ( *7.0ft* ) = **182plf**  
 Floor Live ( *40psf* ) ( *7.0ft* ) = **280plf**

**Main Floor**

Floor Dead ( *26psf* ) ( *5.0ft* ) = **130plf**  
 Floor Live ( *40psf* ) ( *5.0ft* ) = **200plf**

**Deck Cover**

Roof Dead ( *17psf* ) ( *5.0ft* ) = **85plf**  
 Snow Live ( *150psf* ) ( *5.0ft* ) = **750plf**

**Deck Cover**

Roof Dead ( *17psf* ) ( *5.0ft* ) = **85plf**  
 Snow Live ( *150psf* ) ( *5.0ft* ) = **750plf**

**Misc**

Wall Load: ( *12psf* ) ( *10.0ft* ) = **120plf**  
 Conc Stem: ( *145pcf* ) ( *2 x .5ft* ) = **145plf**  
 Misc Load: ( *.0ft* ) ( *.0ft* ) ( *.0ft* ) = **plf**

**5511plf**

Use Footing Width:	<b>54 x 10 in</b>
W/	<b>(5) #4 Cont.</b>



Project # : 2019-07873  
 Project: 19-07 Romine

## Individual Footing Design

Program: *Continuous Footing Design (2)*

### Description:

Inputs are in *ITALICS* and outputs are in **BOLDFACE**.

Soil Bearing Pressure: *1500psf*

#### Roof

Roof Dead ( *17psf* ) ( *22.5ft* ) = **383plf**  
 Snow Live ( *150psf* ) ( *22.5ft* ) = **3375plf**

#### Upper Floor

Floor Dead ( *26psf* ) ( *7.0ft* ) = **182plf**  
 Floor Live ( *40psf* ) ( *7.0ft* ) = **280plf**

#### Main Floor

Floor Dead ( *26psf* ) ( *5.0ft* ) = **130plf**  
 Floor Live ( *40psf* ) ( *5.0ft* ) = **200plf**

#### Deck Cover

Roof Dead ( *17psf* ) ( *.0ft* ) = **plf**  
 Snow Live ( *150psf* ) ( *.0ft* ) = **plf**

#### Deck Cover

Roof Dead ( *17psf* ) ( *.0ft* ) = **plf**  
 Snow Live ( *150psf* ) ( *.0ft* ) = **plf**

#### Misc

Wall Load: ( *12psf* ) ( *10.0ft* ) = **120plf**  
 Conc Stem: ( *145pcf* ) ( *2 x .5ft* ) = **145plf**  
 Misc Load: ( *.0ft* ) ( *.0ft* ) ( *.0ft* ) = **plf**

**4814plf**

Use Footing Width:	<b>48 x 10 in</b>
W/	<b>(4) #4 Cont.</b>



Project # : 2019-07873  
 Project: 19-07 Romine

## Individual Footing Design

Program: **Continuous Footing Design (3)**

### Description:

Inputs are in **ITALICS** and outputs are in **BOLDFACE**.

Soil Bearing Pressure: 1500psf

#### Roof

Roof Dead ( 17psf ) ( 11.0ft ) = **187plf**  
 Snow Live ( 150psf ) ( 11.0ft ) = **1650plf**

#### Upper Floor

Floor Dead ( 26psf ) ( .0ft ) = **plf**  
 Floor Live ( 40psf ) ( .0ft ) = **plf**

#### Main Floor

Floor Dead ( 26psf ) ( 4.0ft ) = **104plf**  
 Floor Live ( 40psf ) ( 4.0ft ) = **160plf**

#### Deck Cover

Roof Dead ( 17psf ) ( .0ft ) = **plf**  
 Snow Live ( 150psf ) ( .0ft ) = **plf**

#### Deck Cover

Roof Dead ( 17psf ) ( .0ft ) = **plf**  
 Snow Live ( 150psf ) ( .0ft ) = **plf**

#### Misc

Wall Load: ( 12psf ) ( 10.0ft ) = **120plf**  
 Conc Stem: ( 145pcf ) ( 2 x .5ft ) = **145plf**  
 Misc Load: ( .0ft ) ( .0ft ) ( .0ft ) = **plf**

**2366plf**

Use Footing Width:	<b>24 x 8 in</b>
W/	<b>(2) #4 Cont.</b>



Project # : 2019-07873  
 Project: 19-07 Romine

## Individual Footing Design

Program: *Continuous Footing Design (4)*

**Description:**

Inputs are in *ITALICS* and outputs are in **BOLDFACE**.

Soil Bearing Pressure: 1500psf

<b>Roof</b>			
Roof Dead ( 17psf )	<i>( 4.0ft )</i>	=	<b>68plf</b>
Snow Live ( 150psf )	<i>( 4.0ft )</i>	=	<b>600plf</b>
<b>Upper Floor</b>			
Floor Dead ( 26psf )	<i>( 2.0ft )</i>	=	<b>52plf</b>
Floor Live ( 40psf )	<i>( 2.0ft )</i>	=	<b>80plf</b>
<b>Main Floor</b>			
Floor Dead ( 26psf )	<i>( 4.0ft )</i>	=	<b>104plf</b>
Floor Live ( 40psf )	<i>( 4.0ft )</i>	=	<b>160plf</b>
<b>Deck Cover</b>			
Roof Dead ( 17psf )	<i>( 3.0ft )</i>	=	<b>51plf</b>
Snow Live ( 150psf )	<i>( 3.0ft )</i>	=	<b>450plf</b>
<b>Deck Cover</b>			
Roof Dead ( 17psf )	<i>( 3.0ft )</i>	=	<b>51plf</b>
Snow Live ( 150psf )	<i>( 3.0ft )</i>	=	<b>450plf</b>
<b>Misc</b>			
Wall Load: ( 12psf )	<i>( 10.0ft )</i>	=	<b>120plf</b>
Conc Stem: ( 145pcf )	<i>( 2 x .5ft )</i>	=	<b>145plf</b>
Misc Load: ( .0ft )	<i>( .0ft ) ( .0ft )</i>	=	<b>plf</b>
			<b>2331plf</b>

Use Footing Width:	<b>24 x 8 in</b>
W/	<b>(2) #4 Cont.</b>



Project # : 2019-07873  
 Project: 19-07 Romine

## Individual Footing Design

Program: *Continuous Footing Design (5)*

**Description:**

Inputs are in *ITALICS* and outputs are in **BOLDFACE**.

Soil Bearing Pressure: 1500psf

<b>Roof</b>			
Roof Dead ( 17psf )	<i>( 4.0ft )</i>	=	<b>68plf</b>
Snow Live ( 150psf )	<i>( 4.0ft )</i>	=	<b>600plf</b>
<b>Upper Floor</b>			
Floor Dead ( 26psf )	<i>( 2.0ft )</i>	=	<b>52plf</b>
Floor Live ( 40psf )	<i>( 2.0ft )</i>	=	<b>80plf</b>
<b>Main Floor</b>			
Floor Dead ( 26psf )	<i>( 2.0ft )</i>	=	<b>52plf</b>
Floor Live ( 40psf )	<i>( 2.0ft )</i>	=	<b>80plf</b>
<b>Deck Cover</b>			
Roof Dead ( 17psf )	<i>( 4.0ft )</i>	=	<b>68plf</b>
Snow Live ( 150psf )	<i>( 4.0ft )</i>	=	<b>600plf</b>
<b>Deck Cover</b>			
Roof Dead ( 17psf )	<i>( .0ft )</i>	=	<b>plf</b>
Snow Live ( 150psf )	<i>( .0ft )</i>	=	<b>plf</b>
<b>Misc</b>			
Wall Load: ( 12psf )	<i>( 10.0ft )</i>	=	<b>120plf</b>
Conc Stem: ( 145pcf )	<i>( 2 x .5ft )</i>	=	<b>145plf</b>
Misc Load: ( .0ft )	<i>( .0ft ) ( .0ft )</i>	=	<b>plf</b>
			<b>1865plf</b>

Use Footing Width:	<b>18 x 8 in</b>
W/	<b>(2) #4 Cont.</b>



Project # : 2019-07873  
 Project: 19-07 Romine

## Individual Footing Design

Program: *Pony Wall Footing Design*

### Description:

Inputs are in *ITALICS* and outputs are in **BOLDFACE**.

Soil Bearing Pressure: 1500psf

#### Main Floor

Floor Dead ( 26psf )	( 10.0ft )	=	<b>260plf</b>
Floor Live ( 40psf )	( 10.0ft )	=	<b>400plf</b>

#### Misc

Wall Load: ( 12psf )	( 10.0ft )	=	<b>120plf</b>
Conc Stem: ( 145pcf )	( 2 x .5ft )	=	<b>145plf</b>
Misc Load: ( .0ft )	( .0ft ) ( .0ft )	=	<b>plf</b>

**925plf**

Use Footing Width:	<b>12 x 8 in</b>
W/	<b>(2) #4 Cont.</b>



Project # : 2019-07873  
 Project: 19-07 Romine

## **Pad Footing Design Capacities**

Soil Bearing (1500 psf)					Min. Column Size		
Dimensions (Inches)			Capacity	# of Bars			
72	x	72	x	10	47,500 lbs	8	3.5 sq.
66	x	66	x	10	39,750 lbs	7	3.5 sq.
60	x	60	x	8	33,450 lbs	6	3.5 sq.
54	x	54	x	8	27,000 lbs	5	3.5 sq.
48	x	48	x	8	21,500 lbs	4	3.5 sq.
42	x	42	x	8	16,500 lbs	4	3.5 sq.
36	x	36	x	8	12,000 lbs	3	3.5 sq.
30	x	30	x	8	8,350 lbs	3	3.5 sq.
24	x	24	x	8	5,300 lbs	2	3.5 sq.
18	x	18	x	8	2,900 lbs	2	3.5 sq.

Bars to be 3 1/2" from bottom of pad. Evenly space in both directions.



## General Footing

Lic. # : KW-06007473

Description : 24"x24"x8" Pad Footing

File = U:\Desktop\Folders\2018-0\CALCUL-1107 Foundation.ec6 .  
Software copyright ENERCALC, INC. 1983-2018, Build:10.18.11.30 .

Licensee : SHAWN REEDER

### Code References

Calculations per ACI 318-14, IBC 2015, CBC 2016, ASCE 7-10  
Load Combinations Used : IBC 2015

### General Information

#### Material Properties

$f_c$ : Concrete 28 day strength	=	2.50 ksi
$f_y$ : Rebar Yield	=	60.0 ksi
$E_c$ : Concrete Elastic Modulus	=	3,122.0 ksi
Concrete Density	=	145.0 pcf
$\phi$ Values Flexure	=	0.90
Shear	=	0.750

#### Soil Design Values

Allowable Soil Bearing	=	1.50 ksf
Increase Bearing By Footing Weight	=	No
Soil Passive Resistance (for Sliding)	=	250.0 pcf
Soil/Concrete Friction Coeff.	=	0.30

#### Analysis Settings

Min Steel % Bending Reinf.	=	
Min Allow % Temp Reinf.	=	0.00180
Min. Overturning Safety Factor	=	1.0 : 1
Min. Sliding Safety Factor	=	1.0 : 1
Add Ftg Wt for Soil Pressure	:	Yes
Use ftg wt for stability, moments & shears	:	Yes
Add Pedestal Wt for Soil Pressure	:	Yes
Use Pedestal wt for stability, mom & shear	:	Yes

#### Increases based on footing Depth

Footing base depth below soil surface	=	ft
Allow press. increase per foot of depth when footing base is below	=	ksf
	=	ft

#### Increases based on footing plan dimension

Allowable pressure increase per foot of depth when max. length or width is greater than	=	ksf
	=	ft

### Dimensions

Width parallel to X-X Axis	=	2.0 ft
Length parallel to Z-Z Axis	=	2.0 ft
Footing Thickness	=	8.0 in

Pedestal dimensions...	=	
px : parallel to X-X Axis	=	6.0 in
pz : parallel to Z-Z Axis	=	6 in
Height	=	24.0 in
Rebar Centerline to Edge of Concrete... at Bottom of footing	=	3.250 in

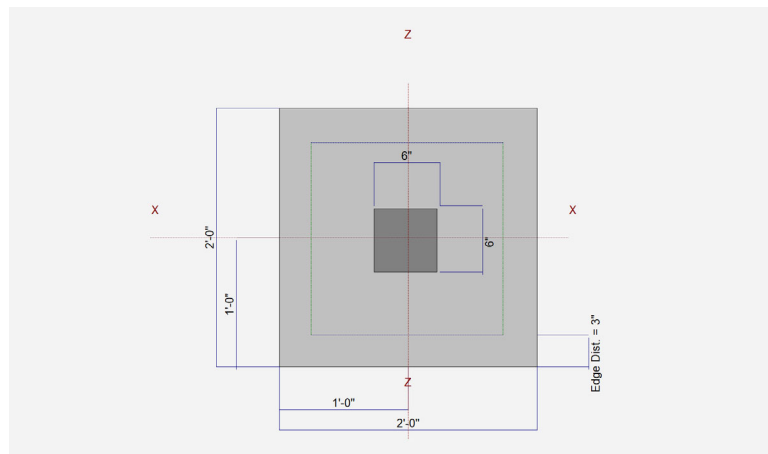

### Reinforcing

Bars parallel to X-X Axis	=	
Number of Bars	=	2.0
Reinforcing Bar Size	=	# 4
Bars parallel to Z-Z Axis	=	
Number of Bars	=	2.0
Reinforcing Bar Size	=	# 4
Bandwidth Distribution Check (ACI 15.4.4.2)		
Direction Requiring Closer Separation		n/a
# Bars required within zone		n/a
# Bars required on each side of zone		n/a

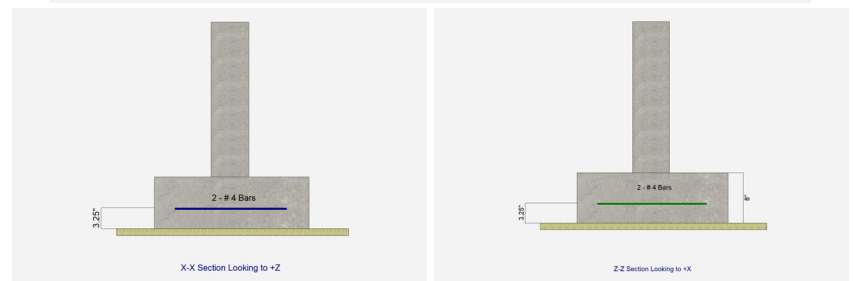

### Applied Loads

	D	Lr	L	S	W	E	H		
P : Column Load	=	5.30							k
OB : Overburden	=	0.040							ksf
M-xx	=								k-ft
M-zz	=								k-ft
V-x	=								k
V-z	=								k



**General Footing**

Lic. # : KW-06007473

Licensee : SHAWN REEDER

Description : 24"x24"x8" Pad Footing

**DESIGN SUMMARY**

**Design OK**

	Min. Ratio	Item	Applied	Capacity	Governing Load Combination
PASS	0.9847	Soil Bearing	1.477 ksf	1.50 ksf	+D+0.750L+0.750S+0.5250E+H about Z-
PASS	n/a	Overturing - X-X	0.0 k-ft	0.0 k-ft	No Overturing
PASS	n/a	Overturing - Z-Z	0.0 k-ft	0.0 k-ft	No Overturing
PASS	n/a	Sliding - X-X	0.0 k	0.0 k	No Sliding
PASS	n/a	Sliding - Z-Z	0.0 k	0.0 k	No Sliding
PASS	n/a	Uplift	0.0 k	0.0 k	No Uplift
PASS	0.1299	Z Flexure (+X)	0.5278 k-ft/ft	4.063 k-ft/ft	+1.40D+1.60H
PASS	0.1299	Z Flexure (-X)	0.5278 k-ft/ft	4.063 k-ft/ft	+1.40D+1.60H
PASS	0.1299	X Flexure (+Z)	0.5278 k-ft/ft	4.063 k-ft/ft	+1.40D+1.60H
PASS	0.1299	X Flexure (-Z)	0.5278 k-ft/ft	4.063 k-ft/ft	+1.40D+1.60H
PASS	0.1581	1-way Shear (+X)	11.854 psi	75.0 psi	+1.40D+1.60H
PASS	0.1581	1-way Shear (-X)	11.854 psi	75.0 psi	+1.40D+1.60H
PASS	0.1581	1-way Shear (+Z)	11.854 psi	75.0 psi	+1.40D+1.60H
PASS	0.1581	1-way Shear (-Z)	11.854 psi	75.0 psi	+1.40D+1.60H
PASS	0.1976	2-way Punching	29.640 psi	150.0 psi	+1.40D+1.60H

**Detailed Results**

**Soil Bearing**

Rotation Axis & Load Combination...	Gross Allowable	Xecc	Zecc (in)	Actual Soil Bearing Stress @ Location				Actual / Allow Ratio
				Bottom, -Z	Top, +Z	Left, -X	Right, +X	
X-X, +D+H	1.50	n/a	0.0	1.477	1.477	n/a	n/a	0.985
X-X, +D+L+H	1.50	n/a	0.0	1.477	1.477	n/a	n/a	0.985
X-X, +D+Lr+H	1.50	n/a	0.0	1.477	1.477	n/a	n/a	0.985
X-X, +D+S+H	1.50	n/a	0.0	1.477	1.477	n/a	n/a	0.985
X-X, +D+0.750Lr+0.750L+H	1.50	n/a	0.0	1.477	1.477	n/a	n/a	0.985
X-X, +D+0.750L+0.750S+H	1.50	n/a	0.0	1.477	1.477	n/a	n/a	0.985
X-X, +D+0.60W+H	1.50	n/a	0.0	1.477	1.477	n/a	n/a	0.985
X-X, +D+0.70E+H	1.50	n/a	0.0	1.477	1.477	n/a	n/a	0.985
X-X, +D+0.750Lr+0.750L+0.450W+H	1.50	n/a	0.0	1.477	1.477	n/a	n/a	0.985
X-X, +D+0.750L+0.750S+0.450W+H	1.50	n/a	0.0	1.477	1.477	n/a	n/a	0.985
X-X, +D+0.750L+0.750S+0.5250E+H	1.50	n/a	0.0	1.477	1.477	n/a	n/a	0.985
X-X, +0.60D+0.60W+0.60H	1.50	n/a	0.0	0.8864	0.8864	n/a	n/a	0.591
X-X, +0.60D+0.70E+0.60H	1.50	n/a	0.0	0.8864	0.8864	n/a	n/a	0.591
Z-Z, +D+H	1.50	0.0	n/a	n/a	n/a	1.477	1.477	0.985
Z-Z, +D+L+H	1.50	0.0	n/a	n/a	n/a	1.477	1.477	0.985
Z-Z, +D+Lr+H	1.50	0.0	n/a	n/a	n/a	1.477	1.477	0.985
Z-Z, +D+S+H	1.50	0.0	n/a	n/a	n/a	1.477	1.477	0.985
Z-Z, +D+0.750Lr+0.750L+H	1.50	0.0	n/a	n/a	n/a	1.477	1.477	0.985
Z-Z, +D+0.750L+0.750S+H	1.50	0.0	n/a	n/a	n/a	1.477	1.477	0.985
Z-Z, +D+0.60W+H	1.50	0.0	n/a	n/a	n/a	1.477	1.477	0.985
Z-Z, +D+0.70E+H	1.50	0.0	n/a	n/a	n/a	1.477	1.477	0.985
Z-Z, +D+0.750Lr+0.750L+0.450W+H	1.50	0.0	n/a	n/a	n/a	1.477	1.477	0.985
Z-Z, +D+0.750L+0.750S+0.450W+H	1.50	0.0	n/a	n/a	n/a	1.477	1.477	0.985
Z-Z, +D+0.750L+0.750S+0.5250E+H	1.50	0.0	n/a	n/a	n/a	1.477	1.477	0.985
Z-Z, +0.60D+0.60W+0.60H	1.50	0.0	n/a	n/a	n/a	0.8864	0.8864	0.591
Z-Z, +0.60D+0.70E+0.60H	1.50	0.0	n/a	n/a	n/a	0.8864	0.8864	0.591

**Overturing Stability**

Rotation Axis & Load Combination...	Overturing Moment	Resisting Moment	Stability Ratio	Status
Footing Has NO Overturing				

**Sliding Stability**

All units k

Force Application Axis Load Combination...	Sliding Force	Resisting Force	Stability Ratio	Status
Footing Has NO Sliding				



Performance Engineers  
1102 N. Franklin Blvd  
Nampa, ID 83687

Project Title:  
Engineer:  
Project ID:  
Project Descr:

**General Footing**

File = U:\Desktop\Folders\2018-0\CALCUL-107 Foundation.ec6  
Software copyright ENERCALC, INC. 1983-2018, Build:10.18.11.30

Lic. # : KW-06007473

Licensee : SHAWN REEDER

Description : 24"x24"x8" Pad Footing

**Footing Flexure**

Flexure Axis & Load Combination	Mu k-ft	Side	Tension Surface	As Req'd in^2	Gvrn. As in^2	Actual As in^2	Phi*Mn k-ft	Status
X-X, +1.40D+1.60H	0.5278	+Z	Bottom	0.1728	Min Temp %	0.20	4.063	OK
X-X, +1.40D+1.60H	0.5278	-Z	Bottom	0.1728	Min Temp %	0.20	4.063	OK
X-X, +1.20D+0.50Lr+1.60L+1.60H	0.4524	+Z	Bottom	0.1728	Min Temp %	0.20	4.063	OK
X-X, +1.20D+0.50Lr+1.60L+1.60H	0.4524	-Z	Bottom	0.1728	Min Temp %	0.20	4.063	OK
X-X, +1.20D+1.60L+0.50S+1.60H	0.4524	+Z	Bottom	0.1728	Min Temp %	0.20	4.063	OK
X-X, +1.20D+1.60L+0.50S+1.60H	0.4524	-Z	Bottom	0.1728	Min Temp %	0.20	4.063	OK
X-X, +1.20D+1.60Lr+0.50L+1.60H	0.4524	+Z	Bottom	0.1728	Min Temp %	0.20	4.063	OK
X-X, +1.20D+1.60Lr+0.50L+1.60H	0.4524	-Z	Bottom	0.1728	Min Temp %	0.20	4.063	OK
X-X, +1.20D+1.60Lr+0.50W+1.60H	0.4524	+Z	Bottom	0.1728	Min Temp %	0.20	4.063	OK
X-X, +1.20D+1.60Lr+0.50W+1.60H	0.4524	-Z	Bottom	0.1728	Min Temp %	0.20	4.063	OK
X-X, +1.20D+0.50L+1.60S+1.60H	0.4524	+Z	Bottom	0.1728	Min Temp %	0.20	4.063	OK
X-X, +1.20D+0.50L+1.60S+1.60H	0.4524	-Z	Bottom	0.1728	Min Temp %	0.20	4.063	OK
X-X, +1.20D+1.60S+0.50W+1.60H	0.4524	+Z	Bottom	0.1728	Min Temp %	0.20	4.063	OK
X-X, +1.20D+1.60S+0.50W+1.60H	0.4524	-Z	Bottom	0.1728	Min Temp %	0.20	4.063	OK
X-X, +1.20D+0.50Lr+0.50L+W+1.60H	0.4524	+Z	Bottom	0.1728	Min Temp %	0.20	4.063	OK
X-X, +1.20D+0.50Lr+0.50L+W+1.60H	0.4524	-Z	Bottom	0.1728	Min Temp %	0.20	4.063	OK
X-X, +1.20D+0.50L+0.50S+W+1.60H	0.4524	+Z	Bottom	0.1728	Min Temp %	0.20	4.063	OK
X-X, +1.20D+0.50L+0.50S+W+1.60H	0.4524	-Z	Bottom	0.1728	Min Temp %	0.20	4.063	OK
X-X, +1.20D+0.50L+0.70S+E+1.60H	0.4524	+Z	Bottom	0.1728	Min Temp %	0.20	4.063	OK
X-X, +1.20D+0.50L+0.70S+E+1.60H	0.4524	-Z	Bottom	0.1728	Min Temp %	0.20	4.063	OK
X-X, +0.90D+W+0.90H	0.3393	+Z	Bottom	0.1728	Min Temp %	0.20	4.063	OK
X-X, +0.90D+W+0.90H	0.3393	-Z	Bottom	0.1728	Min Temp %	0.20	4.063	OK
X-X, +0.90D+E+0.90H	0.3393	+Z	Bottom	0.1728	Min Temp %	0.20	4.063	OK
X-X, +0.90D+E+0.90H	0.3393	-Z	Bottom	0.1728	Min Temp %	0.20	4.063	OK
Z-Z, +1.40D+1.60H	0.5278	-X	Bottom	0.1728	Min Temp %	0.20	4.063	OK
Z-Z, +1.40D+1.60H	0.5278	+X	Bottom	0.1728	Min Temp %	0.20	4.063	OK
Z-Z, +1.20D+0.50Lr+1.60L+1.60H	0.4524	-X	Bottom	0.1728	Min Temp %	0.20	4.063	OK
Z-Z, +1.20D+0.50Lr+1.60L+1.60H	0.4524	+X	Bottom	0.1728	Min Temp %	0.20	4.063	OK
Z-Z, +1.20D+1.60L+0.50S+1.60H	0.4524	-X	Bottom	0.1728	Min Temp %	0.20	4.063	OK
Z-Z, +1.20D+1.60L+0.50S+1.60H	0.4524	+X	Bottom	0.1728	Min Temp %	0.20	4.063	OK
Z-Z, +1.20D+1.60Lr+0.50L+1.60H	0.4524	-X	Bottom	0.1728	Min Temp %	0.20	4.063	OK
Z-Z, +1.20D+1.60Lr+0.50L+1.60H	0.4524	+X	Bottom	0.1728	Min Temp %	0.20	4.063	OK
Z-Z, +1.20D+1.60Lr+0.50W+1.60H	0.4524	-X	Bottom	0.1728	Min Temp %	0.20	4.063	OK
Z-Z, +1.20D+1.60Lr+0.50W+1.60H	0.4524	+X	Bottom	0.1728	Min Temp %	0.20	4.063	OK
Z-Z, +1.20D+0.50L+1.60S+1.60H	0.4524	-X	Bottom	0.1728	Min Temp %	0.20	4.063	OK
Z-Z, +1.20D+0.50L+1.60S+1.60H	0.4524	+X	Bottom	0.1728	Min Temp %	0.20	4.063	OK
Z-Z, +1.20D+1.60S+0.50W+1.60H	0.4524	-X	Bottom	0.1728	Min Temp %	0.20	4.063	OK
Z-Z, +1.20D+1.60S+0.50W+1.60H	0.4524	+X	Bottom	0.1728	Min Temp %	0.20	4.063	OK
Z-Z, +1.20D+0.50Lr+0.50L+W+1.60H	0.4524	-X	Bottom	0.1728	Min Temp %	0.20	4.063	OK
Z-Z, +1.20D+0.50Lr+0.50L+W+1.60H	0.4524	+X	Bottom	0.1728	Min Temp %	0.20	4.063	OK
Z-Z, +1.20D+0.50L+0.50S+W+1.60H	0.4524	-X	Bottom	0.1728	Min Temp %	0.20	4.063	OK
Z-Z, +1.20D+0.50L+0.50S+W+1.60H	0.4524	+X	Bottom	0.1728	Min Temp %	0.20	4.063	OK
Z-Z, +1.20D+0.50L+0.70S+E+1.60H	0.4524	-X	Bottom	0.1728	Min Temp %	0.20	4.063	OK
Z-Z, +1.20D+0.50L+0.70S+E+1.60H	0.4524	+X	Bottom	0.1728	Min Temp %	0.20	4.063	OK
Z-Z, +0.90D+W+0.90H	0.3393	-X	Bottom	0.1728	Min Temp %	0.20	4.063	OK
Z-Z, +0.90D+W+0.90H	0.3393	+X	Bottom	0.1728	Min Temp %	0.20	4.063	OK
Z-Z, +0.90D+E+0.90H	0.3393	-X	Bottom	0.1728	Min Temp %	0.20	4.063	OK
Z-Z, +0.90D+E+0.90H	0.3393	+X	Bottom	0.1728	Min Temp %	0.20	4.063	OK

**One Way Shear**

Load Combination...	Vu @ -X	Vu @ +X	Vu @ -Z	Vu @ +Z	Vu:Max	Phi Vn	Vu / Phi*Vn	Status
+1.40D+1.60H	11.85 psi	11.85 psi	11.85 psi	11.85 psi	11.85 psi	75.00 psi	0.16	OK
+1.20D+0.50Lr+1.60L+1.60H	10.16 psi	10.16 psi	10.16 psi	10.16 psi	10.16 psi	75.00 psi	0.14	OK
+1.20D+1.60L+0.50S+1.60H	10.16 psi	10.16 psi	10.16 psi	10.16 psi	10.16 psi	75.00 psi	0.14	OK
+1.20D+1.60Lr+0.50L+1.60H	10.16 psi	10.16 psi	10.16 psi	10.16 psi	10.16 psi	75.00 psi	0.14	OK
+1.20D+1.60Lr+0.50L+1.60H	10.16 psi	10.16 psi	10.16 psi	10.16 psi	10.16 psi	75.00 psi	0.14	OK
+1.20D+0.50L+1.60S+1.60H	10.16 psi	10.16 psi	10.16 psi	10.16 psi	10.16 psi	75.00 psi	0.14	OK
+1.20D+1.60S+0.50W+1.60H	10.16 psi	10.16 psi	10.16 psi	10.16 psi	10.16 psi	75.00 psi	0.14	OK
+1.20D+0.50Lr+0.50L+W+1.60H	10.16 psi	10.16 psi	10.16 psi	10.16 psi	10.16 psi	75.00 psi	0.14	OK
+1.20D+0.50L+0.50S+W+1.60H	10.16 psi	10.16 psi	10.16 psi	10.16 psi	10.16 psi	75.00 psi	0.14	OK
+1.20D+0.50L+0.70S+E+1.60H	10.16 psi	10.16 psi	10.16 psi	10.16 psi	10.16 psi	75.00 psi	0.14	OK
+0.90D+W+0.90H	7.62 psi	7.62 psi	7.62 psi	7.62 psi	7.62 psi	75.00 psi	0.10	OK



Performance Engineers  
 1102 N. Franklin Blvd  
 Nampa, ID 83687

Project Title:  
 Engineer:  
 Project ID:  
 Project Descr:

**General Footing**

File = U:\Desktop\Folders\2018-0\CALCUL-107 Foundation.ec6 .  
 Software copyright ENERCALC, INC. 1983-2018, Build:10.18.11.30 .

Lic. # : KW-06007473

Licensee : SHAWN REEDER

Description : 24"x24"x8" Pad Footing

**One Way Shear**

Load Combination...	Vu @ -X	Vu @ +X	Vu @ -Z	Vu @ +Z	Vu:Max	Phi Vn	Vu / Phi*Vn	Status
+0.90D+E+0.90H	7.62 psi	7.62 psi	7.62 psi	7.62 psi	7.62 psi	75.00 psi	0.10	OK
All units k								

**Two-Way "Punching" Shear**

Load Combination...	Vu	Phi*Vn	Vu / Phi*Vn	Status
+1.40D+1.60H	29.64 psi	150.00 psi	0.1976	OK
+1.20D+0.50Lr+1.60L+1.60H	25.41 psi	150.00 psi	0.1694	OK
+1.20D+1.60L+0.50S+1.60H	25.41 psi	150.00 psi	0.1694	OK
+1.20D+1.60Lr+0.50L+1.60H	25.41 psi	150.00 psi	0.1694	OK
+1.20D+1.60Lr+0.50W+1.60H	25.41 psi	150.00 psi	0.1694	OK
+1.20D+0.50L+1.60S+1.60H	25.41 psi	150.00 psi	0.1694	OK
+1.20D+1.60S+0.50W+1.60H	25.41 psi	150.00 psi	0.1694	OK
+1.20D+0.50Lr+0.50L+W+1.60H	25.41 psi	150.00 psi	0.1694	OK
+1.20D+0.50L+0.50S+W+1.60H	25.41 psi	150.00 psi	0.1694	OK
+1.20D+0.50L+0.70S+E+1.60H	25.41 psi	150.00 psi	0.1694	OK
+0.90D+W+0.90H	19.06 psi	150.00 psi	0.127	OK
+0.90D+E+0.90H	19.06 psi	150.00 psi	0.127	OK



## General Footing

File = U:\Desktop\Folders\2018-0\CALCUL-1107 Foundation.ec6 .  
Software copyright ENERCALC, INC. 1983-2018, Build:10.18.11.30 .

Lic. # : KW-06007473

Licensee : SHAWN REEDER

Description : 30"x30"x8" Pad Footing

### Code References

Calculations per ACI 318-14, IBC 2015, CBC 2016, ASCE 7-10

Load Combinations Used : IBC 2015

### General Information

#### Material Properties

$f_c$ : Concrete 28 day strength	=	2.50	ksi
$f_y$ : Rebar Yield	=	60.0	ksi
$E_c$ : Concrete Elastic Modulus	=	3,122.0	ksi
Concrete Density	=	145.0	pcf
$\phi$ Values Flexure	=	0.90	
Shear	=	0.750	

#### Soil Design Values

Allowable Soil Bearing	=	1.50	ksf
Increase Bearing By Footing Weight	=	No	
Soil Passive Resistance (for Sliding)	=	250.0	pcf
Soil/Concrete Friction Coeff.	=	0.30	

#### Analysis Settings

Min Steel % Bending Reinf.	=	
Min Allow % Temp Reinf.	=	0.00180
Min. Overturning Safety Factor	=	1.0 : 1
Min. Sliding Safety Factor	=	1.0 : 1
Add Ftg Wt for Soil Pressure	:	Yes
Use ftg wt for stability, moments & shears	:	Yes
Add Pedestal Wt for Soil Pressure	:	Yes
Use Pedestal wt for stability, mom & shear	:	Yes

#### Increases based on footing Depth

Footing base depth below soil surface	=		ft
Allow press. increase per foot of depth when footing base is below	=		ksf
	=		ft

#### Increases based on footing plan dimension

Allowable pressure increase per foot of depth when max. length or width is greater than	=		ksf
	=		ft

### Dimensions

Width parallel to X-X Axis	=	2.50	ft
Length parallel to Z-Z Axis	=	2.50	ft
Footing Thickness	=	8.0	in

Pedestal dimensions...	=		
px : parallel to X-X Axis	=	6.0	in
pz : parallel to Z-Z Axis	=	6	in
Height	=	24.0	in
Rebar Centerline to Edge of Concrete... at Bottom of footing	=	3.250	in

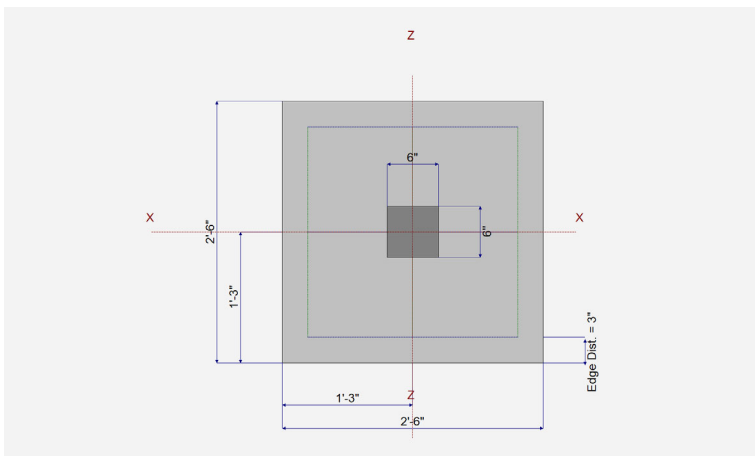

### Reinforcing

Bars parallel to X-X Axis	=	
Number of Bars	=	3.0
Reinforcing Bar Size	=	# 4
Bars parallel to Z-Z Axis	=	
Number of Bars	=	3.0
Reinforcing Bar Size	=	# 4
Bandwidth Distribution Check (ACI 15.4.4.2)		
Direction Requiring Closer Separation		n/a
# Bars required within zone		n/a
# Bars required on each side of zone		n/a

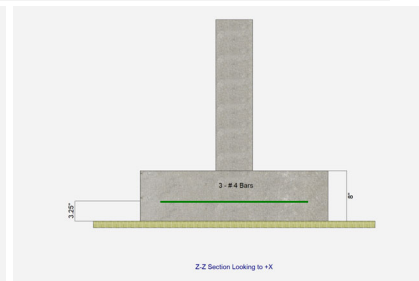
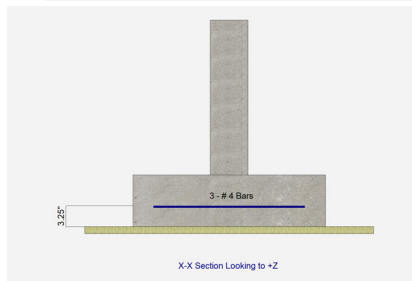

### Applied Loads

	D	Lr	L	S	W	E	H	
P : Column Load	=	8.350						k
OB : Overburden	=	0.040						ksf
M-xx	=							k-ft
M-zz	=							k-ft
V-x	=							k
V-z	=							k



**General Footing**

Lic. # : KW-06007473

Licensee : SHAWN REEDER

Description : 30"x30"x8" Pad Footing

**DESIGN SUMMARY**

**Design OK**

	Min. Ratio	Item	Applied	Capacity	Governing Load Combination
PASS	0.9887	Soil Bearing	1.483 ksf	1.50 ksf	+D+0.750L+0.750S+0.5250E+H about Z-
PASS	n/a	Overturing - X-X	0.0 k-ft	0.0 k-ft	No Overturing
PASS	n/a	Overturing - Z-Z	0.0 k-ft	0.0 k-ft	No Overturing
PASS	n/a	Sliding - X-X	0.0 k	0.0 k	No Sliding
PASS	n/a	Sliding - Z-Z	0.0 k	0.0 k	No Sliding
PASS	n/a	Uplift	0.0 k	0.0 k	No Uplift
PASS	0.1953	Z Flexure (+X)	0.9422 k-ft/ft	4.825 k-ft/ft	+1.40D+1.60H
PASS	0.1953	Z Flexure (-X)	0.9422 k-ft/ft	4.825 k-ft/ft	+1.40D+1.60H
PASS	0.1953	X Flexure (+Z)	0.9422 k-ft/ft	4.825 k-ft/ft	+1.40D+1.60H
PASS	0.1953	X Flexure (-Z)	0.9422 k-ft/ft	4.825 k-ft/ft	+1.40D+1.60H
PASS	0.2645	1-way Shear (+X)	19.836 psi	75.0 psi	+1.40D+1.60H
PASS	0.2645	1-way Shear (-X)	19.836 psi	75.0 psi	+1.40D+1.60H
PASS	0.2645	1-way Shear (+Z)	19.836 psi	75.0 psi	+1.40D+1.60H
PASS	0.2645	1-way Shear (-Z)	19.836 psi	75.0 psi	+1.40D+1.60H
PASS	0.3346	2-way Punching	50.189 psi	150.0 psi	+1.40D+1.60H

**Detailed Results**

**Soil Bearing**

Rotation Axis & Load Combination...	Gross Allowable	Xecc	Zecc (in)	Actual Soil Bearing Stress @ Location				Actual / Allow Ratio
				Bottom, -Z	Top, +Z	Left, -X	Right, +X	
X-X, +D+H	1.50	n/a	0.0	1.483	1.483	n/a	n/a	0.989
X-X, +D+L+H	1.50	n/a	0.0	1.483	1.483	n/a	n/a	0.989
X-X, +D+Lr+H	1.50	n/a	0.0	1.483	1.483	n/a	n/a	0.989
X-X, +D+S+H	1.50	n/a	0.0	1.483	1.483	n/a	n/a	0.989
X-X, +D+0.750Lr+0.750L+H	1.50	n/a	0.0	1.483	1.483	n/a	n/a	0.989
X-X, +D+0.750L+0.750S+H	1.50	n/a	0.0	1.483	1.483	n/a	n/a	0.989
X-X, +D+0.60W+H	1.50	n/a	0.0	1.483	1.483	n/a	n/a	0.989
X-X, +D+0.70E+H	1.50	n/a	0.0	1.483	1.483	n/a	n/a	0.989
X-X, +D+0.750Lr+0.750L+0.450W+H	1.50	n/a	0.0	1.483	1.483	n/a	n/a	0.989
X-X, +D+0.750L+0.750S+0.450W+H	1.50	n/a	0.0	1.483	1.483	n/a	n/a	0.989
X-X, +D+0.750L+0.750S+0.5250E+H	1.50	n/a	0.0	1.483	1.483	n/a	n/a	0.989
X-X, +0.60D+0.60W+0.60H	1.50	n/a	0.0	0.8896	0.8896	n/a	n/a	0.593
X-X, +0.60D+0.70E+0.60H	1.50	n/a	0.0	0.8896	0.8896	n/a	n/a	0.593
Z-Z, +D+H	1.50	0.0	n/a	n/a	n/a	1.483	1.483	0.989
Z-Z, +D+L+H	1.50	0.0	n/a	n/a	n/a	1.483	1.483	0.989
Z-Z, +D+Lr+H	1.50	0.0	n/a	n/a	n/a	1.483	1.483	0.989
Z-Z, +D+S+H	1.50	0.0	n/a	n/a	n/a	1.483	1.483	0.989
Z-Z, +D+0.750Lr+0.750L+H	1.50	0.0	n/a	n/a	n/a	1.483	1.483	0.989
Z-Z, +D+0.750L+0.750S+H	1.50	0.0	n/a	n/a	n/a	1.483	1.483	0.989
Z-Z, +D+0.60W+H	1.50	0.0	n/a	n/a	n/a	1.483	1.483	0.989
Z-Z, +D+0.70E+H	1.50	0.0	n/a	n/a	n/a	1.483	1.483	0.989
Z-Z, +D+0.750Lr+0.750L+0.450W+H	1.50	0.0	n/a	n/a	n/a	1.483	1.483	0.989
Z-Z, +D+0.750L+0.750S+0.450W+H	1.50	0.0	n/a	n/a	n/a	1.483	1.483	0.989
Z-Z, +D+0.750L+0.750S+0.5250E+H	1.50	0.0	n/a	n/a	n/a	1.483	1.483	0.989
Z-Z, +0.60D+0.60W+0.60H	1.50	0.0	n/a	n/a	n/a	0.8896	0.8896	0.593
Z-Z, +0.60D+0.70E+0.60H	1.50	0.0	n/a	n/a	n/a	0.8896	0.8896	0.593

**Overturing Stability**

Rotation Axis & Load Combination...	Overturing Moment	Resisting Moment	Stability Ratio	Status
Footing Has NO Overturing				

**Sliding Stability**

All units k

Force Application Axis Load Combination...	Sliding Force	Resisting Force	Stability Ratio	Status
Footing Has NO Sliding				



Performance Engineers  
1102 N. Franklin Blvd  
Nampa, ID 83687

Project Title:  
Engineer:  
Project ID:  
Project Descr:

**General Footing**

File = U:\Desktop\Folders\2018-0\CALCUL-107 Foundation.ec6  
Software copyright ENERCALC, INC. 1983-2018, Build:10.18.11.30

Lic. # : KW-06007473

Licensee : SHAWN REEDER

Description : 30"x30"x8" Pad Footing

**Footing Flexure**

Flexure Axis & Load Combination	Mu k-ft	Side	Tension Surface	As Req'd in^2	Gvrn. As in^2	Actual As in^2	Phi*Mn k-ft	Status
X-X, +1.40D+1.60H	0.9422	+Z	Bottom	0.1728	Min Temp %	0.240	4.825	OK
X-X, +1.40D+1.60H	0.9422	-Z	Bottom	0.1728	Min Temp %	0.240	4.825	OK
X-X, +1.20D+0.50Lr+1.60L+1.60H	0.8076	+Z	Bottom	0.1728	Min Temp %	0.240	4.825	OK
X-X, +1.20D+0.50Lr+1.60L+1.60H	0.8076	-Z	Bottom	0.1728	Min Temp %	0.240	4.825	OK
X-X, +1.20D+1.60L+0.50S+1.60H	0.8076	+Z	Bottom	0.1728	Min Temp %	0.240	4.825	OK
X-X, +1.20D+1.60L+0.50S+1.60H	0.8076	-Z	Bottom	0.1728	Min Temp %	0.240	4.825	OK
X-X, +1.20D+1.60Lr+0.50L+1.60H	0.8076	+Z	Bottom	0.1728	Min Temp %	0.240	4.825	OK
X-X, +1.20D+1.60Lr+0.50L+1.60H	0.8076	-Z	Bottom	0.1728	Min Temp %	0.240	4.825	OK
X-X, +1.20D+1.60Lr+0.50W+1.60H	0.8076	+Z	Bottom	0.1728	Min Temp %	0.240	4.825	OK
X-X, +1.20D+1.60Lr+0.50W+1.60H	0.8076	-Z	Bottom	0.1728	Min Temp %	0.240	4.825	OK
X-X, +1.20D+0.50L+1.60S+1.60H	0.8076	+Z	Bottom	0.1728	Min Temp %	0.240	4.825	OK
X-X, +1.20D+0.50L+1.60S+1.60H	0.8076	-Z	Bottom	0.1728	Min Temp %	0.240	4.825	OK
X-X, +1.20D+1.60S+0.50W+1.60H	0.8076	+Z	Bottom	0.1728	Min Temp %	0.240	4.825	OK
X-X, +1.20D+1.60S+0.50W+1.60H	0.8076	-Z	Bottom	0.1728	Min Temp %	0.240	4.825	OK
X-X, +1.20D+0.50Lr+0.50L+W+1.60H	0.8076	+Z	Bottom	0.1728	Min Temp %	0.240	4.825	OK
X-X, +1.20D+0.50Lr+0.50L+W+1.60H	0.8076	-Z	Bottom	0.1728	Min Temp %	0.240	4.825	OK
X-X, +1.20D+0.50L+0.50S+W+1.60H	0.8076	+Z	Bottom	0.1728	Min Temp %	0.240	4.825	OK
X-X, +1.20D+0.50L+0.50S+W+1.60H	0.8076	-Z	Bottom	0.1728	Min Temp %	0.240	4.825	OK
X-X, +1.20D+0.50L+0.70S+E+1.60H	0.8076	+Z	Bottom	0.1728	Min Temp %	0.240	4.825	OK
X-X, +1.20D+0.50L+0.70S+E+1.60H	0.8076	-Z	Bottom	0.1728	Min Temp %	0.240	4.825	OK
X-X, +0.90D+W+0.90H	0.6057	+Z	Bottom	0.1728	Min Temp %	0.240	4.825	OK
X-X, +0.90D+W+0.90H	0.6057	-Z	Bottom	0.1728	Min Temp %	0.240	4.825	OK
X-X, +0.90D+E+0.90H	0.6057	+Z	Bottom	0.1728	Min Temp %	0.240	4.825	OK
X-X, +0.90D+E+0.90H	0.6057	-Z	Bottom	0.1728	Min Temp %	0.240	4.825	OK
Z-Z, +1.40D+1.60H	0.9422	-X	Bottom	0.1728	Min Temp %	0.240	4.825	OK
Z-Z, +1.40D+1.60H	0.9422	+X	Bottom	0.1728	Min Temp %	0.240	4.825	OK
Z-Z, +1.20D+0.50Lr+1.60L+1.60H	0.8076	-X	Bottom	0.1728	Min Temp %	0.240	4.825	OK
Z-Z, +1.20D+0.50Lr+1.60L+1.60H	0.8076	+X	Bottom	0.1728	Min Temp %	0.240	4.825	OK
Z-Z, +1.20D+1.60L+0.50S+1.60H	0.8076	-X	Bottom	0.1728	Min Temp %	0.240	4.825	OK
Z-Z, +1.20D+1.60L+0.50S+1.60H	0.8076	+X	Bottom	0.1728	Min Temp %	0.240	4.825	OK
Z-Z, +1.20D+1.60Lr+0.50L+1.60H	0.8076	-X	Bottom	0.1728	Min Temp %	0.240	4.825	OK
Z-Z, +1.20D+1.60Lr+0.50L+1.60H	0.8076	+X	Bottom	0.1728	Min Temp %	0.240	4.825	OK
Z-Z, +1.20D+1.60Lr+0.50W+1.60H	0.8076	-X	Bottom	0.1728	Min Temp %	0.240	4.825	OK
Z-Z, +1.20D+1.60Lr+0.50W+1.60H	0.8076	+X	Bottom	0.1728	Min Temp %	0.240	4.825	OK
Z-Z, +1.20D+0.50L+1.60S+1.60H	0.8076	-X	Bottom	0.1728	Min Temp %	0.240	4.825	OK
Z-Z, +1.20D+0.50L+1.60S+1.60H	0.8076	+X	Bottom	0.1728	Min Temp %	0.240	4.825	OK
Z-Z, +1.20D+1.60S+0.50W+1.60H	0.8076	-X	Bottom	0.1728	Min Temp %	0.240	4.825	OK
Z-Z, +1.20D+1.60S+0.50W+1.60H	0.8076	+X	Bottom	0.1728	Min Temp %	0.240	4.825	OK
Z-Z, +1.20D+0.50Lr+0.50L+W+1.60H	0.8076	-X	Bottom	0.1728	Min Temp %	0.240	4.825	OK
Z-Z, +1.20D+0.50Lr+0.50L+W+1.60H	0.8076	+X	Bottom	0.1728	Min Temp %	0.240	4.825	OK
Z-Z, +1.20D+0.50L+0.50S+W+1.60H	0.8076	-X	Bottom	0.1728	Min Temp %	0.240	4.825	OK
Z-Z, +1.20D+0.50L+0.50S+W+1.60H	0.8076	+X	Bottom	0.1728	Min Temp %	0.240	4.825	OK
Z-Z, +1.20D+0.50L+0.70S+E+1.60H	0.8076	-X	Bottom	0.1728	Min Temp %	0.240	4.825	OK
Z-Z, +1.20D+0.50L+0.70S+E+1.60H	0.8076	+X	Bottom	0.1728	Min Temp %	0.240	4.825	OK
Z-Z, +0.90D+W+0.90H	0.6057	-X	Bottom	0.1728	Min Temp %	0.240	4.825	OK
Z-Z, +0.90D+W+0.90H	0.6057	+X	Bottom	0.1728	Min Temp %	0.240	4.825	OK
Z-Z, +0.90D+E+0.90H	0.6057	-X	Bottom	0.1728	Min Temp %	0.240	4.825	OK
Z-Z, +0.90D+E+0.90H	0.6057	+X	Bottom	0.1728	Min Temp %	0.240	4.825	OK

**One Way Shear**

Load Combination...	Vu @ -X	Vu @ +X	Vu @ -Z	Vu @ +Z	Vu:Max	Phi Vn	Vu / Phi*Vn	Status
+1.40D+1.60H	19.84 psi	19.84 psi	19.84 psi	19.84 psi	19.84 psi	75.00 psi	0.26	OK
+1.20D+0.50Lr+1.60L+1.60H	17.00 psi	17.00 psi	17.00 psi	17.00 psi	17.00 psi	75.00 psi	0.23	OK
+1.20D+1.60L+0.50S+1.60H	17.00 psi	17.00 psi	17.00 psi	17.00 psi	17.00 psi	75.00 psi	0.23	OK
+1.20D+1.60Lr+0.50L+1.60H	17.00 psi	17.00 psi	17.00 psi	17.00 psi	17.00 psi	75.00 psi	0.23	OK
+1.20D+1.60Lr+0.50L+1.60H	17.00 psi	17.00 psi	17.00 psi	17.00 psi	17.00 psi	75.00 psi	0.23	OK
+1.20D+0.50L+1.60S+1.60H	17.00 psi	17.00 psi	17.00 psi	17.00 psi	17.00 psi	75.00 psi	0.23	OK
+1.20D+0.50L+1.60S+1.60H	17.00 psi	17.00 psi	17.00 psi	17.00 psi	17.00 psi	75.00 psi	0.23	OK
+1.20D+0.50Lr+0.50L+W+1.60H	17.00 psi	17.00 psi	17.00 psi	17.00 psi	17.00 psi	75.00 psi	0.23	OK
+1.20D+0.50L+0.50S+W+1.60H	17.00 psi	17.00 psi	17.00 psi	17.00 psi	17.00 psi	75.00 psi	0.23	OK
+1.20D+0.50L+0.50S+W+1.60H	17.00 psi	17.00 psi	17.00 psi	17.00 psi	17.00 psi	75.00 psi	0.23	OK
+1.20D+0.50L+0.70S+E+1.60H	17.00 psi	17.00 psi	17.00 psi	17.00 psi	17.00 psi	75.00 psi	0.23	OK
+0.90D+W+0.90H	12.75 psi	12.75 psi	12.75 psi	12.75 psi	12.75 psi	75.00 psi	0.17	OK



Performance Engineers  
 1102 N. Franklin Blvd  
 Nampa, ID 83687

Project Title:  
 Engineer:  
 Project ID:  
 Project Descr:

**General Footing**

File = U:\Desktop\Folders\2018-0\CALCUL-107 Foundation.ec6 .  
 Software copyright ENERCALC, INC. 1983-2018, Build:10.18.11.30 .

Lic. # : KW-06007473

Licensee : SHAWN REEDER

Description : 30"x30"x8" Pad Footing

**One Way Shear**

Load Combination...	Vu @ -X	Vu @ +X	Vu @ -Z	Vu @ +Z	Vu:Max	Phi Vn	Vu / Phi*Vn	Status
+0.90D+E+0.90H	12.75 psi	12.75 psi	12.75 psi	12.75 psi	12.75 psi	75.00 psi	0.17	OK
All units k								

**Two-Way "Punching" Shear**

Load Combination...	Vu	Phi*Vn	Vu / Phi*Vn	Status
+1.40D+1.60H	50.19 psi	150.00 psi	0.3346	OK
+1.20D+0.50Lr+1.60L+1.60H	43.02 psi	150.00 psi	0.2868	OK
+1.20D+1.60L+0.50S+1.60H	43.02 psi	150.00 psi	0.2868	OK
+1.20D+1.60Lr+0.50L+1.60H	43.02 psi	150.00 psi	0.2868	OK
+1.20D+1.60Lr+0.50W+1.60H	43.02 psi	150.00 psi	0.2868	OK
+1.20D+0.50L+1.60S+1.60H	43.02 psi	150.00 psi	0.2868	OK
+1.20D+1.60S+0.50W+1.60H	43.02 psi	150.00 psi	0.2868	OK
+1.20D+0.50Lr+0.50L+W+1.60H	43.02 psi	150.00 psi	0.2868	OK
+1.20D+0.50L+0.50S+W+1.60H	43.02 psi	150.00 psi	0.2868	OK
+1.20D+0.50L+0.70S+E+1.60H	43.02 psi	150.00 psi	0.2868	OK
+0.90D+W+0.90H	32.26 psi	150.00 psi	0.2151	OK
+0.90D+E+0.90H	32.26 psi	150.00 psi	0.2151	OK



**General Footing**

Lic. # : KW-06007473

Licensee : SHAWN REEDER

Description : 36"x36"x8" Pad Footing

**Code References**

Calculations per ACI 318-14, IBC 2015, CBC 2016, ASCE 7-10  
Load Combinations Used : IBC 2015

**General Information**

**Material Properties**

fc : Concrete 28 day strength	=	2.50	ksi
fy : Rebar Yield	=	60.0	ksi
Ec : Concrete Elastic Modulus	=	3,122.0	ksi
Concrete Density	=	145.0	pcf
φ Values Flexure	=	0.90	
Shear	=	0.750	

**Soil Design Values**

Allowable Soil Bearing	=	1.50	ksf
Increase Bearing By Footing Weight	=	No	
Soil Passive Resistance (for Sliding)	=	250.0	pcf
Soil/Concrete Friction Coeff.	=	0.30	

**Analysis Settings**

Min Steel % Bending Reinf.	=		
Min Allow % Temp Reinf.	=	0.00180	
Min. Overturning Safety Factor	=	1.0	: 1
Min. Sliding Safety Factor	=	1.0	: 1
Add Ftg Wt for Soil Pressure	:	Yes	
Use ftg wt for stability, moments & shears	:	Yes	
Add Pedestal Wt for Soil Pressure	:	Yes	
Use Pedestal wt for stability, mom & shear	:	Yes	

**Increases based on footing Depth**

Footing base depth below soil surface	=		ft
Allow press. increase per foot of depth when footing base is below	=		ksf
	=		ft

**Increases based on footing plan dimension**

Allowable pressure increase per foot of depth when max. length or width is greater than	=		ksf
	=		ft

**Dimensions**

Width parallel to X-X Axis	=	3.0	ft
Length parallel to Z-Z Axis	=	3.0	ft
Footing Thickness	=	8.0	in
Pedestal dimensions...			
px : parallel to X-X Axis	=	6.0	in
pz : parallel to Z-Z Axis	=	6	in
Height	=	24.0	in
Rebar Centerline to Edge of Concrete... at Bottom of footing	=	3.250	in

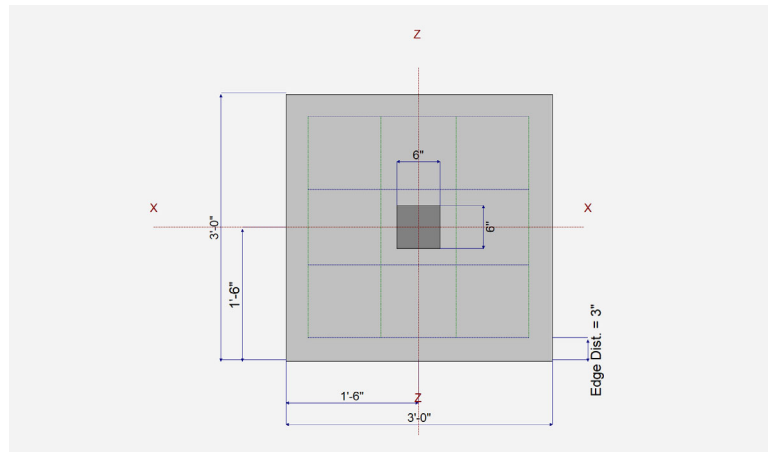

**Reinforcing**

Bars parallel to X-X Axis	=		
Number of Bars	=	4.0	
Reinforcing Bar Size	=	# 4	
Bars parallel to Z-Z Axis	=		
Number of Bars	=	4.0	
Reinforcing Bar Size	=	# 4	
Bandwidth Distribution Check (ACI 15.4.4.2)			
Direction Requiring Closer Separation		n/a	
# Bars required within zone		n/a	
# Bars required on each side of zone		n/a	

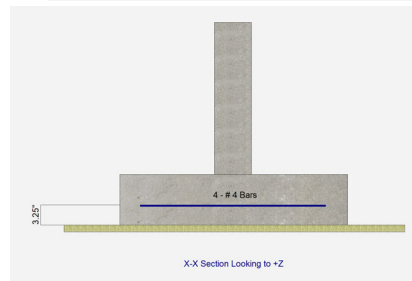

**Applied Loads**

	D	Lr	L	S	W	E	H	
P : Column Load	=	12.0						k
OB : Overburden	=	0.040						ksf
M-xx	=							k-ft
M-zz	=							k-ft
V-x	=							k
V-z	=							k



**General Footing**

Lic. # : KW-06007473

Licensee : SHAWN REEDER

Description : 36"x36"x8" Pad Footing

**DESIGN SUMMARY**

**Design OK**

	Min. Ratio	Item	Applied	Capacity	Governing Load Combination
PASS	0.9847	Soil Bearing	1.477 ksf	1.50 ksf	+D+0.750L+0.750S+0.5250E+H about Z-
PASS	n/a	Overturing - X-X	0.0 k-ft	0.0 k-ft	No Overturing
PASS	n/a	Overturing - Z-Z	0.0 k-ft	0.0 k-ft	No Overturing
PASS	n/a	Sliding - X-X	0.0 k	0.0 k	No Sliding
PASS	n/a	Sliding - Z-Z	0.0 k	0.0 k	No Sliding
PASS	n/a	Uplift	0.0 k	0.0 k	No Uplift
PASS	0.2754	Z Flexure (+X)	1.466 k-ft/ft	5.324 k-ft/ft	+1.40D+1.60H
PASS	0.2754	Z Flexure (-X)	1.466 k-ft/ft	5.324 k-ft/ft	+1.40D+1.60H
PASS	0.2754	X Flexure (+Z)	1.466 k-ft/ft	5.324 k-ft/ft	+1.40D+1.60H
PASS	0.2754	X Flexure (-Z)	1.466 k-ft/ft	5.324 k-ft/ft	+1.40D+1.60H
PASS	0.3687	1-way Shear (+X)	27.652 psi	75.0 psi	+1.40D+1.60H
PASS	0.3687	1-way Shear (-X)	27.652 psi	75.0 psi	+1.40D+1.60H
PASS	0.3687	1-way Shear (+Z)	27.652 psi	75.0 psi	+1.40D+1.60H
PASS	0.3687	1-way Shear (-Z)	27.652 psi	75.0 psi	+1.40D+1.60H
PASS	0.5016	2-way Punching	75.239 psi	150.0 psi	+1.40D+1.60H

**Detailed Results**

**Soil Bearing**

Rotation Axis & Load Combination...	Gross Allowable	Xecc	Zecc (in)	Actual Soil Bearing Stress @ Location				Actual / Allow Ratio
				Bottom, -Z	Top, +Z	Left, -X	Right, +X	
X-X, +D+H	1.50	n/a	0.0	1.477	1.477	n/a	n/a	0.985
X-X, +D+L+H	1.50	n/a	0.0	1.477	1.477	n/a	n/a	0.985
X-X, +D+Lr+H	1.50	n/a	0.0	1.477	1.477	n/a	n/a	0.985
X-X, +D+S+H	1.50	n/a	0.0	1.477	1.477	n/a	n/a	0.985
X-X, +D+0.750Lr+0.750L+H	1.50	n/a	0.0	1.477	1.477	n/a	n/a	0.985
X-X, +D+0.750L+0.750S+H	1.50	n/a	0.0	1.477	1.477	n/a	n/a	0.985
X-X, +D+0.60W+H	1.50	n/a	0.0	1.477	1.477	n/a	n/a	0.985
X-X, +D+0.70E+H	1.50	n/a	0.0	1.477	1.477	n/a	n/a	0.985
X-X, +D+0.750Lr+0.750L+0.450W+H	1.50	n/a	0.0	1.477	1.477	n/a	n/a	0.985
X-X, +D+0.750L+0.750S+0.450W+H	1.50	n/a	0.0	1.477	1.477	n/a	n/a	0.985
X-X, +D+0.750L+0.750S+0.5250E+H	1.50	n/a	0.0	1.477	1.477	n/a	n/a	0.985
X-X, +0.60D+0.60W+0.60H	1.50	n/a	0.0	0.8862	0.8862	n/a	n/a	0.591
X-X, +0.60D+0.70E+0.60H	1.50	n/a	0.0	0.8862	0.8862	n/a	n/a	0.591
Z-Z, +D+H	1.50	0.0	n/a	n/a	n/a	1.477	1.477	0.985
Z-Z, +D+L+H	1.50	0.0	n/a	n/a	n/a	1.477	1.477	0.985
Z-Z, +D+Lr+H	1.50	0.0	n/a	n/a	n/a	1.477	1.477	0.985
Z-Z, +D+S+H	1.50	0.0	n/a	n/a	n/a	1.477	1.477	0.985
Z-Z, +D+0.750Lr+0.750L+H	1.50	0.0	n/a	n/a	n/a	1.477	1.477	0.985
Z-Z, +D+0.750L+0.750S+H	1.50	0.0	n/a	n/a	n/a	1.477	1.477	0.985
Z-Z, +D+0.60W+H	1.50	0.0	n/a	n/a	n/a	1.477	1.477	0.985
Z-Z, +D+0.70E+H	1.50	0.0	n/a	n/a	n/a	1.477	1.477	0.985
Z-Z, +D+0.750Lr+0.750L+0.450W+H	1.50	0.0	n/a	n/a	n/a	1.477	1.477	0.985
Z-Z, +D+0.750L+0.750S+0.450W+H	1.50	0.0	n/a	n/a	n/a	1.477	1.477	0.985
Z-Z, +D+0.750L+0.750S+0.5250E+H	1.50	0.0	n/a	n/a	n/a	1.477	1.477	0.985
Z-Z, +0.60D+0.60W+0.60H	1.50	0.0	n/a	n/a	n/a	0.8862	0.8862	0.591
Z-Z, +0.60D+0.70E+0.60H	1.50	0.0	n/a	n/a	n/a	0.8862	0.8862	0.591

**Overturing Stability**

Rotation Axis & Load Combination...	Overturing Moment	Resisting Moment	Stability Ratio	Status
Footing Has NO Overturing				

**Sliding Stability**

All units k

Force Application Axis Load Combination...	Sliding Force	Resisting Force	Stability Ratio	Status
Footing Has NO Sliding				



Performance Engineers  
1102 N. Franklin Blvd  
Nampa, ID 83687

Project Title:  
Engineer:  
Project ID:  
Project Descr:

**General Footing**

File = U:\Desktop\Folders\2018-0\CALCUL-1107 Foundation.ec6  
Software copyright ENERCALC, INC. 1983-2018, Build:10.18.11.30

Lic. # : KW-06007473

Licensee : SHAWN REEDER

Description : 36"x36"x8" Pad Footing

**Footing Flexure**

Flexure Axis & Load Combination	Mu k-ft	Side	Tension Surface	As Req'd in^2	Gvrn. As in^2	Actual As in^2	Phi*Mn k-ft	Status
X-X, +1.40D+1.60H	1.466	+Z	Bottom	0.1728	Min Temp %	0.2667	5.324	OK
X-X, +1.40D+1.60H	1.466	-Z	Bottom	0.1728	Min Temp %	0.2667	5.324	OK
X-X, +1.20D+0.50Lr+1.60L+1.60H	1.256	+Z	Bottom	0.1728	Min Temp %	0.2667	5.324	OK
X-X, +1.20D+0.50Lr+1.60L+1.60H	1.256	-Z	Bottom	0.1728	Min Temp %	0.2667	5.324	OK
X-X, +1.20D+1.60L+0.50S+1.60H	1.256	+Z	Bottom	0.1728	Min Temp %	0.2667	5.324	OK
X-X, +1.20D+1.60L+0.50S+1.60H	1.256	-Z	Bottom	0.1728	Min Temp %	0.2667	5.324	OK
X-X, +1.20D+1.60Lr+0.50L+1.60H	1.256	+Z	Bottom	0.1728	Min Temp %	0.2667	5.324	OK
X-X, +1.20D+1.60Lr+0.50L+1.60H	1.256	-Z	Bottom	0.1728	Min Temp %	0.2667	5.324	OK
X-X, +1.20D+1.60Lr+0.50W+1.60H	1.256	+Z	Bottom	0.1728	Min Temp %	0.2667	5.324	OK
X-X, +1.20D+1.60Lr+0.50W+1.60H	1.256	-Z	Bottom	0.1728	Min Temp %	0.2667	5.324	OK
X-X, +1.20D+0.50L+1.60S+1.60H	1.256	+Z	Bottom	0.1728	Min Temp %	0.2667	5.324	OK
X-X, +1.20D+0.50L+1.60S+1.60H	1.256	-Z	Bottom	0.1728	Min Temp %	0.2667	5.324	OK
X-X, +1.20D+1.60S+0.50W+1.60H	1.256	+Z	Bottom	0.1728	Min Temp %	0.2667	5.324	OK
X-X, +1.20D+1.60S+0.50W+1.60H	1.256	-Z	Bottom	0.1728	Min Temp %	0.2667	5.324	OK
X-X, +1.20D+0.50Lr+0.50L+W+1.60H	1.256	+Z	Bottom	0.1728	Min Temp %	0.2667	5.324	OK
X-X, +1.20D+0.50Lr+0.50L+W+1.60H	1.256	-Z	Bottom	0.1728	Min Temp %	0.2667	5.324	OK
X-X, +1.20D+0.50L+0.50S+W+1.60H	1.256	+Z	Bottom	0.1728	Min Temp %	0.2667	5.324	OK
X-X, +1.20D+0.50L+0.50S+W+1.60H	1.256	-Z	Bottom	0.1728	Min Temp %	0.2667	5.324	OK
X-X, +1.20D+0.50L+0.70S+E+1.60H	1.256	+Z	Bottom	0.1728	Min Temp %	0.2667	5.324	OK
X-X, +1.20D+0.50L+0.70S+E+1.60H	1.256	-Z	Bottom	0.1728	Min Temp %	0.2667	5.324	OK
X-X, +0.90D+W+0.90H	0.9423	+Z	Bottom	0.1728	Min Temp %	0.2667	5.324	OK
X-X, +0.90D+W+0.90H	0.9423	-Z	Bottom	0.1728	Min Temp %	0.2667	5.324	OK
X-X, +0.90D+E+0.90H	0.9423	+Z	Bottom	0.1728	Min Temp %	0.2667	5.324	OK
X-X, +0.90D+E+0.90H	0.9423	-Z	Bottom	0.1728	Min Temp %	0.2667	5.324	OK
Z-Z, +1.40D+1.60H	1.466	-X	Bottom	0.1728	Min Temp %	0.2667	5.324	OK
Z-Z, +1.40D+1.60H	1.466	+X	Bottom	0.1728	Min Temp %	0.2667	5.324	OK
Z-Z, +1.20D+0.50Lr+1.60L+1.60H	1.256	-X	Bottom	0.1728	Min Temp %	0.2667	5.324	OK
Z-Z, +1.20D+0.50Lr+1.60L+1.60H	1.256	+X	Bottom	0.1728	Min Temp %	0.2667	5.324	OK
Z-Z, +1.20D+1.60L+0.50S+1.60H	1.256	-X	Bottom	0.1728	Min Temp %	0.2667	5.324	OK
Z-Z, +1.20D+1.60L+0.50S+1.60H	1.256	+X	Bottom	0.1728	Min Temp %	0.2667	5.324	OK
Z-Z, +1.20D+1.60Lr+0.50L+1.60H	1.256	-X	Bottom	0.1728	Min Temp %	0.2667	5.324	OK
Z-Z, +1.20D+1.60Lr+0.50L+1.60H	1.256	+X	Bottom	0.1728	Min Temp %	0.2667	5.324	OK
Z-Z, +1.20D+1.60Lr+0.50W+1.60H	1.256	-X	Bottom	0.1728	Min Temp %	0.2667	5.324	OK
Z-Z, +1.20D+1.60Lr+0.50W+1.60H	1.256	+X	Bottom	0.1728	Min Temp %	0.2667	5.324	OK
Z-Z, +1.20D+0.50L+1.60S+1.60H	1.256	-X	Bottom	0.1728	Min Temp %	0.2667	5.324	OK
Z-Z, +1.20D+0.50L+1.60S+1.60H	1.256	+X	Bottom	0.1728	Min Temp %	0.2667	5.324	OK
Z-Z, +1.20D+1.60S+0.50W+1.60H	1.256	-X	Bottom	0.1728	Min Temp %	0.2667	5.324	OK
Z-Z, +1.20D+1.60S+0.50W+1.60H	1.256	+X	Bottom	0.1728	Min Temp %	0.2667	5.324	OK
Z-Z, +1.20D+0.50Lr+0.50L+W+1.60H	1.256	-X	Bottom	0.1728	Min Temp %	0.2667	5.324	OK
Z-Z, +1.20D+0.50Lr+0.50L+W+1.60H	1.256	+X	Bottom	0.1728	Min Temp %	0.2667	5.324	OK
Z-Z, +1.20D+0.50L+0.50S+W+1.60H	1.256	-X	Bottom	0.1728	Min Temp %	0.2667	5.324	OK
Z-Z, +1.20D+0.50L+0.50S+W+1.60H	1.256	+X	Bottom	0.1728	Min Temp %	0.2667	5.324	OK
Z-Z, +1.20D+0.50L+0.70S+E+1.60H	1.256	-X	Bottom	0.1728	Min Temp %	0.2667	5.324	OK
Z-Z, +1.20D+0.50L+0.70S+E+1.60H	1.256	+X	Bottom	0.1728	Min Temp %	0.2667	5.324	OK
Z-Z, +0.90D+W+0.90H	0.9423	-X	Bottom	0.1728	Min Temp %	0.2667	5.324	OK
Z-Z, +0.90D+W+0.90H	0.9423	+X	Bottom	0.1728	Min Temp %	0.2667	5.324	OK
Z-Z, +0.90D+E+0.90H	0.9423	-X	Bottom	0.1728	Min Temp %	0.2667	5.324	OK
Z-Z, +0.90D+E+0.90H	0.9423	+X	Bottom	0.1728	Min Temp %	0.2667	5.324	OK

**One Way Shear**

Load Combination...	Vu @ -X	Vu @ +X	Vu @ -Z	Vu @ +Z	Vu:Max	Phi Vn	Vu / Phi*Vn	Status
+1.40D+1.60H	27.65 psi	27.65 psi	27.65 psi	27.65 psi	27.65 psi	75.00 psi	0.37	OK
+1.20D+0.50Lr+1.60L+1.60H	23.70 psi	23.70 psi	23.70 psi	23.70 psi	23.70 psi	75.00 psi	0.32	OK
+1.20D+1.60L+0.50S+1.60H	23.70 psi	23.70 psi	23.70 psi	23.70 psi	23.70 psi	75.00 psi	0.32	OK
+1.20D+1.60Lr+0.50L+1.60H	23.70 psi	23.70 psi	23.70 psi	23.70 psi	23.70 psi	75.00 psi	0.32	OK
+1.20D+1.60Lr+0.50L+1.60H	23.70 psi	23.70 psi	23.70 psi	23.70 psi	23.70 psi	75.00 psi	0.32	OK
+1.20D+0.50L+1.60S+1.60H	23.70 psi	23.70 psi	23.70 psi	23.70 psi	23.70 psi	75.00 psi	0.32	OK
+1.20D+1.60S+0.50W+1.60H	23.70 psi	23.70 psi	23.70 psi	23.70 psi	23.70 psi	75.00 psi	0.32	OK
+1.20D+0.50Lr+0.50L+W+1.60H	23.70 psi	23.70 psi	23.70 psi	23.70 psi	23.70 psi	75.00 psi	0.32	OK
+1.20D+0.50L+0.50S+W+1.60H	23.70 psi	23.70 psi	23.70 psi	23.70 psi	23.70 psi	75.00 psi	0.32	OK
+1.20D+0.50L+0.70S+E+1.60H	23.70 psi	23.70 psi	23.70 psi	23.70 psi	23.70 psi	75.00 psi	0.32	OK
+0.90D+W+0.90H	17.78 psi	17.78 psi	17.78 psi	17.78 psi	17.78 psi	75.00 psi	0.24	OK



Performance Engineers  
 1102 N. Franklin Blvd  
 Nampa, ID 83687

Project Title:  
 Engineer:  
 Project ID:  
 Project Descr:

**General Footing**

File = U:\Desktop\Folders\2018-0\CALCUL-107 Foundation.ec6 .  
 Software copyright ENERCALC, INC. 1983-2018, Build:10.18.11.30 .

Lic. # : KW-06007473

Licensee : SHAWN REEDER

Description : 36"x36"x8" Pad Footing

**One Way Shear**

Load Combination...	Vu @ -X	Vu @ +X	Vu @ -Z	Vu @ +Z	Vu:Max	Phi Vn	Vu / Phi*Vn	Status
+0.90D+E+0.90H	17.78 psi	17.78 psi	17.78 psi	17.78 psi	17.78 psi	75.00 psi	0.24	OK
All units k								

**Two-Way "Punching" Shear**

Load Combination...	Vu	Phi*Vn	Vu / Phi*Vn	Status
+1.40D+1.60H	75.24 psi	150.00psi	0.5016	OK
+1.20D+0.50Lr+1.60L+1.60H	64.49 psi	150.00psi	0.4299	OK
+1.20D+1.60L+0.50S+1.60H	64.49 psi	150.00psi	0.4299	OK
+1.20D+1.60Lr+0.50L+1.60H	64.49 psi	150.00psi	0.4299	OK
+1.20D+1.60Lr+0.50W+1.60H	64.49 psi	150.00psi	0.4299	OK
+1.20D+0.50L+1.60S+1.60H	64.49 psi	150.00psi	0.4299	OK
+1.20D+1.60S+0.50W+1.60H	64.49 psi	150.00psi	0.4299	OK
+1.20D+0.50Lr+0.50L+W+1.60H	64.49 psi	150.00psi	0.4299	OK
+1.20D+0.50L+0.50S+W+1.60H	64.49 psi	150.00psi	0.4299	OK
+1.20D+0.50L+0.70S+E+1.60H	64.49 psi	150.00psi	0.4299	OK
+0.90D+W+0.90H	48.37 psi	150.00psi	0.3225	OK
+0.90D+E+0.90H	48.37 psi	150.00psi	0.3225	OK



**General Footing**

Lic. # : KW-06007473

Licensee : SHAWN REEDER

Description : 48"x48"x8" Pad Footing

**Code References**

Calculations per ACI 318-14, IBC 2015, CBC 2016, ASCE 7-10  
Load Combinations Used : IBC 2015

**General Information**

**Material Properties**

fc : Concrete 28 day strength	=	2.50	ksi
fy : Rebar Yield	=	60.0	ksi
Ec : Concrete Elastic Modulus	=	3,122.0	ksi
Concrete Density	=	145.0	pcf
φ Values Flexure	=	0.90	
Shear	=	0.750	

**Soil Design Values**

Allowable Soil Bearing	=	1.50	ksf
Increase Bearing By Footing Weight	=	No	
Soil Passive Resistance (for Sliding)	=	250.0	pcf
Soil/Concrete Friction Coeff.	=	0.30	

**Analysis Settings**

Min Steel % Bending Reinf.	=		
Min Allow % Temp Reinf.	=	0.00180	
Min. Overturning Safety Factor	=	1.0	: 1
Min. Sliding Safety Factor	=	1.0	: 1
Add Ftg Wt for Soil Pressure	:	Yes	
Use ftg wt for stability, moments & shears	:	Yes	
Add Pedestal Wt for Soil Pressure	:	Yes	
Use Pedestal wt for stability, mom & shear	:	Yes	

**Increases based on footing Depth**

Footing base depth below soil surface	=		ft
Allow press. increase per foot of depth when footing base is below	=		ksf ft

**Increases based on footing plan dimension**

Allowable pressure increase per foot of depth when max. length or width is greater than	=		ksf ft
---	---	--	-----------

**Dimensions**

Width parallel to X-X Axis	=	4.0	ft
Length parallel to Z-Z Axis	=	4.0	ft
Footing Thickness	=	8.0	in
Pedestal dimensions...			
px : parallel to X-X Axis	=	6.0	in
pz : parallel to Z-Z Axis	=	6	in
Height	=	24.0	in
Rebar Centerline to Edge of Concrete... at Bottom of footing	=	3.250	in

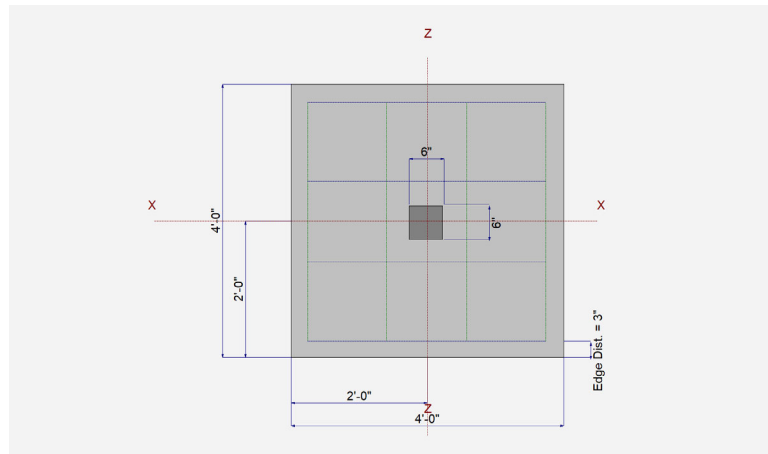

**Reinforcing**

Bars parallel to X-X Axis	=		
Number of Bars	=	4.0	
Reinforcing Bar Size	=	# 4	
Bars parallel to Z-Z Axis	=		
Number of Bars	=	4.0	
Reinforcing Bar Size	=	# 4	
Bandwidth Distribution Check (ACI 15.4.4.2)			
Direction Requiring Closer Separation		n/a	
# Bars required within zone		n/a	
# Bars required on each side of zone		n/a	

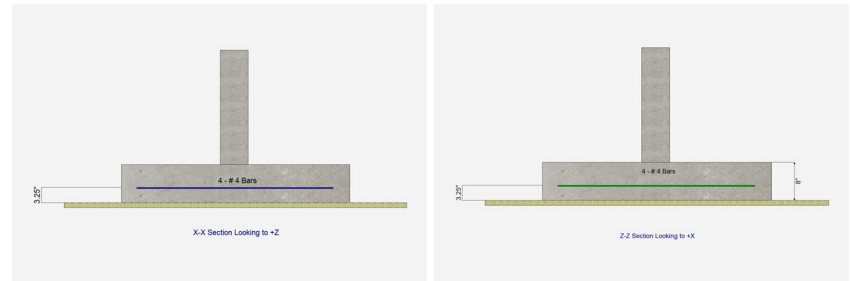

**Applied Loads**

	D	Lr	L	S	W	E	H	
P : Column Load	=	21.50						k
OB : Overburden	=	0.040						ksf
M-xx	=							k-ft
M-zz	=							k-ft
V-x	=							k
V-z	=							k



**General Footing**

Lic. # : KW-06007473

Licensee : SHAWN REEDER

Description : 48"x48"x8" Pad Footing

**DESIGN SUMMARY**

**Design OK**

	Min. Ratio	Item	Applied	Capacity	Governing Load Combination
PASS	0.9893	Soil Bearing	1.484 ksf	1.50 ksf	+D+0.750L+0.750S+0.5250E+H about Z-
PASS	n/a	Overturing - X-X	0.0 k-ft	0.0 k-ft	No Overturing
PASS	n/a	Overturing - Z-Z	0.0 k-ft	0.0 k-ft	No Overturing
PASS	n/a	Sliding - X-X	0.0 k	0.0 k	No Sliding
PASS	n/a	Sliding - Z-Z	0.0 k	0.0 k	No Sliding
PASS	n/a	Uplift	0.0 k	0.0 k	No Uplift
PASS	0.7110	Z Flexure (+X)	2.889 k-ft/ft	4.063 k-ft/ft	+1.40D+1.60H
PASS	0.7110	Z Flexure (-X)	2.889 k-ft/ft	4.063 k-ft/ft	+1.40D+1.60H
PASS	0.7110	X Flexure (+Z)	2.889 k-ft/ft	4.063 k-ft/ft	+1.40D+1.60H
PASS	0.7110	X Flexure (-Z)	2.889 k-ft/ft	4.063 k-ft/ft	+1.40D+1.60H
PASS	0.6002	1-way Shear (+X)	45.016 psi	75.0 psi	+1.40D+1.60H
PASS	0.6002	1-way Shear (-X)	45.016 psi	75.0 psi	+1.40D+1.60H
PASS	0.6002	1-way Shear (+Z)	45.016 psi	75.0 psi	+1.40D+1.60H
PASS	0.6002	1-way Shear (-Z)	45.016 psi	75.0 psi	+1.40D+1.60H
PASS	0.9376	2-way Punching	140.643 psi	150.0 psi	+1.40D+1.60H

**Detailed Results**

**Soil Bearing**

Rotation Axis & Load Combination...	Gross Allowable	Xecc	Zecc (in)	Actual Soil Bearing Stress @ Location				Actual / Allow Ratio
				Bottom, -Z	Top, +Z	Left, -X	Right, +X	
X-X, +D+H	1.50	n/a	0.0	1.484	1.484	n/a	n/a	0.989
X-X, +D+L+H	1.50	n/a	0.0	1.484	1.484	n/a	n/a	0.989
X-X, +D+Lr+H	1.50	n/a	0.0	1.484	1.484	n/a	n/a	0.989
X-X, +D+S+H	1.50	n/a	0.0	1.484	1.484	n/a	n/a	0.989
X-X, +D+0.750Lr+0.750L+H	1.50	n/a	0.0	1.484	1.484	n/a	n/a	0.989
X-X, +D+0.750L+0.750S+H	1.50	n/a	0.0	1.484	1.484	n/a	n/a	0.989
X-X, +D+0.60W+H	1.50	n/a	0.0	1.484	1.484	n/a	n/a	0.989
X-X, +D+0.70E+H	1.50	n/a	0.0	1.484	1.484	n/a	n/a	0.989
X-X, +D+0.750Lr+0.750L+0.450W+H	1.50	n/a	0.0	1.484	1.484	n/a	n/a	0.989
X-X, +D+0.750L+0.750S+0.450W+H	1.50	n/a	0.0	1.484	1.484	n/a	n/a	0.989
X-X, +D+0.750L+0.750S+0.5250E+H	1.50	n/a	0.0	1.484	1.484	n/a	n/a	0.989
X-X, +0.60D+0.60W+0.60H	1.50	n/a	0.0	0.8906	0.8906	n/a	n/a	0.594
X-X, +0.60D+0.70E+0.60H	1.50	n/a	0.0	0.8906	0.8906	n/a	n/a	0.594
Z-Z, +D+H	1.50	0.0	n/a	n/a	n/a	1.484	1.484	0.989
Z-Z, +D+L+H	1.50	0.0	n/a	n/a	n/a	1.484	1.484	0.989
Z-Z, +D+Lr+H	1.50	0.0	n/a	n/a	n/a	1.484	1.484	0.989
Z-Z, +D+S+H	1.50	0.0	n/a	n/a	n/a	1.484	1.484	0.989
Z-Z, +D+0.750Lr+0.750L+H	1.50	0.0	n/a	n/a	n/a	1.484	1.484	0.989
Z-Z, +D+0.750L+0.750S+H	1.50	0.0	n/a	n/a	n/a	1.484	1.484	0.989
Z-Z, +D+0.60W+H	1.50	0.0	n/a	n/a	n/a	1.484	1.484	0.989
Z-Z, +D+0.70E+H	1.50	0.0	n/a	n/a	n/a	1.484	1.484	0.989
Z-Z, +D+0.750Lr+0.750L+0.450W+H	1.50	0.0	n/a	n/a	n/a	1.484	1.484	0.989
Z-Z, +D+0.750L+0.750S+0.450W+H	1.50	0.0	n/a	n/a	n/a	1.484	1.484	0.989
Z-Z, +D+0.750L+0.750S+0.5250E+H	1.50	0.0	n/a	n/a	n/a	1.484	1.484	0.989
Z-Z, +0.60D+0.60W+0.60H	1.50	0.0	n/a	n/a	n/a	0.8906	0.8906	0.594
Z-Z, +0.60D+0.70E+0.60H	1.50	0.0	n/a	n/a	n/a	0.8906	0.8906	0.594

**Overturing Stability**

Rotation Axis & Load Combination...	Overturing Moment	Resisting Moment	Stability Ratio	Status
Footing Has NO Overturing				

**Sliding Stability**

All units k

Force Application Axis Load Combination...	Sliding Force	Resisting Force	Stability Ratio	Status
Footing Has NO Sliding				



Performance Engineers  
1102 N. Franklin Blvd  
Nampa, ID 83687

Project Title:  
Engineer:  
Project ID:  
Project Descr:

**General Footing**

File = U:\Desktop\Folders\2018-0\CALCUL-107 Foundation.ec6  
Software copyright ENERCALC, INC. 1983-2018, Build:10.18.11.30

Lic. # : KW-06007473

Licensee : SHAWN REEDER

Description : 48"x48"x8" Pad Footing

**Footing Flexure**

Flexure Axis & Load Combination	Mu k-ft	Side	Tension Surface	As Req'd in^2	Gvrn. As in^2	Actual As in^2	Phi*Mn k-ft	Status
X-X, +1.40D+1.60H	2.889	+Z	Bottom	0.1728	Min Temp %	0.20	4.063	OK
X-X, +1.40D+1.60H	2.889	-Z	Bottom	0.1728	Min Temp %	0.20	4.063	OK
X-X, +1.20D+0.50Lr+1.60L+1.60H	2.476	+Z	Bottom	0.1728	Min Temp %	0.20	4.063	OK
X-X, +1.20D+0.50Lr+1.60L+1.60H	2.476	-Z	Bottom	0.1728	Min Temp %	0.20	4.063	OK
X-X, +1.20D+1.60L+0.50S+1.60H	2.476	+Z	Bottom	0.1728	Min Temp %	0.20	4.063	OK
X-X, +1.20D+1.60L+0.50S+1.60H	2.476	-Z	Bottom	0.1728	Min Temp %	0.20	4.063	OK
X-X, +1.20D+1.60Lr+0.50L+1.60H	2.476	+Z	Bottom	0.1728	Min Temp %	0.20	4.063	OK
X-X, +1.20D+1.60Lr+0.50L+1.60H	2.476	-Z	Bottom	0.1728	Min Temp %	0.20	4.063	OK
X-X, +1.20D+1.60Lr+0.50W+1.60H	2.476	+Z	Bottom	0.1728	Min Temp %	0.20	4.063	OK
X-X, +1.20D+1.60Lr+0.50W+1.60H	2.476	-Z	Bottom	0.1728	Min Temp %	0.20	4.063	OK
X-X, +1.20D+0.50L+1.60S+1.60H	2.476	+Z	Bottom	0.1728	Min Temp %	0.20	4.063	OK
X-X, +1.20D+0.50L+1.60S+1.60H	2.476	-Z	Bottom	0.1728	Min Temp %	0.20	4.063	OK
X-X, +1.20D+1.60S+0.50W+1.60H	2.476	+Z	Bottom	0.1728	Min Temp %	0.20	4.063	OK
X-X, +1.20D+1.60S+0.50W+1.60H	2.476	-Z	Bottom	0.1728	Min Temp %	0.20	4.063	OK
X-X, +1.20D+0.50Lr+0.50L+W+1.60H	2.476	+Z	Bottom	0.1728	Min Temp %	0.20	4.063	OK
X-X, +1.20D+0.50Lr+0.50L+W+1.60H	2.476	-Z	Bottom	0.1728	Min Temp %	0.20	4.063	OK
X-X, +1.20D+0.50L+0.50S+W+1.60H	2.476	+Z	Bottom	0.1728	Min Temp %	0.20	4.063	OK
X-X, +1.20D+0.50L+0.50S+W+1.60H	2.476	-Z	Bottom	0.1728	Min Temp %	0.20	4.063	OK
X-X, +1.20D+0.50L+0.70S+E+1.60H	2.476	+Z	Bottom	0.1728	Min Temp %	0.20	4.063	OK
X-X, +1.20D+0.50L+0.70S+E+1.60H	2.476	-Z	Bottom	0.1728	Min Temp %	0.20	4.063	OK
X-X, +0.90D+W+0.90H	1.857	+Z	Bottom	0.1728	Min Temp %	0.20	4.063	OK
X-X, +0.90D+W+0.90H	1.857	-Z	Bottom	0.1728	Min Temp %	0.20	4.063	OK
X-X, +0.90D+E+0.90H	1.857	+Z	Bottom	0.1728	Min Temp %	0.20	4.063	OK
X-X, +0.90D+E+0.90H	1.857	-Z	Bottom	0.1728	Min Temp %	0.20	4.063	OK
Z-Z, +1.40D+1.60H	2.889	-X	Bottom	0.1728	Min Temp %	0.20	4.063	OK
Z-Z, +1.40D+1.60H	2.889	+X	Bottom	0.1728	Min Temp %	0.20	4.063	OK
Z-Z, +1.20D+0.50Lr+1.60L+1.60H	2.476	-X	Bottom	0.1728	Min Temp %	0.20	4.063	OK
Z-Z, +1.20D+0.50Lr+1.60L+1.60H	2.476	+X	Bottom	0.1728	Min Temp %	0.20	4.063	OK
Z-Z, +1.20D+1.60L+0.50S+1.60H	2.476	-X	Bottom	0.1728	Min Temp %	0.20	4.063	OK
Z-Z, +1.20D+1.60L+0.50S+1.60H	2.476	+X	Bottom	0.1728	Min Temp %	0.20	4.063	OK
Z-Z, +1.20D+1.60Lr+0.50L+1.60H	2.476	-X	Bottom	0.1728	Min Temp %	0.20	4.063	OK
Z-Z, +1.20D+1.60Lr+0.50L+1.60H	2.476	+X	Bottom	0.1728	Min Temp %	0.20	4.063	OK
Z-Z, +1.20D+1.60Lr+0.50W+1.60H	2.476	-X	Bottom	0.1728	Min Temp %	0.20	4.063	OK
Z-Z, +1.20D+1.60Lr+0.50W+1.60H	2.476	+X	Bottom	0.1728	Min Temp %	0.20	4.063	OK
Z-Z, +1.20D+0.50L+1.60S+1.60H	2.476	-X	Bottom	0.1728	Min Temp %	0.20	4.063	OK
Z-Z, +1.20D+0.50L+1.60S+1.60H	2.476	+X	Bottom	0.1728	Min Temp %	0.20	4.063	OK
Z-Z, +1.20D+1.60S+0.50W+1.60H	2.476	-X	Bottom	0.1728	Min Temp %	0.20	4.063	OK
Z-Z, +1.20D+1.60S+0.50W+1.60H	2.476	+X	Bottom	0.1728	Min Temp %	0.20	4.063	OK
Z-Z, +1.20D+0.50Lr+0.50L+W+1.60H	2.476	-X	Bottom	0.1728	Min Temp %	0.20	4.063	OK
Z-Z, +1.20D+0.50Lr+0.50L+W+1.60H	2.476	+X	Bottom	0.1728	Min Temp %	0.20	4.063	OK
Z-Z, +1.20D+0.50L+0.50S+W+1.60H	2.476	-X	Bottom	0.1728	Min Temp %	0.20	4.063	OK
Z-Z, +1.20D+0.50L+0.50S+W+1.60H	2.476	+X	Bottom	0.1728	Min Temp %	0.20	4.063	OK
Z-Z, +1.20D+0.50L+0.70S+E+1.60H	2.476	-X	Bottom	0.1728	Min Temp %	0.20	4.063	OK
Z-Z, +1.20D+0.50L+0.70S+E+1.60H	2.476	+X	Bottom	0.1728	Min Temp %	0.20	4.063	OK
Z-Z, +0.90D+W+0.90H	1.857	-X	Bottom	0.1728	Min Temp %	0.20	4.063	OK
Z-Z, +0.90D+W+0.90H	1.857	+X	Bottom	0.1728	Min Temp %	0.20	4.063	OK
Z-Z, +0.90D+E+0.90H	1.857	-X	Bottom	0.1728	Min Temp %	0.20	4.063	OK
Z-Z, +0.90D+E+0.90H	1.857	+X	Bottom	0.1728	Min Temp %	0.20	4.063	OK

**One Way Shear**

Load Combination...	Vu @ -X	Vu @ +X	Vu @ -Z	Vu @ +Z	Vu:Max	Phi Vn	Vu / Phi*Vn	Status
+1.40D+1.60H	45.02 psi	45.02 psi	45.02 psi	45.02 psi	45.02 psi	75.00 psi	0.60	OK
+1.20D+0.50Lr+1.60L+1.60H	38.59 psi	38.59 psi	38.59 psi	38.59 psi	38.59 psi	75.00 psi	0.51	OK
+1.20D+1.60L+0.50S+1.60H	38.59 psi	38.59 psi	38.59 psi	38.59 psi	38.59 psi	75.00 psi	0.51	OK
+1.20D+1.60Lr+0.50L+1.60H	38.59 psi	38.59 psi	38.59 psi	38.59 psi	38.59 psi	75.00 psi	0.51	OK
+1.20D+1.60Lr+0.50L+1.60H	38.59 psi	38.59 psi	38.59 psi	38.59 psi	38.59 psi	75.00 psi	0.51	OK
+1.20D+0.50L+1.60S+1.60H	38.59 psi	38.59 psi	38.59 psi	38.59 psi	38.59 psi	75.00 psi	0.51	OK
+1.20D+1.60S+0.50W+1.60H	38.59 psi	38.59 psi	38.59 psi	38.59 psi	38.59 psi	75.00 psi	0.51	OK
+1.20D+0.50Lr+0.50L+W+1.60H	38.59 psi	38.59 psi	38.59 psi	38.59 psi	38.59 psi	75.00 psi	0.51	OK
+1.20D+0.50L+0.50S+W+1.60H	38.59 psi	38.59 psi	38.59 psi	38.59 psi	38.59 psi	75.00 psi	0.51	OK
+1.20D+0.50L+0.70S+E+1.60H	38.59 psi	38.59 psi	38.59 psi	38.59 psi	38.59 psi	75.00 psi	0.51	OK
+0.90D+W+0.90H	28.94 psi	28.94 psi	28.94 psi	28.94 psi	28.94 psi	75.00 psi	0.39	OK



Performance Engineers  
 1102 N. Franklin Blvd  
 Nampa, ID 83687

Project Title:  
 Engineer:  
 Project ID:  
 Project Descr:

## General Footing

File = U:\Desktop\Folders\2018-0\CALCUL-107 Foundation.ec6 .  
 Software copyright ENERCALC, INC. 1983-2018, Build:10.18.11.30 .

Lic. # : KW-06007473

Licensee : SHAWN REEDER

Description : 48"x48"x8" Pad Footing

### One Way Shear

Load Combination...	Vu @ -X	Vu @ +X	Vu @ -Z	Vu @ +Z	Vu:Max	Phi Vn	Vu / Phi*Vn	Status
+0.90D+E+0.90H	28.94 psi	28.94 psi	28.94 psi	28.94 psi	28.94 psi	75.00 psi	0.39	OK
All units k								

### Two-Way "Punching" Shear

Load Combination...	Vu	Phi*Vn	Vu / Phi*Vn	Status
+1.40D+1.60H	140.64 psi	150.00 psi	0.9376	OK
+1.20D+0.50Lr+1.60L+1.60H	120.55 psi	150.00 psi	0.8037	OK
+1.20D+1.60L+0.50S+1.60H	120.55 psi	150.00 psi	0.8037	OK
+1.20D+1.60Lr+0.50L+1.60H	120.55 psi	150.00 psi	0.8037	OK
+1.20D+1.60Lr+0.50W+1.60H	120.55 psi	150.00 psi	0.8037	OK
+1.20D+0.50L+1.60S+1.60H	120.55 psi	150.00 psi	0.8037	OK
+1.20D+1.60S+0.50W+1.60H	120.55 psi	150.00 psi	0.8037	OK
+1.20D+0.50Lr+0.50L+W+1.60H	120.55 psi	150.00 psi	0.8037	OK
+1.20D+0.50L+0.50S+W+1.60H	120.55 psi	150.00 psi	0.8037	OK
+1.20D+0.50L+0.70S+E+1.60H	120.55 psi	150.00 psi	0.8037	OK
+0.90D+W+0.90H	90.41 psi	150.00 psi	0.6028	OK
+0.90D+E+0.90H	90.41 psi	150.00 psi	0.6028	OK



## General Footing

File = U:\Desktop\Folders\2018-0\CALCUL-1107 Foundation.ec6 .  
Software copyright ENERCALC, INC. 1983-2018, Build:10.18.11.30 .

Lic. # : KW-06007473

Licensee : SHAWN REEDER

Description : 54"x54"x10" Pad Footing

### Code References

Calculations per ACI 318-14, IBC 2015, CBC 2016, ASCE 7-10

Load Combinations Used : IBC 2015

### General Information

#### Material Properties

$f_c$ : Concrete 28 day strength	=	2.50	ksi
$f_y$ : Rebar Yield	=	60.0	ksi
$E_c$ : Concrete Elastic Modulus	=	3,122.0	ksi
Concrete Density	=	145.0	pcf
$\phi$ Values Flexure	=	0.90	
Shear	=	0.750	

#### Soil Design Values

Allowable Soil Bearing	=	1.50	ksf
Increase Bearing By Footing Weight	=	No	
Soil Passive Resistance (for Sliding)	=	250.0	pcf
Soil/Concrete Friction Coeff.	=	0.30	

#### Analysis Settings

Min Steel % Bending Reinf.	=	
Min Allow % Temp Reinf.	=	0.00180
Min. Overturning Safety Factor	=	1.0 : 1
Min. Sliding Safety Factor	=	1.0 : 1
Add Ftg Wt for Soil Pressure	:	Yes
Use ftg wt for stability, moments & shears	:	Yes
Add Pedestal Wt for Soil Pressure	:	Yes
Use Pedestal wt for stability, mom & shear	:	Yes

#### Increases based on footing Depth

Footing base depth below soil surface	=	ft
Allow press. increase per foot of depth when footing base is below	=	ksf
	=	ft

#### Increases based on footing plan dimension

Allowable pressure increase per foot of depth when max. length or width is greater than	=	ksf
	=	ft

### Dimensions

Width parallel to X-X Axis	=	4.50	ft
Length parallel to Z-Z Axis	=	4.50	ft
Footing Thickness	=	10.0	in

Pedestal dimensions...	=		
px : parallel to X-X Axis	=	6.0	in
pz : parallel to Z-Z Axis	=	6	in
Height	=	24.0	in
Rebar Centerline to Edge of Concrete... at Bottom of footing	=	3.250	in

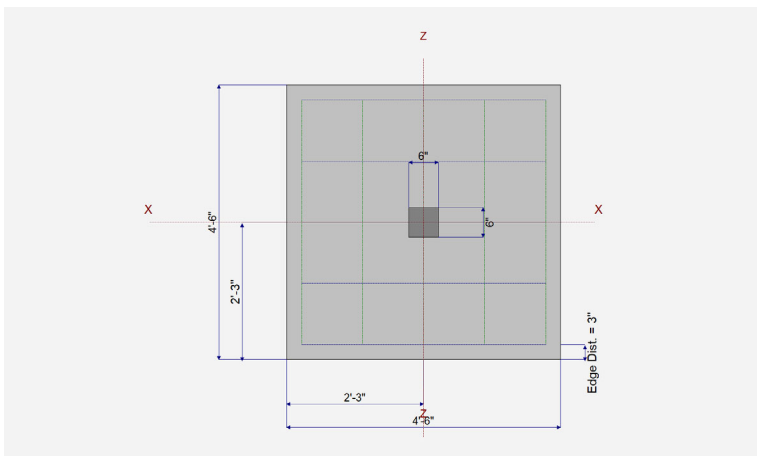

### Reinforcing

Bars parallel to X-X Axis	=	
Number of Bars	=	5.0
Reinforcing Bar Size	=	# 4
Bars parallel to Z-Z Axis	=	
Number of Bars	=	5.0
Reinforcing Bar Size	=	# 4
Bandwidth Distribution Check (ACI 15.4.4.2)		
Direction Requiring Closer Separation		n/a
# Bars required within zone		n/a
# Bars required on each side of zone		n/a

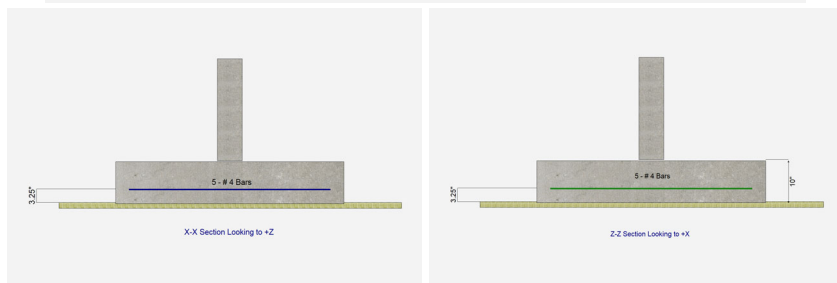

### Applied Loads

	D	Lr	L	S	W	E	H	
P : Column Load	=	27.0						k
OB : Overburden	=	0.040						ksf
M-xx	=							k-ft
M-zz	=							k-ft
V-x	=							k
V-z	=							k



**General Footing**

Lic. # : KW-06007473

Licensee : SHAWN REEDER

Description : 54"x54"x10" Pad Footing

**DESIGN SUMMARY**

**Design OK**

	Min. Ratio	Item	Applied	Capacity	Governing Load Combination
PASS	0.9980	Soil Bearing	1.497 ksf	1.50 ksf	+D+0.750L+0.750S+0.5250E+H about Z-
PASS	n/a	Overturing - X-X	0.0 k-ft	0.0 k-ft	No Overturing
PASS	n/a	Overturing - Z-Z	0.0 k-ft	0.0 k-ft	No Overturing
PASS	n/a	Sliding - X-X	0.0 k	0.0 k	No Sliding
PASS	n/a	Sliding - Z-Z	0.0 k	0.0 k	No Sliding
PASS	n/a	Uplift	0.0 k	0.0 k	No Uplift
PASS	0.5766	Z Flexure (+X)	3.742 k-ft/ft	6.489 k-ft/ft	+1.40D+1.60H
PASS	0.5766	Z Flexure (-X)	3.742 k-ft/ft	6.489 k-ft/ft	+1.40D+1.60H
PASS	0.5766	X Flexure (+Z)	3.742 k-ft/ft	6.489 k-ft/ft	+1.40D+1.60H
PASS	0.5766	X Flexure (-Z)	3.742 k-ft/ft	6.489 k-ft/ft	+1.40D+1.60H
PASS	0.4435	1-way Shear (+X)	33.262 psi	75.0 psi	+1.40D+1.60H
PASS	0.4435	1-way Shear (-X)	33.262 psi	75.0 psi	+1.40D+1.60H
PASS	0.4435	1-way Shear (+Z)	33.262 psi	75.0 psi	+1.40D+1.60H
PASS	0.4435	1-way Shear (-Z)	33.262 psi	75.0 psi	+1.40D+1.60H
PASS	0.6915	2-way Punching	103.719 psi	150.0 psi	+1.40D+1.60H

**Detailed Results**

**Soil Bearing**

Rotation Axis & Load Combination...	Gross Allowable	Xecc	Zecc (in)	Actual Soil Bearing Stress @ Location				Actual / Allow Ratio
				Bottom, -Z	Top, +Z	Left, -X	Right, +X	
X-X, +D+H	1.50	n/a	0.0	1.497	1.497	n/a	n/a	0.998
X-X, +D+L+H	1.50	n/a	0.0	1.497	1.497	n/a	n/a	0.998
X-X, +D+Lr+H	1.50	n/a	0.0	1.497	1.497	n/a	n/a	0.998
X-X, +D+S+H	1.50	n/a	0.0	1.497	1.497	n/a	n/a	0.998
X-X, +D+0.750Lr+0.750L+H	1.50	n/a	0.0	1.497	1.497	n/a	n/a	0.998
X-X, +D+0.750L+0.750S+H	1.50	n/a	0.0	1.497	1.497	n/a	n/a	0.998
X-X, +D+0.60W+H	1.50	n/a	0.0	1.497	1.497	n/a	n/a	0.998
X-X, +D+0.70E+H	1.50	n/a	0.0	1.497	1.497	n/a	n/a	0.998
X-X, +D+0.750Lr+0.750L+0.450W+H	1.50	n/a	0.0	1.497	1.497	n/a	n/a	0.998
X-X, +D+0.750L+0.750S+0.450W+H	1.50	n/a	0.0	1.497	1.497	n/a	n/a	0.998
X-X, +D+0.750L+0.750S+0.5250E+H	1.50	n/a	0.0	1.497	1.497	n/a	n/a	0.998
X-X, +0.60D+0.60W+0.60H	1.50	n/a	0.0	0.8984	0.8984	n/a	n/a	0.599
X-X, +0.60D+0.70E+0.60H	1.50	n/a	0.0	0.8984	0.8984	n/a	n/a	0.599
Z-Z, +D+H	1.50	0.0	n/a	n/a	n/a	1.497	1.497	0.998
Z-Z, +D+L+H	1.50	0.0	n/a	n/a	n/a	1.497	1.497	0.998
Z-Z, +D+Lr+H	1.50	0.0	n/a	n/a	n/a	1.497	1.497	0.998
Z-Z, +D+S+H	1.50	0.0	n/a	n/a	n/a	1.497	1.497	0.998
Z-Z, +D+0.750Lr+0.750L+H	1.50	0.0	n/a	n/a	n/a	1.497	1.497	0.998
Z-Z, +D+0.750L+0.750S+H	1.50	0.0	n/a	n/a	n/a	1.497	1.497	0.998
Z-Z, +D+0.60W+H	1.50	0.0	n/a	n/a	n/a	1.497	1.497	0.998
Z-Z, +D+0.70E+H	1.50	0.0	n/a	n/a	n/a	1.497	1.497	0.998
Z-Z, +D+0.750Lr+0.750L+0.450W+H	1.50	0.0	n/a	n/a	n/a	1.497	1.497	0.998
Z-Z, +D+0.750L+0.750S+0.450W+H	1.50	0.0	n/a	n/a	n/a	1.497	1.497	0.998
Z-Z, +D+0.750L+0.750S+0.5250E+H	1.50	0.0	n/a	n/a	n/a	1.497	1.497	0.998
Z-Z, +0.60D+0.60W+0.60H	1.50	0.0	n/a	n/a	n/a	0.8984	0.8984	0.599
Z-Z, +0.60D+0.70E+0.60H	1.50	0.0	n/a	n/a	n/a	0.8984	0.8984	0.599

**Overturing Stability**

Rotation Axis & Load Combination...	Overturing Moment	Resisting Moment	Stability Ratio	Status
Footing Has NO Overturing				

**Sliding Stability**

All units k

Force Application Axis Load Combination...	Sliding Force	Resisting Force	Stability Ratio	Status
Footing Has NO Sliding				



Performance Engineers  
1102 N. Franklin Blvd  
Nampa, ID 83687

Project Title:  
Engineer:  
Project ID:  
Project Descr:

**General Footing**

File = U:\Desktop\Folders\2018-0\CALCUL-107 Foundation.ec6  
Software copyright ENERCALC, INC. 1983-2018, Build:10.18.11.30

Lic. # : KW-06007473

Licensee : SHAWN REEDER

Description : 54"x54"x10" Pad Footing

**Footing Flexure**

Flexure Axis & Load Combination	Mu k-ft	Side	Tension Surface	As Req'd in^2	Gvrn. As in^2	Actual As in^2	Phi*Mn k-ft	Status
X-X, +1.40D+1.60H	3.742	+Z	Bottom	0.2160	Min Temp %	0.2222	6.489	OK
X-X, +1.40D+1.60H	3.742	-Z	Bottom	0.2160	Min Temp %	0.2222	6.489	OK
X-X, +1.20D+0.50Lr+1.60L+1.60H	3.207	+Z	Bottom	0.2160	Min Temp %	0.2222	6.489	OK
X-X, +1.20D+0.50Lr+1.60L+1.60H	3.207	-Z	Bottom	0.2160	Min Temp %	0.2222	6.489	OK
X-X, +1.20D+1.60L+0.50S+1.60H	3.207	+Z	Bottom	0.2160	Min Temp %	0.2222	6.489	OK
X-X, +1.20D+1.60L+0.50S+1.60H	3.207	-Z	Bottom	0.2160	Min Temp %	0.2222	6.489	OK
X-X, +1.20D+1.60Lr+0.50L+1.60H	3.207	+Z	Bottom	0.2160	Min Temp %	0.2222	6.489	OK
X-X, +1.20D+1.60Lr+0.50L+1.60H	3.207	-Z	Bottom	0.2160	Min Temp %	0.2222	6.489	OK
X-X, +1.20D+1.60Lr+0.50W+1.60H	3.207	+Z	Bottom	0.2160	Min Temp %	0.2222	6.489	OK
X-X, +1.20D+1.60Lr+0.50W+1.60H	3.207	-Z	Bottom	0.2160	Min Temp %	0.2222	6.489	OK
X-X, +1.20D+0.50L+1.60S+1.60H	3.207	+Z	Bottom	0.2160	Min Temp %	0.2222	6.489	OK
X-X, +1.20D+0.50L+1.60S+1.60H	3.207	-Z	Bottom	0.2160	Min Temp %	0.2222	6.489	OK
X-X, +1.20D+1.60S+0.50W+1.60H	3.207	+Z	Bottom	0.2160	Min Temp %	0.2222	6.489	OK
X-X, +1.20D+1.60S+0.50W+1.60H	3.207	-Z	Bottom	0.2160	Min Temp %	0.2222	6.489	OK
X-X, +1.20D+0.50Lr+0.50L+W+1.60H	3.207	+Z	Bottom	0.2160	Min Temp %	0.2222	6.489	OK
X-X, +1.20D+0.50Lr+0.50L+W+1.60H	3.207	-Z	Bottom	0.2160	Min Temp %	0.2222	6.489	OK
X-X, +1.20D+0.50L+0.50S+W+1.60H	3.207	+Z	Bottom	0.2160	Min Temp %	0.2222	6.489	OK
X-X, +1.20D+0.50L+0.50S+W+1.60H	3.207	-Z	Bottom	0.2160	Min Temp %	0.2222	6.489	OK
X-X, +1.20D+0.50L+0.70S+E+1.60H	3.207	+Z	Bottom	0.2160	Min Temp %	0.2222	6.489	OK
X-X, +1.20D+0.50L+0.70S+E+1.60H	3.207	-Z	Bottom	0.2160	Min Temp %	0.2222	6.489	OK
X-X, +0.90D+W+0.90H	2.405	+Z	Bottom	0.2160	Min Temp %	0.2222	6.489	OK
X-X, +0.90D+W+0.90H	2.405	-Z	Bottom	0.2160	Min Temp %	0.2222	6.489	OK
X-X, +0.90D+E+0.90H	2.405	+Z	Bottom	0.2160	Min Temp %	0.2222	6.489	OK
X-X, +0.90D+E+0.90H	2.405	-Z	Bottom	0.2160	Min Temp %	0.2222	6.489	OK
Z-Z, +1.40D+1.60H	3.742	-X	Bottom	0.2160	Min Temp %	0.2222	6.489	OK
Z-Z, +1.40D+1.60H	3.742	+X	Bottom	0.2160	Min Temp %	0.2222	6.489	OK
Z-Z, +1.20D+0.50Lr+1.60L+1.60H	3.207	-X	Bottom	0.2160	Min Temp %	0.2222	6.489	OK
Z-Z, +1.20D+0.50Lr+1.60L+1.60H	3.207	+X	Bottom	0.2160	Min Temp %	0.2222	6.489	OK
Z-Z, +1.20D+1.60L+0.50S+1.60H	3.207	-X	Bottom	0.2160	Min Temp %	0.2222	6.489	OK
Z-Z, +1.20D+1.60L+0.50S+1.60H	3.207	+X	Bottom	0.2160	Min Temp %	0.2222	6.489	OK
Z-Z, +1.20D+1.60Lr+0.50L+1.60H	3.207	-X	Bottom	0.2160	Min Temp %	0.2222	6.489	OK
Z-Z, +1.20D+1.60Lr+0.50L+1.60H	3.207	+X	Bottom	0.2160	Min Temp %	0.2222	6.489	OK
Z-Z, +1.20D+1.60Lr+0.50W+1.60H	3.207	-X	Bottom	0.2160	Min Temp %	0.2222	6.489	OK
Z-Z, +1.20D+1.60Lr+0.50W+1.60H	3.207	+X	Bottom	0.2160	Min Temp %	0.2222	6.489	OK
Z-Z, +1.20D+0.50L+1.60S+1.60H	3.207	-X	Bottom	0.2160	Min Temp %	0.2222	6.489	OK
Z-Z, +1.20D+0.50L+1.60S+1.60H	3.207	+X	Bottom	0.2160	Min Temp %	0.2222	6.489	OK
Z-Z, +1.20D+1.60S+0.50W+1.60H	3.207	-X	Bottom	0.2160	Min Temp %	0.2222	6.489	OK
Z-Z, +1.20D+1.60S+0.50W+1.60H	3.207	+X	Bottom	0.2160	Min Temp %	0.2222	6.489	OK
Z-Z, +1.20D+0.50Lr+0.50L+W+1.60H	3.207	-X	Bottom	0.2160	Min Temp %	0.2222	6.489	OK
Z-Z, +1.20D+0.50Lr+0.50L+W+1.60H	3.207	+X	Bottom	0.2160	Min Temp %	0.2222	6.489	OK
Z-Z, +1.20D+0.50L+0.50S+W+1.60H	3.207	-X	Bottom	0.2160	Min Temp %	0.2222	6.489	OK
Z-Z, +1.20D+0.50L+0.50S+W+1.60H	3.207	+X	Bottom	0.2160	Min Temp %	0.2222	6.489	OK
Z-Z, +1.20D+0.50L+0.70S+E+1.60H	3.207	-X	Bottom	0.2160	Min Temp %	0.2222	6.489	OK
Z-Z, +1.20D+0.50L+0.70S+E+1.60H	3.207	+X	Bottom	0.2160	Min Temp %	0.2222	6.489	OK
Z-Z, +0.90D+W+0.90H	2.405	-X	Bottom	0.2160	Min Temp %	0.2222	6.489	OK
Z-Z, +0.90D+W+0.90H	2.405	+X	Bottom	0.2160	Min Temp %	0.2222	6.489	OK
Z-Z, +0.90D+E+0.90H	2.405	-X	Bottom	0.2160	Min Temp %	0.2222	6.489	OK
Z-Z, +0.90D+E+0.90H	2.405	+X	Bottom	0.2160	Min Temp %	0.2222	6.489	OK

**One Way Shear**

Load Combination...	Vu @ -X	Vu @ +X	Vu @ -Z	Vu @ +Z	Vu:Max	Phi Vn	Vu / Phi*Vn	Status
+1.40D+1.60H	33.26 psi	33.26 psi	33.26 psi	33.26 psi	33.26 psi	75.00 psi	0.44	OK
+1.20D+0.50Lr+1.60L+1.60H	28.51 psi	28.51 psi	28.51 psi	28.51 psi	28.51 psi	75.00 psi	0.38	OK
+1.20D+1.60L+0.50S+1.60H	28.51 psi	28.51 psi	28.51 psi	28.51 psi	28.51 psi	75.00 psi	0.38	OK
+1.20D+1.60Lr+0.50L+1.60H	28.51 psi	28.51 psi	28.51 psi	28.51 psi	28.51 psi	75.00 psi	0.38	OK
+1.20D+1.60Lr+0.50L+1.60H	28.51 psi	28.51 psi	28.51 psi	28.51 psi	28.51 psi	75.00 psi	0.38	OK
+1.20D+0.50L+1.60S+1.60H	28.51 psi	28.51 psi	28.51 psi	28.51 psi	28.51 psi	75.00 psi	0.38	OK
+1.20D+1.60S+0.50W+1.60H	28.51 psi	28.51 psi	28.51 psi	28.51 psi	28.51 psi	75.00 psi	0.38	OK
+1.20D+0.50Lr+0.50L+W+1.60H	28.51 psi	28.51 psi	28.51 psi	28.51 psi	28.51 psi	75.00 psi	0.38	OK
+1.20D+0.50L+0.50S+W+1.60H	28.51 psi	28.51 psi	28.51 psi	28.51 psi	28.51 psi	75.00 psi	0.38	OK
+1.20D+0.50L+0.70S+E+1.60H	28.51 psi	28.51 psi	28.51 psi	28.51 psi	28.51 psi	75.00 psi	0.38	OK
+0.90D+W+0.90H	21.38 psi	21.38 psi	21.38 psi	21.38 psi	21.38 psi	75.00 psi	0.29	OK



Performance Engineers  
 1102 N. Franklin Blvd  
 Nampa, ID 83687

Project Title:  
 Engineer:  
 Project ID:  
 Project Descr:

**General Footing**

File = U:\Desktop\Folders\2018-0\CALCUL-107 Foundation.ec6 .  
 Software copyright ENERCALC, INC. 1983-2018, Build:10.18.11.30 .

Lic. # : KW-06007473

Licensee : SHAWN REEDER

Description : 54"x54"x10" Pad Footing

**One Way Shear**

Load Combination...	Vu @ -X	Vu @ +X	Vu @ -Z	Vu @ +Z	Vu:Max	Phi Vn	Vu / Phi*Vn	Status
+0.90D+E+0.90H	21.38 psi	21.38 psi	21.38 psi	21.38 psi	21.38 psi	75.00 psi	0.29	OK

**Two-Way "Punching" Shear**

All units k

Load Combination...	Vu	Phi*Vn	Vu / Phi*Vn	Status
+1.40D+1.60H	103.72 psi	150.00psi	0.6915	OK
+1.20D+0.50Lr+1.60L+1.60H	88.90 psi	150.00psi	0.5927	OK
+1.20D+1.60L+0.50S+1.60H	88.90 psi	150.00psi	0.5927	OK
+1.20D+1.60Lr+0.50L+1.60H	88.90 psi	150.00psi	0.5927	OK
+1.20D+1.60Lr+0.50W+1.60H	88.90 psi	150.00psi	0.5927	OK
+1.20D+0.50L+1.60S+1.60H	88.90 psi	150.00psi	0.5927	OK
+1.20D+1.60S+0.50W+1.60H	88.90 psi	150.00psi	0.5927	OK
+1.20D+0.50Lr+0.50L+W+1.60H	88.90 psi	150.00psi	0.5927	OK
+1.20D+0.50L+0.50S+W+1.60H	88.90 psi	150.00psi	0.5927	OK
+1.20D+0.50L+0.70S+E+1.60H	88.90 psi	150.00psi	0.5927	OK
+0.90D+W+0.90H	66.68 psi	150.00psi	0.4445	OK
+0.90D+E+0.90H	66.68 psi	150.00psi	0.4445	OK



## Wall Footing

File = C:\Users\SBRADS-1\Desktop\2017-0\CALCUL-1\Enercalc.ec6  
ENERCALC, INC. 1983-2017, Build:10.17.9.13, Ver:10.17.9.13

Lic. # : KW-06007473

Licensee : SHAWN REEDER

Description : 16"x8" Ext Footing

### Code References

Calculations per ACI 318-14, IBC 2015, CBC 2016, ASCE 7-10  
Load Combinations Used : IBC 2015

### General Information

#### Material Properties

$f_c$ : Concrete 28 day strength	=	2.50 ksi
$f_y$ : Rebar Yield	=	60.0 ksi
$E_c$ : Concrete Elastic Modulus	=	3,122.0 ksi
Concrete Density	=	145.0 pcf
$\phi$ Values Flexure	=	0.90
Shear	=	0.750

#### Analysis Settings

Min Steel % Bending Reinf.	=	
Min Allow % Temp Reinf.	=	0.00180
Min. Overturning Safety Factor	=	1.0 : 1
Min. Sliding Safety Factor	=	1.0 : 1
AutoCalc Footing Weight as DL	:	Yes

#### Soil Design Values

Allowable Soil Bearing	=	1.50 ksf
Increase Bearing By Footing Weight	=	No
Soil Passive Resistance (for Sliding)	=	250.0 pcf
Soil/Concrete Friction Coeff.	=	0.30

#### Increases based on footing Depth

Reference Depth below Surface	=	2.0 ft
Allow. Pressure Increase per foot of depth when base footing is below	=	ksf ft

#### Increases based on footing Width

Allow. Pressure Increase per foot of width when footing is wider than	=	ksf ft
---	---	--------

#### Adjusted Allowable Bearing Pressure

= 1.50 ksf

### Dimensions

Footing Width	=	1.330 ft
Wall Thickness	=	6.0 in
Wall center offset from center of footing	=	0 in

### Reinforcing

Footing Thickness	=	8.0 in	Bars along X-X Axis	=	
Rebar Centerline to Edge of Concrete... at Bottom of footing	=	3.0 in	# of Bars in 12" Width	=	2
			Reinforcing Bar Size	=	# 4

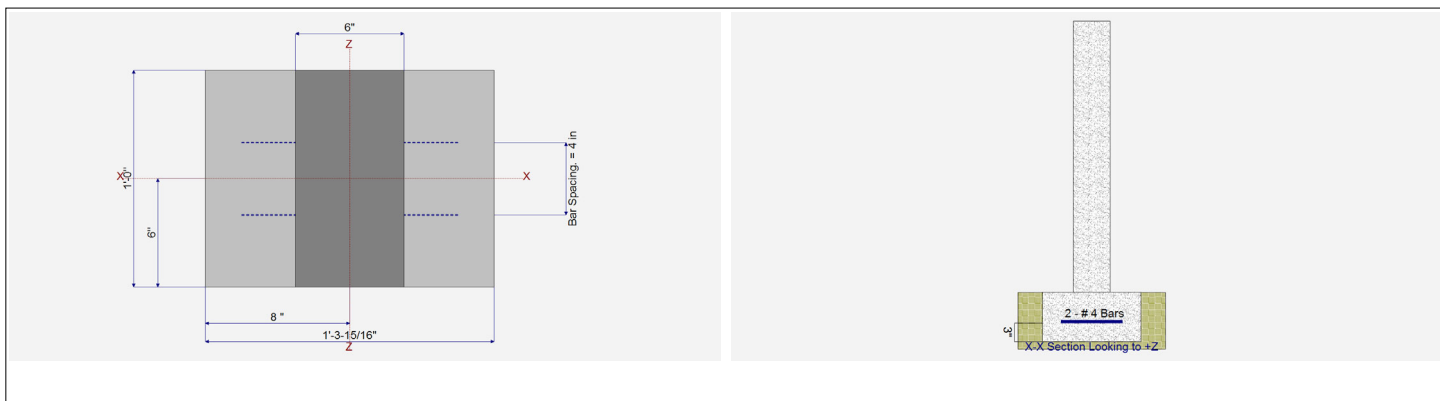

### Applied Loads

	D	Lr	L	S	W	E	H
P : Column Load	=	1.850					k
OB : Overburden	=						ksf
V-x	=						k
M-zz	=						k-ft
Vx applied	=						in above top of footing



## Wall Footing

File = C:\Users\SBRADS-1\Desktop\2017-0\CALCUL-1\Enercalc.ec6  
ENERCALC, INC. 1983-2017, Build:10.17.9.13, Ver:10.17.9.13

Lic. # : KW-06007473

Licensee : SHAWN REEDER

Description : 16"x8" Ext Footing

### DESIGN SUMMARY

**Design OK**

Factor of Safety	Item	Applied	Capacity	Governing Load Combination	
PASS	n/a	Overturning - Z-Z	0.0 k-ft	0.0 k-ft	No Overturning
PASS	n/a	Sliding - X-X	0.0 k	0.0 k	No Sliding
PASS	n/a	Uplift	0.0 k	0.0 k	No Uplift

Utilization Ratio	Item	Applied	Capacity	Governing Load Combination	
PASS	0.9918	Soil Bearing	1.488 ksf	1.50 ksf	+D+0.750L+0.750S+0.5
PASS	0.02199	Z Flexure (+X)	0.1793 k-ft	8.153 k-ft	+1.40D+1.60H
PASS	0.01414	Z Flexure (-X)	0.1153 k-ft	8.153 k-ft	+0.90D+E+0.90H
PASS	n/a	1-way Shear (+X)	0.0 psi	75.0 psi	n/a
PASS	0.0	1-way Shear (-X)	0.0 psi	0.0 psi	n/a

### Detailed Results

#### Soil Bearing

Rotation Axis & Load Combination...	Gross Allowable	Xecc	Actual Soil Bearing Stress		Actual / Allowable Ratio
			-X	+X	
, +D+H	1.50 ksf	0.0 in	1.488 ksf	1.488 ksf	0.992
, +D+L+H	1.50 ksf	0.0 in	1.488 ksf	1.488 ksf	0.992
, +D+Lr+H	1.50 ksf	0.0 in	1.488 ksf	1.488 ksf	0.992
, +D+S+H	1.50 ksf	0.0 in	1.488 ksf	1.488 ksf	0.992
, +D+0.750Lr+0.750L+H	1.50 ksf	0.0 in	1.488 ksf	1.488 ksf	0.992
, +D+0.750L+0.750S+H	1.50 ksf	0.0 in	1.488 ksf	1.488 ksf	0.992
, +D+0.60W+H	1.50 ksf	0.0 in	1.488 ksf	1.488 ksf	0.992
, +D+0.70E+H	1.50 ksf	0.0 in	1.488 ksf	1.488 ksf	0.992
, +D+0.750Lr+0.750L+0.450W+H	1.50 ksf	0.0 in	1.488 ksf	1.488 ksf	0.992
, +D+0.750L+0.750S+0.450W+H	1.50 ksf	0.0 in	1.488 ksf	1.488 ksf	0.992
, +D+0.750L+0.750S+0.5250E+H	1.50 ksf	0.0 in	1.488 ksf	1.488 ksf	0.992
, +0.60D+0.60W+0.60H	1.50 ksf	0.0 in	0.8926 ksf	0.8926 ksf	0.595
, +0.60D+0.70E+0.60H	1.50 ksf	0.0 in	0.8926 ksf	0.8926 ksf	0.595

#### Overturning Stability

Units : k-ft

Rotation Axis & Load Combination...	Overturning Moment	Resisting Moment	Stability Ratio	Status
-------------------------------------	--------------------	------------------	-----------------	--------

Footing Has NO Overturning

#### Sliding Stability

Force Application Axis Load Combination...	Sliding Force	Resisting Force	Sliding SafetyRatio	Status
--	---------------	-----------------	---------------------	--------

Footing Has NO Sliding

#### Footing Flexure

Flexure Axis & Load Combination	Mu k-ft	Which Side ?	Tension @ Bot. or Top ?	As Req'd in^2	Gvrn. As in^2	Actual As in^2	Phi*Mn k-ft	Status
, +1.40D+1.60H	0.1793	-X	Bottom	0.1728	Min Temp %	0.4	8.153	OK
, +1.40D+1.60H	0.1793	+X	Bottom	0.1728	Min Temp %	0.4	8.153	OK
, +1.20D+0.50Lr+1.60L+1.60H	0.1537	-X	Bottom	0.1728	Min Temp %	0.4	8.153	OK
, +1.20D+0.50Lr+1.60L+1.60H	0.1537	+X	Bottom	0.1728	Min Temp %	0.4	8.153	OK
, +1.20D+1.60L+0.50S+1.60H	0.1537	-X	Bottom	0.1728	Min Temp %	0.4	8.153	OK
, +1.20D+1.60L+0.50S+1.60H	0.1537	+X	Bottom	0.1728	Min Temp %	0.4	8.153	OK
, +1.20D+1.60Lr+0.50L+1.60H	0.1537	-X	Bottom	0.1728	Min Temp %	0.4	8.153	OK
, +1.20D+1.60Lr+0.50L+1.60H	0.1537	+X	Bottom	0.1728	Min Temp %	0.4	8.153	OK
, +1.20D+1.60Lr+0.50W+1.60H	0.1537	-X	Bottom	0.1728	Min Temp %	0.4	8.153	OK
, +1.20D+1.60Lr+0.50W+1.60H	0.1537	+X	Bottom	0.1728	Min Temp %	0.4	8.153	OK
, +1.20D+1.60Lr+0.50L+W+1.60H	0.1537	-X	Bottom	0.1728	Min Temp %	0.4	8.153	OK
, +1.20D+1.60Lr+0.50L+W+1.60H	0.1537	+X	Bottom	0.1728	Min Temp %	0.4	8.153	OK
, +1.20D+0.50Lr+0.50L+W+1.60H	0.1537	-X	Bottom	0.1728	Min Temp %	0.4	8.153	OK
, +1.20D+0.50Lr+0.50L+W+1.60H	0.1537	+X	Bottom	0.1728	Min Temp %	0.4	8.153	OK
, +1.20D+0.50L+0.50S+W+1.60H	0.1537	-X	Bottom	0.1728	Min Temp %	0.4	8.153	OK
, +1.20D+0.50L+0.50S+W+1.60H	0.1537	+X	Bottom	0.1728	Min Temp %	0.4	8.153	OK



Performance Engineers  
 1102 N. Franklin Blvd  
 Nampa, ID 83687

Project Title:  
 Engineer:  
 Project Descr:

Project ID:

**Wall Footing**

File = C:\Users\SBRADS~1\Desktop\2017-0\CALCUL~1\Enercalc.ec6  
 ENERCALC, INC. 1983-2017, Build:10.17.9.13, Ver:10.17.9.13

Lic. # : KW-06007473

Licensee : SHAWN REEDER

Description : 16"x8" Ext Footing

, +1.20D+0.50L+0.70S+E+1.60H	0.1537	-X	Bottom	0.1728	Min Temp %	0.4	8.153	OK
, +1.20D+0.50L+0.70S+E+1.60H	0.1537	+X	Bottom	0.1728	Min Temp %	0.4	8.153	OK



Performance Engineers  
1102 N. Franklin Blvd  
Nampa, ID 83687

Project Title:  
Engineer:  
Project Descr:

Project ID:

**Wall Footing**

File = C:\Users\SBRADS-1\Desktop\2017-0\CALCUL-1\Enercalc.ec6  
ENERCALC, INC. 1983-2017, Build:10.17.9.13, Ver:10.17.9.13

Lic. # : KW-06007473

Licensee : SHAWN REEDER

Description : 16"x8" Ext Footing

**Footing Flexure**

Flexure Axis & Load Combination	Mu k-ft	Which Side ?	Tension @ Bot. or Top ?	As Req'd in^2	Gvrn. As in^2	Actual As in^2	Phi*Mn k-ft	Status
, +0.90D+W+0.90H	0.1153	-X	Bottom	0.1728	Min Temp %	0.4	8.153	OK
, +0.90D+W+0.90H	0.1153	+X	Bottom	0.1728	Min Temp %	0.4	8.153	OK
, +0.90D+E+0.90H	0.1153	-X	Bottom	0.1728	Min Temp %	0.4	8.153	OK
, +0.90D+E+0.90H	0.1153	+X	Bottom	0.1728	Min Temp %	0.4	8.153	OK

Units : k

**One Way Shear**

Load Combination...	Vu @ -X	Vu @ +X	Vu:Max	Phi Vn	Vu / Phi*Vn	Status
+1.40D+1.60H	0 psi	0 psi	0 psi	75 psi	0	OK
+1.20D+0.50Lr+1.60L+1.60H	0 psi	0 psi	0 psi	75 psi	0	OK
+1.20D+1.60L+0.50S+1.60H	0 psi	0 psi	0 psi	75 psi	0	OK
+1.20D+1.60Lr+0.50L+1.60H	0 psi	0 psi	0 psi	75 psi	0	OK
+1.20D+1.60Lr+0.50W+1.60H	0 psi	0 psi	0 psi	75 psi	0	OK
+1.20D+0.50L+1.60S+1.60H	0 psi	0 psi	0 psi	75 psi	0	OK
+1.20D+1.60S+0.50W+1.60H	0 psi	0 psi	0 psi	75 psi	0	OK
+1.20D+0.50Lr+0.50L+W+1.60H	0 psi	0 psi	0 psi	75 psi	0	OK
+1.20D+0.50L+0.50S+W+1.60H	0 psi	0 psi	0 psi	75 psi	0	OK
+1.20D+0.50L+0.70S+E+1.60H	0 psi	0 psi	0 psi	75 psi	0	OK
+0.90D+W+0.90H	0 psi	0 psi	0 psi	75 psi	0	OK
+0.90D+E+0.90H	0 psi	0 psi	0 psi	75 psi	0	OK



## Wall Footing

File = C:\Users\SBRADS-1\Desktop\2017-0\CALCUL-1\Enercalc.ec6  
ENERCALC, INC. 1983-2017, Build:10.17.9.13, Ver:10.17.9.13

Lic. # : KW-06007473

Licensee : SHAWN REEDER

Description : 24"x8" Ext Footing

### Code References

Calculations per ACI 318-14, IBC 2015, CBC 2016, ASCE 7-10  
Load Combinations Used : IBC 2015

### General Information

#### Material Properties

$f_c$ : Concrete 28 day strength	=	2.50 ksi
$f_y$ : Rebar Yield	=	60.0 ksi
$E_c$ : Concrete Elastic Modulus	=	3,122.0 ksi
Concrete Density	=	145.0 pcf
$\phi$ Values Flexure	=	0.90
Shear	=	0.750

#### Analysis Settings

Min Steel % Bending Reinf.	=	
Min Allow % Temp Reinf.	=	0.00180
Min. Overturning Safety Factor	=	1.0 : 1
Min. Sliding Safety Factor	=	1.0 : 1
AutoCalc Footing Weight as DL	:	Yes

#### Soil Design Values

Allowable Soil Bearing	=	1.50 ksf
Increase Bearing By Footing Weight	=	No
Soil Passive Resistance (for Sliding)	=	250.0 pcf
Soil/Concrete Friction Coeff.	=	0.30

#### Increases based on footing Depth

Reference Depth below Surface	=	2.0 ft
Allow. Pressure Increase per foot of depth when base footing is below	=	ksf ft

#### Increases based on footing Width

Allow. Pressure Increase per foot of width when footing is wider than	=	ksf ft
---	---	--------

#### Adjusted Allowable Bearing Pressure

= 1.50 ksf

### Dimensions

Footing Width	=	2.0 ft
Wall Thickness	=	6.0 in
Wall center offset from center of footing	=	0 in

### Reinforcing

Footing Thickness	=	8.0 in	Bars along X-X Axis	=	
Rebar Centerline to Edge of Concrete... at Bottom of footing	=	3.0 in	# of Bars in 12" Width	=	2
			Reinforcing Bar Size	=	# 4

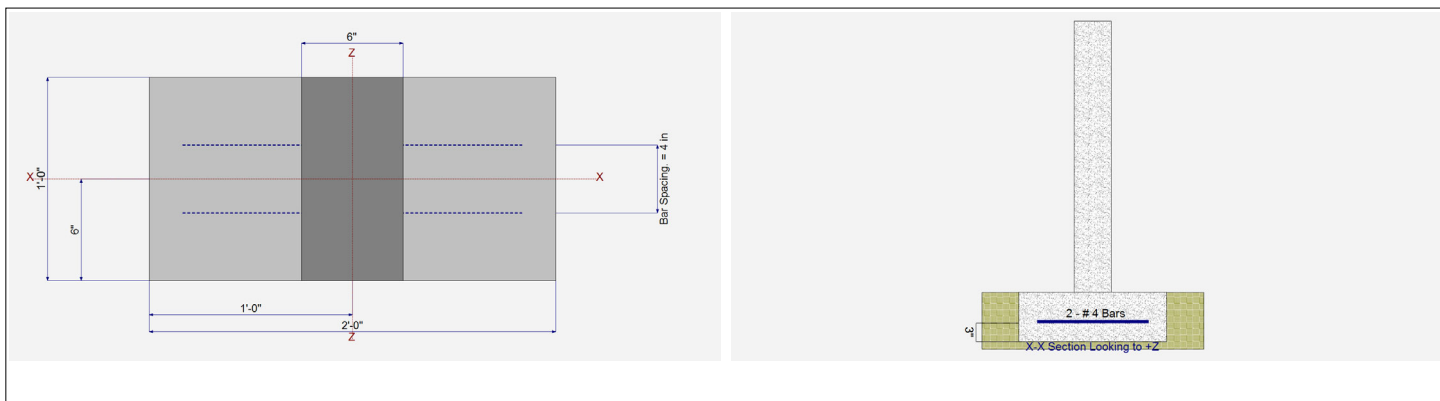

### Applied Loads

	D	Lr	L	S	W	E	H
P : Column Load	=	2.80					k
OB : Overburden	=						ksf
V-x	=						k
M-zz	=						k-ft
Vx applied	=		in	above top of footing			



## Wall Footing

File = C:\Users\SBRADS-1\Desktop\2017-0\CALCUL-1\Enercalc.ec6  
ENERCALC, INC. 1983-2017, Build:10.17.9.13, Ver:10.17.9.13

Lic. # : KW-06007473

Licensee : SHAWN REEDER

Description : 24"x8" Ext Footing

### DESIGN SUMMARY

**Design OK**

Factor of Safety	Item	Applied	Capacity	Governing Load Combination	
PASS	n/a	Overturning - Z-Z	0.0 k-ft	0.0 k-ft	No Overturning
PASS	n/a	Sliding - X-X	0.0 k	0.0 k	No Sliding
PASS	n/a	Uplift	0.0 k	0.0 k	No Uplift

Utilization Ratio	Item	Applied	Capacity	Governing Load Combination	
PASS	0.9978	Soil Bearing	1.497 ksf	1.50 ksf	+D+0.750L+0.750S+0.5
PASS	0.07228	Z Flexure (+X)	0.5893 k-ft	8.153 k-ft	+1.40D+1.60H
PASS	0.04647	Z Flexure (-X)	0.3788 k-ft	8.153 k-ft	+0.90D+E+0.90H
PASS	0.1614	1-way Shear (+X)	12.106 psi	75.0 psi	+1.40D+1.60H
PASS	0.1614	1-way Shear (-X)	12.106 psi	75.0 psi	+1.40D+1.60H

### Detailed Results

#### Soil Bearing

Rotation Axis & Load Combination...	Gross Allowable	Xecc	Actual Soil Bearing Stress		Actual / Allowable Ratio
			-X	+X	
, +D+H	1.50 ksf	0.0 in	1.497 ksf	1.497 ksf	0.998
, +D+L+H	1.50 ksf	0.0 in	1.497 ksf	1.497 ksf	0.998
, +D+Lr+H	1.50 ksf	0.0 in	1.497 ksf	1.497 ksf	0.998
, +D+S+H	1.50 ksf	0.0 in	1.497 ksf	1.497 ksf	0.998
, +D+0.750Lr+0.750L+H	1.50 ksf	0.0 in	1.497 ksf	1.497 ksf	0.998
, +D+0.750L+0.750S+H	1.50 ksf	0.0 in	1.497 ksf	1.497 ksf	0.998
, +D+0.60W+H	1.50 ksf	0.0 in	1.497 ksf	1.497 ksf	0.998
, +D+0.70E+H	1.50 ksf	0.0 in	1.497 ksf	1.497 ksf	0.998
, +D+0.750Lr+0.750L+0.450W+H	1.50 ksf	0.0 in	1.497 ksf	1.497 ksf	0.998
, +D+0.750L+0.750S+0.450W+H	1.50 ksf	0.0 in	1.497 ksf	1.497 ksf	0.998
, +D+0.750L+0.750S+0.5250E+H	1.50 ksf	0.0 in	1.497 ksf	1.497 ksf	0.998
, +0.60D+0.60W+0.60H	1.50 ksf	0.0 in	0.8980 ksf	0.8980 ksf	0.599
, +0.60D+0.70E+0.60H	1.50 ksf	0.0 in	0.8980 ksf	0.8980 ksf	0.599

Units : k-ft

#### Overturning Stability

Rotation Axis & Load Combination...	Overturning Moment	Resisting Moment	Stability Ratio	Status
Footing Has NO Overturning				

#### Sliding Stability

Force Application Axis Load Combination...	Sliding Force	Resisting Force	Sliding SafetyRatio	Status
Footing Has NO Sliding				

#### Footing Flexure

Flexure Axis & Load Combination	Mu k-ft	Which Side ?	Tension @ Bot. or Top ?	As Req'd in^2	Gvrn. As in^2	Actual As in^2	Phi*Mn k-ft	Status
, +1.40D+1.60H	0.5893	-X	Bottom	0.1728	Min Temp %	0.4	8.153	OK
, +1.40D+1.60H	0.5893	+X	Bottom	0.1728	Min Temp %	0.4	8.153	OK
, +1.20D+0.50Lr+1.60L+1.60H	0.5051	-X	Bottom	0.1728	Min Temp %	0.4	8.153	OK
, +1.20D+0.50Lr+1.60L+1.60H	0.5051	+X	Bottom	0.1728	Min Temp %	0.4	8.153	OK
, +1.20D+1.60L+0.50S+1.60H	0.5051	-X	Bottom	0.1728	Min Temp %	0.4	8.153	OK
, +1.20D+1.60L+0.50S+1.60H	0.5051	+X	Bottom	0.1728	Min Temp %	0.4	8.153	OK
, +1.20D+1.60Lr+0.50L+1.60H	0.5051	-X	Bottom	0.1728	Min Temp %	0.4	8.153	OK
, +1.20D+1.60Lr+0.50L+1.60H	0.5051	+X	Bottom	0.1728	Min Temp %	0.4	8.153	OK
, +1.20D+1.60Lr+0.50W+1.60H	0.5051	-X	Bottom	0.1728	Min Temp %	0.4	8.153	OK
, +1.20D+1.60Lr+0.50W+1.60H	0.5051	+X	Bottom	0.1728	Min Temp %	0.4	8.153	OK
, +1.20D+1.60Lr+0.50L+W+1.60H	0.5051	-X	Bottom	0.1728	Min Temp %	0.4	8.153	OK
, +1.20D+1.60Lr+0.50L+W+1.60H	0.5051	+X	Bottom	0.1728	Min Temp %	0.4	8.153	OK
, +1.20D+0.50Lr+0.50L+W+1.60H	0.5051	-X	Bottom	0.1728	Min Temp %	0.4	8.153	OK
, +1.20D+0.50Lr+0.50L+W+1.60H	0.5051	+X	Bottom	0.1728	Min Temp %	0.4	8.153	OK



Performance Engineers  
 1102 N. Franklin Blvd  
 Nampa, ID 83687

Project Title:  
 Engineer:  
 Project Descr:

Project ID:

**Wall Footing**

File = C:\Users\SBRADS-1\Desktop\2017-0\CALCUL-1\Enercalc.ec6  
 ENERCALC, INC. 1983-2017, Build:10.17.9.13, Ver:10.17.9.13

Lic. # : KW-06007473

Licensee : SHAWN REEDER

Description : 24"x8" Ext Footing

, +1.20D+0.50L+0.70S+E+1.60H	0.5051	-X	Bottom	0.1728	Min Temp %	0.4	8.153	OK
, +1.20D+0.50L+0.70S+E+1.60H	0.5051	+X	Bottom	0.1728	Min Temp %	0.4	8.153	OK



Performance Engineers  
1102 N. Franklin Blvd  
Nampa, ID 83687

Project Title:  
Engineer:  
Project Descr:

Project ID:

## Wall Footing

File = C:\Users\SBRADs-1\Desktop\2017-0\CALCUL-1\Enercalc.ec6  
ENERCALC, INC. 1983-2017, Build:10.17.9.13, Ver:10.17.9.13

Lic. # : KW-06007473

Licensee : SHAWN REEDER

Description : 24"x8" Ext Footing

### Footing Flexure

Flexure Axis & Load Combination	Mu k-ft	Which Side ?	Tension @ Bot. or Top ?	As Req'd in <sup>2</sup>	Gvrn. As in <sup>2</sup>	Actual As in <sup>2</sup>	Phi*Mn k-ft	Status
, +0.90D+W+0.90H	0.3788	-X	Bottom	0.1728	Min Temp %	0.4	8.153	OK
, +0.90D+W+0.90H	0.3788	+X	Bottom	0.1728	Min Temp %	0.4	8.153	OK
, +0.90D+E+0.90H	0.3788	-X	Bottom	0.1728	Min Temp %	0.4	8.153	OK
, +0.90D+E+0.90H	0.3788	+X	Bottom	0.1728	Min Temp %	0.4	8.153	OK

### One Way Shear

Units : k

Load Combination...	Vu @ -X	Vu @ +X	Vu:Max	Phi Vn	Vu / Phi*Vn	Status
+1.40D+1.60H	12.106 psi	12.106 psi	12.106 psi	75 psi	0.1614	OK
+1.20D+0.50Lr+1.60L+1.60H	10.377 psi	10.377 psi	10.377 psi	75 psi	0.1384	OK
+1.20D+1.60L+0.50S+1.60H	10.377 psi	10.377 psi	10.377 psi	75 psi	0.1384	OK
+1.20D+1.60Lr+0.50L+1.60H	10.377 psi	10.377 psi	10.377 psi	75 psi	0.1384	OK
+1.20D+1.60Lr+0.50W+1.60H	10.377 psi	10.377 psi	10.377 psi	75 psi	0.1384	OK
+1.20D+0.50L+1.60S+1.60H	10.377 psi	10.377 psi	10.377 psi	75 psi	0.1384	OK
+1.20D+1.60S+0.50W+1.60H	10.377 psi	10.377 psi	10.377 psi	75 psi	0.1384	OK
+1.20D+0.50Lr+0.50L+W+1.60H	10.377 psi	10.377 psi	10.377 psi	75 psi	0.1384	OK
+1.20D+0.50L+0.50S+W+1.60H	10.377 psi	10.377 psi	10.377 psi	75 psi	0.1384	OK
+1.20D+0.50L+0.70S+E+1.60H	10.377 psi	10.377 psi	10.377 psi	75 psi	0.1384	OK
+0.90D+W+0.90H	7.783 psi	7.783 psi	7.783 psi	75 psi	0.1038	OK
+0.90D+E+0.90H	7.783 psi	7.783 psi	7.783 psi	75 psi	0.1038	OK



## Wall Footing

File = C:\Users\SBRADS~1\Desktop\2017-0\CALCUL~1\Enercalc.ec6  
ENERCALC, INC. 1983-2017, Build:10.17.9.13, Ver:10.17.9.13

Lic. # : KW-06007473

Licensee : SHAWN REEDER

Description : 30"x10" Ext Footing

### Code References

Calculations per ACI 318-14, IBC 2015, CBC 2016, ASCE 7-10  
Load Combinations Used : IBC 2015

### General Information

#### Material Properties

$f_c$ : Concrete 28 day strength	=	2.50 ksi
$f_y$ : Rebar Yield	=	60.0 ksi
$E_c$ : Concrete Elastic Modulus	=	3,122.0 ksi
Concrete Density	=	145.0 pcf
$\phi$ Values Flexure	=	0.90
Shear	=	0.750

#### Analysis Settings

Min Steel % Bending Reinf.	=	
Min Allow % Temp Reinf.	=	0.00180
Min. Overturning Safety Factor	=	1.0 : 1
Min. Sliding Safety Factor	=	1.0 : 1
AutoCalc Footing Weight as DL	:	Yes

#### Soil Design Values

Allowable Soil Bearing	=	1.50 ksf
Increase Bearing By Footing Weight	=	No
Soil Passive Resistance (for Sliding)	=	250.0 pcf
Soil/Concrete Friction Coeff.	=	0.30

#### Increases based on footing Depth

Reference Depth below Surface	=	2.0 ft
Allow. Pressure Increase per foot of depth when base footing is below	=	ksf ft

#### Increases based on footing Width

Allow. Pressure Increase per foot of width when footing is wider than	=	ksf ft
---	---	--------

Adjusted Allowable Bearing Pressure = 1.50 ksf

### Dimensions

Footing Width	=	2.50 ft
Wall Thickness	=	6.0 in
Wall center offset from center of footing	=	0 in

### Reinforcing

Footing Thickness	=	10.0 in	Bars along X-X Axis	=	
Rebar Centerline to Edge of Concrete... at Bottom of footing	=	3.0 in	Bar spacing	=	11.00
			Reinforcing Bar Size	=	# 4

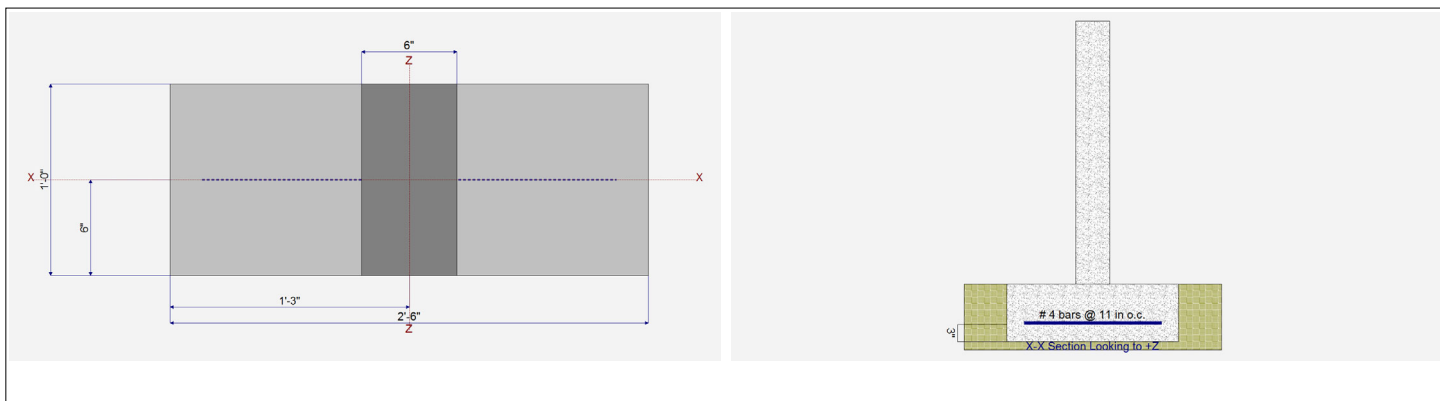

### Applied Loads

	D	Lr	L	S	W	E	H	
P : Column Load	=	3.40						k
OB : Overburden	=							ksf
V-x	=							k
M-zz	=							k-ft
Vx applied	=							in above top of footing



**Wall Footing**

File = C:\Users\SBRADS-1\Desktop\2017-0\CALCUL-1\Enercalc.ec6  
ENERCALC, INC. 1983-2017, Build:10.17.9.13, Ver:10.17.9.13

Lic. # : KW-06007473

Licensee : SHAWN REEDER

Description : 30"x10" Ext Footing

**DESIGN SUMMARY**

**Design OK**

Factor of Safety	Item	Applied	Capacity	Governing Load Combination	
PASS	n/a	Overturning - Z-Z	0.0 k-ft	0.0 k-ft	No Overturning
PASS	n/a	Sliding - X-X	0.0 k	0.0 k	No Sliding
PASS	n/a	Uplift	0.0 k	0.0 k	No Uplift

Utilization Ratio	Item	Applied	Capacity	Governing Load Combination	
PASS	0.9872	Soil Bearing	1.481 ksf	1.50 ksf	+D+0.750L+0.750S+0.5
PASS	0.1566	Z Flexure (+X)	1.037 k-ft	6.621 k-ft	+1.40D+1.60H
PASS	0.1007	Z Flexure (-X)	0.6664 k-ft	6.621 k-ft	+0.90D+E+0.90H
PASS	0.1316	1-way Shear (+X)	9.872 psi	75.0 psi	+1.40D+1.60H
PASS	0.1426	1-way Shear (-X)	10.695 psi	75.0 psi	+1.40D+1.60H

**Detailed Results**

**Soil Bearing**

Rotation Axis & Load Combination...	Gross Allowable	Xecc	Actual Soil Bearing Stress		Actual / Allowable Ratio
			-X	+X	
, +D+H	1.50 ksf	0.0 in	1.481 ksf	1.481 ksf	0.987
, +D+L+H	1.50 ksf	0.0 in	1.481 ksf	1.481 ksf	0.987
, +D+Lr+H	1.50 ksf	0.0 in	1.481 ksf	1.481 ksf	0.987
, +D+S+H	1.50 ksf	0.0 in	1.481 ksf	1.481 ksf	0.987
, +D+0.750Lr+0.750L+H	1.50 ksf	0.0 in	1.481 ksf	1.481 ksf	0.987
, +D+0.750L+0.750S+H	1.50 ksf	0.0 in	1.481 ksf	1.481 ksf	0.987
, +D+0.60W+H	1.50 ksf	0.0 in	1.481 ksf	1.481 ksf	0.987
, +D+0.70E+H	1.50 ksf	0.0 in	1.481 ksf	1.481 ksf	0.987
, +D+0.750Lr+0.750L+0.450W+H	1.50 ksf	0.0 in	1.481 ksf	1.481 ksf	0.987
, +D+0.750L+0.750S+0.450W+H	1.50 ksf	0.0 in	1.481 ksf	1.481 ksf	0.987
, +D+0.750L+0.750S+0.5250E+H	1.50 ksf	0.0 in	1.481 ksf	1.481 ksf	0.987
, +0.60D+0.60W+0.60H	1.50 ksf	0.0 in	0.8885 ksf	0.8885 ksf	0.592
, +0.60D+0.70E+0.60H	1.50 ksf	0.0 in	0.8885 ksf	0.8885 ksf	0.592

**Overturning Stability**

Units : k-ft

Rotation Axis & Load Combination...	Overturning Moment	Resisting Moment	Stability Ratio	Status
-------------------------------------	--------------------	------------------	-----------------	--------

Footing Has NO Overturning

**Sliding Stability**

Force Application Axis Load Combination...	Sliding Force	Resisting Force	Sliding SafetyRatio	Status
--	---------------	-----------------	---------------------	--------

Footing Has NO Sliding

**Footing Flexure**

Flexure Axis & Load Combination	Mu k-ft	Which Side ?	Tension @ Bot. or Top ?	As Req'd in^2	Gvrn. As in^2	Actual As in^2	Phi*Mn k-ft	Status
, +1.40D+1.60H	1.037	-X	Bottom	0.216	Min Temp %	0.2182	6.621	OK
, +1.40D+1.60H	1.037	+X	Bottom	0.216	Min Temp %	0.2182	6.621	OK
, +1.20D+0.50Lr+1.60L+1.60H	0.8885	-X	Bottom	0.216	Min Temp %	0.2182	6.621	OK
, +1.20D+0.50Lr+1.60L+1.60H	0.8885	+X	Bottom	0.216	Min Temp %	0.2182	6.621	OK
, +1.20D+1.60L+0.50S+1.60H	0.8885	-X	Bottom	0.216	Min Temp %	0.2182	6.621	OK
, +1.20D+1.60L+0.50S+1.60H	0.8885	+X	Bottom	0.216	Min Temp %	0.2182	6.621	OK
, +1.20D+1.60Lr+0.50L+1.60H	0.8885	-X	Bottom	0.216	Min Temp %	0.2182	6.621	OK
, +1.20D+1.60Lr+0.50L+1.60H	0.8885	+X	Bottom	0.216	Min Temp %	0.2182	6.621	OK
, +1.20D+1.60Lr+0.50W+1.60H	0.8885	-X	Bottom	0.216	Min Temp %	0.2182	6.621	OK
, +1.20D+1.60Lr+0.50W+1.60H	0.8885	+X	Bottom	0.216	Min Temp %	0.2182	6.621	OK
, +1.20D+0.50Lr+1.60S+1.60H	0.8885	-X	Bottom	0.216	Min Temp %	0.2182	6.621	OK
, +1.20D+0.50Lr+1.60S+1.60H	0.8885	+X	Bottom	0.216	Min Temp %	0.2182	6.621	OK
, +1.20D+1.60S+0.50W+1.60H	0.8885	-X	Bottom	0.216	Min Temp %	0.2182	6.621	OK
, +1.20D+1.60S+0.50W+1.60H	0.8885	+X	Bottom	0.216	Min Temp %	0.2182	6.621	OK
, +1.20D+0.50Lr+0.50L+W+1.60H	0.8885	-X	Bottom	0.216	Min Temp %	0.2182	6.621	OK
, +1.20D+0.50Lr+0.50L+W+1.60H	0.8885	+X	Bottom	0.216	Min Temp %	0.2182	6.621	OK
, +1.20D+0.50L+0.50S+W+1.60H	0.8885	-X	Bottom	0.216	Min Temp %	0.2182	6.621	OK
, +1.20D+0.50L+0.50S+W+1.60H	0.8885	+X	Bottom	0.216	Min Temp %	0.2182	6.621	OK



Performance Engineers  
 1102 N. Franklin Blvd  
 Nampa, ID 83687

Project Title:  
 Engineer:  
 Project Descr:

Project ID:

**Wall Footing**

File = C:\Users\SBRADS-1\Desktop\2017-0\CALCUL-1\Enercalc.ec6  
 ENERCALC, INC. 1983-2017, Build:10.17.9.13, Ver:10.17.9.13

Lic. # : KW-06007473

Licensee : SHAWN REEDER

Description : 30"x10" Ext Footing

, +1.20D+0.50L+0.70S+E+1.60H	0.8885	-X	Bottom	0.216	Min Temp %	0.2182	6.621	OK
, +1.20D+0.50L+0.70S+E+1.60H	0.8885	+X	Bottom	0.216	Min Temp %	0.2182	6.621	OK



Performance Engineers  
1102 N. Franklin Blvd  
Nampa, ID 83687

Project Title:  
Engineer:  
Project Descr:

Project ID:

## Wall Footing

File = C:\Users\SBRADS-1\Desktop\2017-0\CALCUL-1\Enercalc.ec6  
ENERCALC, INC. 1983-2017, Build:10.17.9.13, Ver:10.17.9.13

Lic. # : KW-06007473

Licensee : SHAWN REEDER

Description : 30"x10" Ext Footing

### Footing Flexure

Flexure Axis & Load Combination	Mu k-ft	Which Side ?	Tension @ Bot. or Top ?	As Req'd in <sup>2</sup>	Gvrn. As in <sup>2</sup>	Actual As in <sup>2</sup>	Phi*Mn k-ft	Status
, +0.90D+W+0.90H	0.6664	-X	Bottom	0.216	Min Temp %	0.2182	6.621	OK
, +0.90D+W+0.90H	0.6664	+X	Bottom	0.216	Min Temp %	0.2182	6.621	OK
, +0.90D+E+0.90H	0.6664	-X	Bottom	0.216	Min Temp %	0.2182	6.621	OK
, +0.90D+E+0.90H	0.6664	+X	Bottom	0.216	Min Temp %	0.2182	6.621	OK

### One Way Shear

Units : k

Load Combination...	Vu @ -X	Vu @ +X	Vu:Max	Phi Vn	Vu / Phi*Vn	Status
+1.40D+1.60H	10.695 psi	9.872 psi	10.695 psi	75 psi	0.1426	OK
+1.20D+0.50Lr+1.60L+1.60H	9.167 psi	8.462 psi	9.167 psi	75 psi	0.1222	OK
+1.20D+1.60L+0.50S+1.60H	9.167 psi	8.462 psi	9.167 psi	75 psi	0.1222	OK
+1.20D+1.60Lr+0.50L+1.60H	9.167 psi	8.462 psi	9.167 psi	75 psi	0.1222	OK
+1.20D+1.60Lr+0.50W+1.60H	9.167 psi	8.462 psi	9.167 psi	75 psi	0.1222	OK
+1.20D+0.50L+1.60S+1.60H	9.167 psi	8.462 psi	9.167 psi	75 psi	0.1222	OK
+1.20D+1.60S+0.50W+1.60H	9.167 psi	8.462 psi	9.167 psi	75 psi	0.1222	OK
+1.20D+0.50Lr+0.50L+W+1.60H	9.167 psi	8.462 psi	9.167 psi	75 psi	0.1222	OK
+1.20D+0.50L+0.50S+W+1.60H	9.167 psi	8.462 psi	9.167 psi	75 psi	0.1222	OK
+1.20D+0.50L+0.70S+E+1.60H	9.167 psi	8.462 psi	9.167 psi	75 psi	0.1222	OK
+0.90D+W+0.90H	6.875 psi	6.346 psi	6.875 psi	75 psi	0.09167	OK
+0.90D+E+0.90H	6.875 psi	6.346 psi	6.875 psi	75 psi	0.09167	OK



## Wall Footing

File = C:\Users\SBRADs-1\Desktop\2017-0\CALCUL-1\Enercalc.ec6  
ENERCALC, INC. 1983-2017, Build:10.17.9.13, Ver:10.17.9.13

Lic. # : KW-06007473

Licensee : SHAWN REEDER

Description : 42"x10" Ext Footing

### Code References

Calculations per ACI 318-14, IBC 2015, CBC 2016, ASCE 7-10  
Load Combinations Used : IBC 2015

### General Information

#### Material Properties

$f_c$ : Concrete 28 day strength	=	2.50 ksi
$f_y$ : Rebar Yield	=	60.0 ksi
$E_c$ : Concrete Elastic Modulus	=	3,122.0 ksi
Concrete Density	=	145.0 pcf
$\phi$ Values Flexure	=	0.90
Shear	=	0.750

#### Analysis Settings

Min Steel % Bending Reinf.	=	
Min Allow % Temp Reinf.	=	0.00180
Min. Overturning Safety Factor	=	1.0 : 1
Min. Sliding Safety Factor	=	1.0 : 1
AutoCalc Footing Weight as DL	:	Yes

#### Soil Design Values

Allowable Soil Bearing	=	1.50 ksf
Increase Bearing By Footing Weight	=	No
Soil Passive Resistance (for Sliding)	=	250.0 pcf
Soil/Concrete Friction Coeff.	=	0.30

#### Increases based on footing Depth

Reference Depth below Surface	=	2.0 ft
Allow. Pressure Increase per foot of depth when base footing is below	=	ksf ft

#### Increases based on footing Width

Allow. Pressure Increase per foot of width when footing is wider than	=	ksf ft
---	---	--------

#### Adjusted Allowable Bearing Pressure

= 1.50 ksf

### Dimensions

Footing Width	=	3.50 ft
Wall Thickness	=	6.0 in
Wall center offset from center of footing	=	0 in

### Reinforcing

Footing Thickness	=	10.0 in	Bars along X-X Axis	=	
Rebar Centerline to Edge of Concrete... at Bottom of footing	=	3.0 in	# of Bars in 12" Width	=	4
			Reinforcing Bar Size	=	# 4

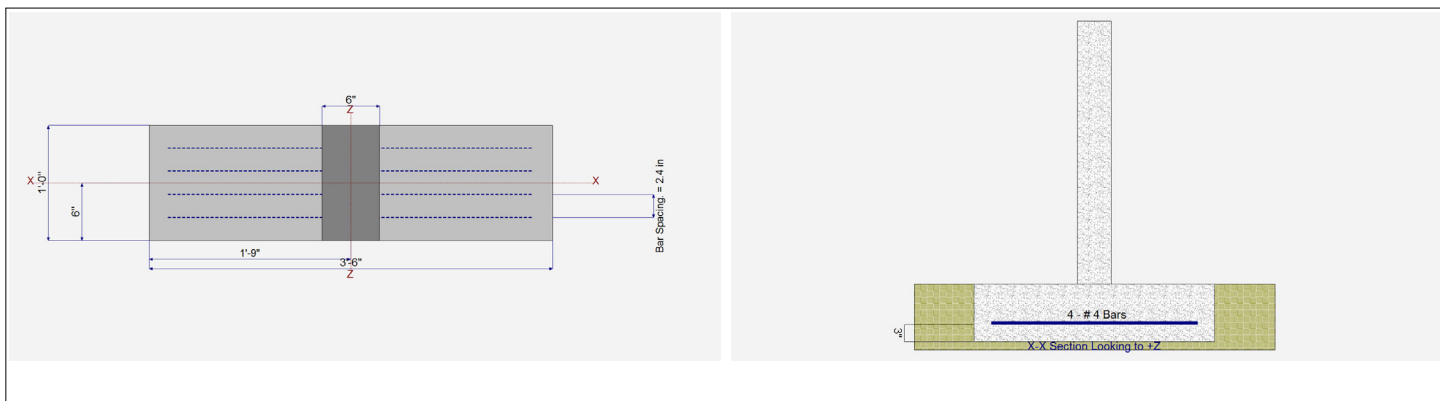

### Applied Loads

	D	Lr	L	S	W	E	H
P : Column Load	=	4.750					k
OB : Overburden	=						ksf
V-x	=						k
M-zz	=						k-ft
Vx applied	=		in	above top of footing			



**Wall Footing**

File = C:\Users\SBRADS-1\Desktop\2017-0\CALCUL-1\Enercalc.ec6  
ENERCALC, INC. 1983-2017, Build:10.17.9.13, Ver:10.17.9.13

Lic. # : KW-06007473

Licensee : SHAWN REEDER

Description : 42"x10" Ext Footing

**DESIGN SUMMARY**

**Design OK**

Factor of Safety	Item	Applied	Capacity	Governing Load Combination	
PASS	n/a	Overturning - Z-Z	0.0 k-ft	0.0 k-ft	No Overturning
PASS	n/a	Sliding - X-X	0.0 k	0.0 k	No Sliding
PASS	n/a	Uplift	0.0 k	0.0 k	No Uplift

Utilization Ratio	Item	Applied	Capacity	Governing Load Combination	
PASS	0.9853	Soil Bearing	1.478 ksf	1.50 ksf	+D+0.750L+0.750S+0.5
PASS	0.1067	Z Flexure (+X)	2.328 k-ft	21.812 k-ft	+1.40D+1.60H
PASS	0.06861	Z Flexure (-X)	1.496 k-ft	21.812 k-ft	+0.90D+E+0.90H
PASS	0.3065	1-way Shear (+X)	22.991 psi	75.0 psi	+1.40D+1.60H
PASS	0.3065	1-way Shear (-X)	22.991 psi	75.0 psi	+1.40D+1.60H

**Detailed Results**

**Soil Bearing**

Rotation Axis & Load Combination...	Gross Allowable	Xecc	Actual Soil Bearing Stress		Actual / Allowable Ratio
			-X	+X	
, +D+H	1.50 ksf	0.0 in	1.478 ksf	1.478 ksf	0.985
, +D+L+H	1.50 ksf	0.0 in	1.478 ksf	1.478 ksf	0.985
, +D+Lr+H	1.50 ksf	0.0 in	1.478 ksf	1.478 ksf	0.985
, +D+S+H	1.50 ksf	0.0 in	1.478 ksf	1.478 ksf	0.985
, +D+0.750Lr+0.750L+H	1.50 ksf	0.0 in	1.478 ksf	1.478 ksf	0.985
, +D+0.750L+0.750S+H	1.50 ksf	0.0 in	1.478 ksf	1.478 ksf	0.985
, +D+0.60W+H	1.50 ksf	0.0 in	1.478 ksf	1.478 ksf	0.985
, +D+0.70E+H	1.50 ksf	0.0 in	1.478 ksf	1.478 ksf	0.985
, +D+0.750Lr+0.750L+0.450W+H	1.50 ksf	0.0 in	1.478 ksf	1.478 ksf	0.985
, +D+0.750L+0.750S+0.450W+H	1.50 ksf	0.0 in	1.478 ksf	1.478 ksf	0.985
, +D+0.750L+0.750S+0.5250E+H	1.50 ksf	0.0 in	1.478 ksf	1.478 ksf	0.985
, +0.60D+0.60W+0.60H	1.50 ksf	0.0 in	0.8868 ksf	0.8868 ksf	0.591
, +0.60D+0.70E+0.60H	1.50 ksf	0.0 in	0.8868 ksf	0.8868 ksf	0.591

**Overturning Stability**

Units : k-ft

Rotation Axis & Load Combination...	Overturning Moment	Resisting Moment	Stability Ratio	Status
-------------------------------------	--------------------	------------------	-----------------	--------

Footing Has NO Overturning

**Sliding Stability**

Force Application Axis Load Combination...	Sliding Force	Resisting Force	Sliding SafetyRatio	Status
--	---------------	-----------------	---------------------	--------

Footing Has NO Sliding

**Footing Flexure**

Flexure Axis & Load Combination	Mu k-ft	Which Side ?	Tension @ Bot. or Top ?	As Req'd in^2	Gvrn. As in^2	Actual As in^2	Phi*Mn k-ft	Status
, +1.40D+1.60H	2.328	-X	Bottom	0.216	Min Temp %	0.8	21.812	OK
, +1.40D+1.60H	2.328	+X	Bottom	0.216	Min Temp %	0.8	21.812	OK
, +1.20D+0.50Lr+1.60L+1.60H	1.995	-X	Bottom	0.216	Min Temp %	0.8	21.812	OK
, +1.20D+0.50Lr+1.60L+1.60H	1.995	+X	Bottom	0.216	Min Temp %	0.8	21.812	OK
, +1.20D+1.60L+0.50S+1.60H	1.995	-X	Bottom	0.216	Min Temp %	0.8	21.812	OK
, +1.20D+1.60L+0.50S+1.60H	1.995	+X	Bottom	0.216	Min Temp %	0.8	21.812	OK
, +1.20D+1.60Lr+0.50L+1.60H	1.995	-X	Bottom	0.216	Min Temp %	0.8	21.812	OK
, +1.20D+1.60Lr+0.50L+1.60H	1.995	+X	Bottom	0.216	Min Temp %	0.8	21.812	OK
, +1.20D+1.60Lr+0.50W+1.60H	1.995	-X	Bottom	0.216	Min Temp %	0.8	21.812	OK
, +1.20D+1.60Lr+0.50W+1.60H	1.995	+X	Bottom	0.216	Min Temp %	0.8	21.812	OK
, +1.20D+1.60Lr+1.60S+1.60H	1.995	-X	Bottom	0.216	Min Temp %	0.8	21.812	OK
, +1.20D+1.60Lr+1.60S+1.60H	1.995	+X	Bottom	0.216	Min Temp %	0.8	21.812	OK
, +1.20D+1.60S+0.50W+1.60H	1.995	-X	Bottom	0.216	Min Temp %	0.8	21.812	OK
, +1.20D+1.60S+0.50W+1.60H	1.995	+X	Bottom	0.216	Min Temp %	0.8	21.812	OK
, +1.20D+0.50Lr+0.50L+W+1.60H	1.995	-X	Bottom	0.216	Min Temp %	0.8	21.812	OK
, +1.20D+0.50Lr+0.50L+W+1.60H	1.995	+X	Bottom	0.216	Min Temp %	0.8	21.812	OK
, +1.20D+0.50L+0.50S+W+1.60H	1.995	-X	Bottom	0.216	Min Temp %	0.8	21.812	OK
, +1.20D+0.50L+0.50S+W+1.60H	1.995	+X	Bottom	0.216	Min Temp %	0.8	21.812	OK



Performance Engineers  
1102 N. Franklin Blvd  
Nampa, ID 83687

Project Title:  
Engineer:  
Project Descr:

Project ID:

## Wall Footing

File = C:\Users\SBRADS-1\Desktop\2017-0\CALCUL-1\Enercalc.ec6  
ENERCALC, INC. 1983-2017, Build:10.17.9.13, Ver:10.17.9.13

Lic. # : KW-06007473

Licensee : SHAWN REEDER

Description : 42"x10" Ext Footing

, +1.20D+0.50L+0.70S+E+1.60H	1.995	-X	Bottom	0.216	Min Temp %	0.8	21.812	OK
, +1.20D+0.50L+0.70S+E+1.60H	1.995	+X	Bottom	0.216	Min Temp %	0.8	21.812	OK



Performance Engineers  
1102 N. Franklin Blvd  
Nampa, ID 83687

Project Title:  
Engineer:  
Project Descr:

Project ID:

**Wall Footing**

File = C:\Users\SBRADS~1\Desktop\2017-0\CALCUL~1\Enercalc.ec6  
ENERCALC, INC. 1983-2017, Build:10.17.9.13, Ver:10.17.9.13

Lic. # : KW-06007473

Licensee : SHAWN REEDER

Description : 42"x10" Ext Footing

**Footing Flexure**

Flexure Axis & Load Combination	Mu k-ft	Which Side ?	Tension @ Bot. or Top ?	As Req'd in^2	Gvrn. As in^2	Actual As in^2	Phi*Mn k-ft	Status
, +0.90D+W+0.90H	1.496	-X	Bottom	0.216	Min Temp %	0.8	21.812	OK
, +0.90D+W+0.90H	1.496	+X	Bottom	0.216	Min Temp %	0.8	21.812	OK
, +0.90D+E+0.90H	1.496	-X	Bottom	0.216	Min Temp %	0.8	21.812	OK
, +0.90D+E+0.90H	1.496	+X	Bottom	0.216	Min Temp %	0.8	21.812	OK

Units : k

**One Way Shear**

Load Combination...	Vu @ -X	Vu @ +X	Vu:Max	Phi Vn	Vu / Phi*Vn	Status
+1.40D+1.60H	22.991 psi	22.991 psi	22.991 psi	75 psi	0.3065	OK
+1.20D+0.50Lr+1.60L+1.60H	19.706 psi	19.706 psi	19.706 psi	75 psi	0.2628	OK
+1.20D+1.60L+0.50S+1.60H	19.706 psi	19.706 psi	19.706 psi	75 psi	0.2628	OK
+1.20D+1.60Lr+0.50L+1.60H	19.706 psi	19.706 psi	19.706 psi	75 psi	0.2628	OK
+1.20D+1.60Lr+0.50W+1.60H	19.706 psi	19.706 psi	19.706 psi	75 psi	0.2628	OK
+1.20D+0.50L+1.60S+1.60H	19.706 psi	19.706 psi	19.706 psi	75 psi	0.2628	OK
+1.20D+1.60S+0.50W+1.60H	19.706 psi	19.706 psi	19.706 psi	75 psi	0.2628	OK
+1.20D+0.50Lr+0.50L+W+1.60H	19.706 psi	19.706 psi	19.706 psi	75 psi	0.2628	OK
+1.20D+0.50L+0.50S+W+1.60H	19.706 psi	19.706 psi	19.706 psi	75 psi	0.2628	OK
+1.20D+0.50L+0.70S+E+1.60H	19.706 psi	19.706 psi	19.706 psi	75 psi	0.2628	OK
+0.90D+W+0.90H	14.78 psi	14.78 psi	14.78 psi	75 psi	0.1971	OK
+0.90D+E+0.90H	14.78 psi	14.78 psi	14.78 psi	75 psi	0.1971	OK



## Beam on Elastic Foundation

Lic. # : KW-06007473

Licensee : SHAWN REEDER

Description : Truss Braced Frame

### CODE REFERENCES

Calculations per ACI 318-14, IBC 2015, CBC 2016, ASCE 7-10

Load Combinations Used : IBC 2018

### Material Properties

$f'_c$	=	2.50 ksi	$\phi$ Phi Values	Flexure :	0.90
$f_r = f'_c^{1/2} * 7.50$	=	psi		Shear :	0.750
$\Psi$ Density	=	145.0 pcf	$\beta_1$	=	
$\lambda$ Lt Wt Factor	=	1.0			
Elastic Modulus	=	3,122.0 ksi			
Soil Subgrade Modulus	=	250.0 psi / (inch deflection)			

Load Combination IBC 2018

$f_y$ - Main Rebar	=	60.0 ksi	$F_y$ - Stirrups	=	40.0 ksi
E - Main Rebar	=	29,000.0 ksi	E - Stirrups	=	29,000.0 ksi
			Stirrup Bar Size #	=	# 3
			Number of Resisting Legs Per Stirrup	=	2

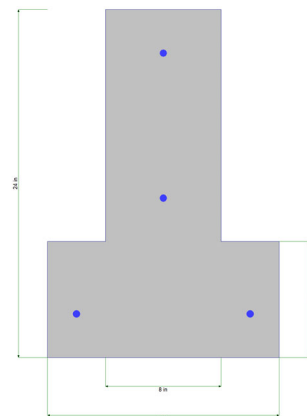

Beam is supported on an elastic foundation.

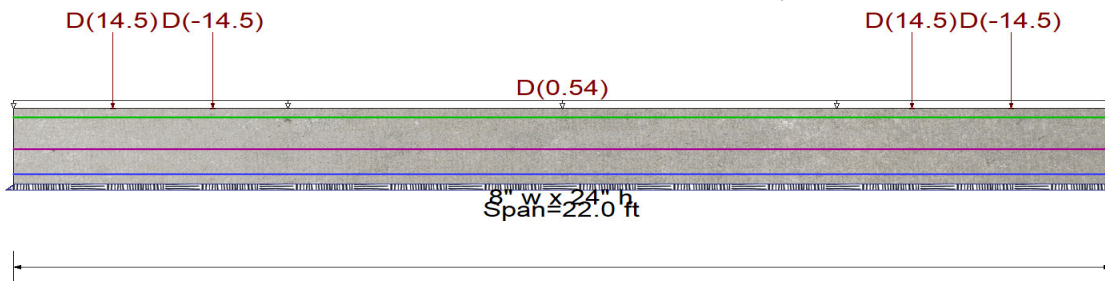

### Cross Section & Reinforcing Details

Inverted Tee Section, Stem Width = 8.0 in, Total Height = 24.0 in, Top Flange Width = 16.0 in, Flange Thickness = 8.0 in

Span #1 Reinforcing....

2-#4 at 3.0 in from Bottom, from 0.0 to 22.0 ft in this span  
1-#4 at 11.0 in from Bottom, from 0.0 to 22.0 ft in this span

1-#4 at 3.0 in from Top, from 0.0 to 22.0 ft in this span

### Applied Loads

Service loads entered. Load Factors will be applied for calculations.

### Beam self weight calculated and added to loads

Point Load : D = 14.50 k @ 2.0 ft  
Point Load : D = 14.50 k @ 18.0 ft  
Point Load : D = -14.50 k @ 4.0 ft  
Point Load : D = -14.50 k @ 20.0 ft  
Uniform Load : D = 0.540 k/ft, Tributary Width = 1.0 ft

### DESIGN SUMMARY

Design OK

Maximum Bending Stress Ratio =	<b>0.970 : 1</b>	Maximum Deflection	
Section used for this span	<b>Typical Section</b>	Max Downward L+Lr+S Deflection	0.000 in
Mu : Applied	-30.720 k-ft	Max Upward L+Lr+S Deflection	0.000 in
Mn * Phi : Allowable	31.659 k-ft	Max Downward Total Deflection	0.039 in
Load Combination	+1.40D+1.60H	Max Upward Total Deflection	-0.006 in
Location of maximum on span	4.141 ft		
Span # where maximum occurs	Span # 1		

Maximum Soil Pressure = 1.419 ksf at 0.00 ft LdComb: +D+H  
Allowable Soil Pressure = 1.50 ksf OK

### Shear Stirrup Requirements

Between 0.00 to 1.81 ft,  $V_u < \Phi V_c/2$ , Req'd Vs = Not Reqd, use stirrups spaced at 0.000 in  
Between 2.07 to 3.88 ft,  $V_u > \Phi V_c$ , Req'd Vs = 2.770, use stirrups spaced at 10.500 in  
Between 4.14 to 17.86 ft,  $V_u < \Phi V_c/2$ , Req'd Vs = Not Reqd, use stirrups spaced at 0.000 in  
Between 18.12 to 19.93 ft,  $V_u > \Phi V_c$ , Req'd Vs = 4.241, use stirrups spaced at 10.500 in  
Between 20.19 to 21.48 ft,  $V_u < \Phi V_c/2$ , Req'd Vs = Not Reqd, use stirrups spaced at 6.000 in



Performance Engineers  
1102 N. Franklin Blvd  
Nampa, ID 83687

Project Title:  
Engineer:  
Project ID:  
Project Descr:

## Beam on Elastic Foundation

File = U:\Desktop\Folders\2018-0\CALCUL-1107 Foundation.ec6 .  
Software copyright ENERCALC, INC. 1983-2018, Build:10.18.11.30 .

Lic. # : KW-06007473

Licensee : SHAWN REEDER

Description : Truss Braced Frame

### Maximum Forces & Stresses for Load Combinations

Load Combination	Segment Length	Span #	Location (ft) in Span	Bending Stress Results (k-ft)		
				Mu : Max	Phi*Mnx	Stress Ratio
MAXimum Bending Envelope						
Span # 1		1	17.859	30.72	46.78	0.66
+1.40D+1.60H						
Span # 1		1	17.859	30.72	46.78	0.66
+1.20D+0.50Lr+1.60L+1.60H						
Span # 1		1	17.859	26.33	46.78	0.56
+1.20D+1.60L+0.50S+1.60H						
Span # 1		1	17.859	26.33	46.78	0.56
+1.20D+1.60Lr+0.50L+1.60H						
Span # 1		1	17.859	26.33	46.78	0.56
+1.20D+1.60Lr+0.50W+1.60H						
Span # 1		1	17.859	26.33	46.78	0.56
+1.20D+0.50L+1.60S+1.60H						
Span # 1		1	17.859	26.33	46.78	0.56
+1.20D+1.60S+0.50W+1.60H						
Span # 1		1	17.859	26.33	46.78	0.56
+1.20D+0.50Lr+0.50L+W+1.60H						
Span # 1		1	17.859	26.33	46.78	0.56
+1.20D+0.50L+0.50S+W+1.60H						
Span # 1		1	17.859	26.33	46.78	0.56
+1.20D+0.50L+0.70S+E+1.60H						
Span # 1		1	17.859	26.33	46.78	0.56
+0.90D+W+0.90H						
Span # 1		1	17.859	19.75	46.78	0.42
+0.90D+E+0.90H						
Span # 1		1	17.859	19.75	46.78	0.42

### Overall Maximum Deflections - Unfactored Loads

Load Combination	Span	Max. "-" Defl	Location in Span	Load Combination	Max. "+" Defl	Location in Span
Span 1	1	0.0394	0.000	Span 1	-0.0062	22.000

### Detailed Shear Information

Load Combination	Span Number	Distance (ft)	'd' (in)	Vu (k)		Mu (k-ft)	d*Vu/Mu	Phi*Vc (k)	Comment	Phi*Vs (k)	Spacing (in)	
				Actual	Design						Req'd	Suggest
+1.40D+1.60H	1	0.00	21.00	0.33	0.33	0.00	1.00	13.47	Vu < PhiVc/2	Not Reqd	0.00	0.00
+1.40D+1.60H	1	0.26	21.00	0.71	0.71	0.05	1.00	13.47	Vu < PhiVc/2	Not Reqd	0.00	0.00
+1.40D+1.60H	1	0.52	21.00	1.07	1.07	0.20	1.00	13.47	Vu < PhiVc/2	Not Reqd	0.00	0.00
+1.40D+1.60H	1	0.78	21.00	1.41	1.41	0.44	1.00	13.47	Vu < PhiVc/2	Not Reqd	0.00	0.00
+1.40D+1.60H	1	1.04	21.00	1.73	1.73	0.77	1.00	13.47	Vu < PhiVc/2	Not Reqd	0.00	0.00
+1.40D+1.60H	1	1.29	21.00	2.04	2.04	1.19	1.00	13.47	Vu < PhiVc/2	Not Reqd	0.00	0.00
+1.40D+1.60H	1	1.55	21.00	2.32	2.32	1.68	1.00	13.47	Vu < PhiVc/2	Not Reqd	0.00	0.00
+1.40D+1.60H	1	1.81	21.00	2.59	2.59	2.25	1.00	13.47	Vu < PhiVc/2	Not Reqd	0.00	0.00
+1.40D+1.60H	1	2.07	21.00	-17.46	17.46	1.45	1.00	13.47	Vu > PhiVc	3.994	0.00	10.50
+1.40D+1.60H	1	2.33	21.00	-17.23	17.23	3.10	1.00	13.47	Vu > PhiVc	3.765	0.00	10.50
+1.40D+1.60H	1	2.59	21.00	-17.02	17.02	7.60	1.00	13.47	Vu > PhiVc	3.555	0.00	10.50
+1.40D+1.60H	1	2.85	21.00	-16.83	16.83	12.04	1.00	13.47	Vu > PhiVc	3.363	0.00	10.50
+1.40D+1.60H	1	3.11	21.00	-16.66	16.66	16.43	1.00	13.47	Vu > PhiVc	3.189	0.00	10.50
+1.40D+1.60H	1	3.36	21.00	-16.50	16.50	20.77	1.00	13.47	Vu > PhiVc	3.033	0.00	10.50
+1.40D+1.60H	1	3.62	21.00	-16.36	16.36	25.08	1.00	13.47	Vu > PhiVc	2.893	0.00	10.50
+1.40D+1.60H	1	3.88	21.00	-16.24	16.24	29.35	1.00	13.47	Vu > PhiVc	2.770	0.00	10.50
+1.40D+1.60H	1	4.14	21.00	4.17	4.17	30.72	1.00	13.47	Vu < PhiVc/2	Not Reqd	0.00	0.00
+1.40D+1.60H	1	4.40	21.00	4.27	4.27	29.67	1.00	13.47	Vu < PhiVc/2	Not Reqd	0.00	0.00
+1.40D+1.60H	1	4.66	21.00	4.35	4.35	28.60	1.00	13.47	Vu < PhiVc/2	Not Reqd	0.00	0.00
+1.40D+1.60H	1	4.92	21.00	4.42	4.42	27.51	1.00	13.47	Vu < PhiVc/2	Not Reqd	0.00	0.00
+1.40D+1.60H	1	5.18	21.00	4.48	4.48	26.40	1.00	13.47	Vu < PhiVc/2	Not Reqd	0.00	0.00
+1.40D+1.60H	1	5.44	21.00	4.53	4.53	25.28	1.00	13.47	Vu < PhiVc/2	Not Reqd	0.00	0.00
+1.40D+1.60H	1	5.69	21.00	4.58	4.58	24.14	1.00	13.47	Vu < PhiVc/2	Not Reqd	0.00	0.00
+1.40D+1.60H	1	5.95	21.00	4.61	4.61	22.99	1.00	13.47	Vu < PhiVc/2	Not Reqd	0.00	0.00
+1.40D+1.60H	1	6.21	21.00	4.64	4.64	21.83	1.00	13.47	Vu < PhiVc/2	Not Reqd	0.00	0.00
+1.40D+1.60H	1	6.47	21.00	4.66	4.66	20.67	1.00	13.47	Vu < PhiVc/2	Not Reqd	0.00	0.00
+1.40D+1.60H	1	6.73	21.00	4.68	4.68	19.49	1.00	13.47	Vu < PhiVc/2	Not Reqd	0.00	0.00



Performance Engineers  
1102 N. Franklin Blvd  
Nampa, ID 83687

Project Title:  
Engineer:  
Project ID:  
Project Descr.:

**Beam on Elastic Foundation**

File = U:\Desktop\Folders\2018-0\CALCUL-1107 Foundation.ec6 .  
Software copyright ENERCALC, INC. 1983-2018, Build:10.18.11.30 .

Lic. # : KW-06007473

Licensee : SHAWN REEDER

Description : Truss Braced Frame

**Detailed Shear Information**

Load Combination	Span Number	Distance (ft)	'd' (in)	Vu (k)		Mu (k-ft)	d*Vu/Mu	Phi*Vc (k)	Comment	Phi*Vs (k)	Spacing (in)	
				Actual	Design						Req'd	Suggest
+1.40D+1.60H	1	6.99	21.00	4.69	4.69	18.31	1.00	13.47	Vu < PhiVc/2	Not Req'd	0.00	0.00
+1.40D+1.60H	1	7.25	21.00	4.70	4.70	17.13	1.00	13.47	Vu < PhiVc/2	Not Req'd	0.00	0.00
+1.40D+1.60H	1	7.51	21.00	4.71	4.71	15.95	1.00	13.47	Vu < PhiVc/2	Not Req'd	0.00	0.00
+1.40D+1.60H	1	7.76	21.00	4.71	4.71	14.77	1.00	13.47	Vu < PhiVc/2	Not Req'd	0.00	0.00
+1.40D+1.60H	1	8.02	21.00	4.71	4.71	13.58	1.00	13.47	Vu < PhiVc/2	Not Req'd	0.00	0.00
+1.40D+1.60H	1	8.28	21.00	4.71	4.71	12.40	1.00	13.47	Vu < PhiVc/2	Not Req'd	0.00	0.00
+1.40D+1.60H	1	8.54	21.00	4.70	4.70	11.21	1.00	13.47	Vu < PhiVc/2	Not Req'd	0.00	0.00
+1.40D+1.60H	1	8.80	21.00	4.70	4.70	10.03	1.00	13.47	Vu < PhiVc/2	Not Req'd	0.00	0.00
+1.40D+1.60H	1	9.06	21.00	4.70	4.70	8.85	1.00	13.47	Vu < PhiVc/2	Not Req'd	0.00	0.00
+1.40D+1.60H	1	9.32	21.00	4.69	4.69	7.66	1.00	13.47	Vu < PhiVc/2	Not Req'd	0.00	0.00
+1.40D+1.60H	1	9.58	21.00	4.69	4.69	6.48	1.00	13.47	Vu < PhiVc/2	Not Req'd	0.00	0.00
+1.40D+1.60H	1	9.84	21.00	4.69	4.69	5.30	1.00	13.47	Vu < PhiVc/2	Not Req'd	0.00	0.00
+1.40D+1.60H	1	10.09	21.00	4.68	4.68	4.13	1.00	13.47	Vu < PhiVc/2	Not Req'd	0.00	0.00
+1.40D+1.60H	1	10.35	21.00	4.68	4.68	2.95	1.00	13.47	Vu < PhiVc/2	Not Req'd	0.00	0.00
+1.40D+1.60H	1	10.61	21.00	4.68	4.68	1.77	1.00	13.47	Vu < PhiVc/2	Not Req'd	0.00	0.00
+1.40D+1.60H	1	10.87	21.00	4.68	4.68	0.59	1.00	13.47	Vu < PhiVc/2	Not Req'd	0.00	0.00
+1.40D+1.60H	1	11.13	21.00	4.68	4.68	0.58	1.00	13.47	Vu < PhiVc/2	Not Req'd	0.00	0.00
+1.40D+1.60H	1	11.39	21.00	4.68	4.68	1.76	1.00	13.47	Vu < PhiVc/2	Not Req'd	0.00	0.00
+1.40D+1.60H	1	11.65	21.00	4.68	4.68	2.94	1.00	13.47	Vu < PhiVc/2	Not Req'd	0.00	0.00
+1.40D+1.60H	1	11.91	21.00	4.69	4.69	4.12	1.00	13.47	Vu < PhiVc/2	Not Req'd	0.00	0.00
+1.40D+1.60H	1	12.16	21.00	4.69	4.69	5.30	1.00	13.47	Vu < PhiVc/2	Not Req'd	0.00	0.00
+1.40D+1.60H	1	12.42	21.00	4.69	4.69	6.48	1.00	13.47	Vu < PhiVc/2	Not Req'd	0.00	0.00
+1.40D+1.60H	1	12.68	21.00	4.70	4.70	7.66	1.00	13.47	Vu < PhiVc/2	Not Req'd	0.00	0.00
+1.40D+1.60H	1	12.94	21.00	4.70	4.70	8.84	1.00	13.47	Vu < PhiVc/2	Not Req'd	0.00	0.00
+1.40D+1.60H	1	13.20	21.00	4.70	4.70	10.02	1.00	13.47	Vu < PhiVc/2	Not Req'd	0.00	0.00
+1.40D+1.60H	1	13.46	21.00	4.71	4.71	11.21	1.00	13.47	Vu < PhiVc/2	Not Req'd	0.00	0.00
+1.40D+1.60H	1	13.72	21.00	4.71	4.71	12.39	1.00	13.47	Vu < PhiVc/2	Not Req'd	0.00	0.00
+1.40D+1.60H	1	13.98	21.00	4.71	4.71	13.58	1.00	13.47	Vu < PhiVc/2	Not Req'd	0.00	0.00
+1.40D+1.60H	1	14.24	21.00	4.71	4.71	14.76	1.00	13.47	Vu < PhiVc/2	Not Req'd	0.00	0.00
+1.40D+1.60H	1	14.49	21.00	4.70	4.70	15.94	1.00	13.47	Vu < PhiVc/2	Not Req'd	0.00	0.00
+1.40D+1.60H	1	14.75	21.00	4.69	4.69	17.13	1.00	13.47	Vu < PhiVc/2	Not Req'd	0.00	0.00
+1.40D+1.60H	1	15.01	21.00	4.68	4.68	18.31	1.00	13.47	Vu < PhiVc/2	Not Req'd	0.00	0.00
+1.40D+1.60H	1	15.27	21.00	4.66	4.66	19.48	1.00	13.47	Vu < PhiVc/2	Not Req'd	0.00	0.00
+1.40D+1.60H	1	15.53	21.00	4.64	4.64	20.66	1.00	13.47	Vu < PhiVc/2	Not Req'd	0.00	0.00
+1.40D+1.60H	1	15.79	21.00	4.61	4.61	21.82	1.00	13.47	Vu < PhiVc/2	Not Req'd	0.00	0.00
+1.40D+1.60H	1	16.05	21.00	4.58	4.58	22.98	1.00	13.47	Vu < PhiVc/2	Not Req'd	0.00	0.00
+1.40D+1.60H	1	16.31	21.00	4.53	4.53	24.13	1.00	13.47	Vu < PhiVc/2	Not Req'd	0.00	0.00
+1.40D+1.60H	1	16.56	21.00	4.48	4.48	25.27	1.00	13.47	Vu < PhiVc/2	Not Req'd	0.00	0.00
+1.40D+1.60H	1	16.82	21.00	4.42	4.42	26.40	1.00	13.47	Vu < PhiVc/2	Not Req'd	0.00	0.00
+1.40D+1.60H	1	17.08	21.00	4.35	4.35	27.51	1.00	13.47	Vu < PhiVc/2	Not Req'd	0.00	0.00
+1.40D+1.60H	1	17.34	21.00	4.27	4.27	28.60	1.00	13.47	Vu < PhiVc/2	Not Req'd	0.00	0.00
+1.40D+1.60H	1	17.60	21.00	4.17	4.17	29.67	1.00	13.47	Vu < PhiVc/2	Not Req'd	0.00	0.00
+1.40D+1.60H	1	17.86	21.00	4.06	4.06	30.72	1.00	13.47	Vu < PhiVc/2	Not Req'd	0.00	0.00
+1.40D+1.60H	1	18.12	21.00	-16.36	16.36	29.35	1.00	13.47	Vu > PhiVc	2.892	0.00	10.50
+1.40D+1.60H	1	18.38	21.00	-16.50	16.50	25.08	1.00	13.47	Vu > PhiVc	3.032	0.00	10.50
+1.40D+1.60H	1	18.64	21.00	-16.66	16.66	20.77	1.00	13.47	Vu > PhiVc	3.188	0.00	10.50
+1.40D+1.60H	1	18.89	21.00	-16.83	16.83	16.43	1.00	13.47	Vu > PhiVc	3.362	0.00	10.50
+1.40D+1.60H	1	19.15	21.00	-17.02	17.02	12.04	1.00	13.47	Vu > PhiVc	3.554	0.00	10.50
+1.40D+1.60H	1	19.41	21.00	-17.23	17.23	7.60	1.00	13.47	Vu > PhiVc	3.764	0.00	10.50
+1.40D+1.60H	1	19.67	21.00	-17.46	17.46	3.10	1.00	13.47	Vu > PhiVc	3.993	0.00	10.50
+1.40D+1.60H	1	19.93	21.00	-17.71	17.71	1.45	1.00	13.47	Vu > PhiVc	4.241	0.00	10.50
+1.40D+1.60H	1	20.19	21.00	2.32	2.32	2.25	1.00	13.47	Vu < PhiVc/2	Not Req'd	0.00	0.00
+1.40D+1.60H	1	20.45	21.00	2.04	2.04	1.68	1.00	13.47	Vu < PhiVc/2	Not Req'd	0.00	0.00
+1.40D+1.60H	1	20.71	21.00	1.73	1.73	1.19	1.00	13.47	Vu < PhiVc/2	Not Req'd	0.00	0.00



Performance Engineers  
 1102 N. Franklin Blvd  
 Nampa, ID 83687

Project Title:  
 Engineer:  
 Project ID:  
 Project Descr:

**Beam on Elastic Foundation**

File = U:\Desktop\Folders\2018-0\CALCUL-1107 Foundation.ec6 .  
 Software copyright ENERCALC, INC. 1983-2018, Build:10.18.11.30 .

Lic. # : KW-06007473

Licensee : SHAWN REEDER

Description : Truss Braced Frame

**Detailed Shear Information**

Load Combination	Span Number	Distance (ft)	'd' (in)	Vu (k)		Mu (k-ft)	d*Vu/Mu	Phi*Vc (k)	Comment	Phi*Vs (k)	Spacing (in)	
				Actual	Design						Req'd	Suggest
+1.40D+1.60H	1	20.96	21.00	1.41	1.41	0.77	1.00	13.47	Vu < PhiVc/2	Not Reqd	0.00	0.00
+1.40D+1.60H	1	21.22	21.00	1.07	1.07	0.44	1.00	13.47	Vu < PhiVc/2	Not Reqd	0.00	0.00
+1.40D+1.60H	1	21.48	21.00	0.71	0.71	0.20	1.00	13.47	Vu < PhiVc/2	Not Reqd	0.00	0.00
+1.40D+1.60H	1	21.74	21.00	0.33	0.33	0.05	1.00	13.47	Vu < PhiVc/2	Not Reqd	0.00	0.00

## Beam on Elastic Foundation

File = U:\Desktop\Folders\2018-0\CALCUL-1107 Foundation.ec6 .  
Software copyright ENERCALC, INC. 1983-2018, Build:10.18.11.30 .

Lic. # : KW-06007473

License : SHAWN REEDER

Description : Garage door foundation loading

### CODE REFERENCES

Calculations per ACI 318-14, IBC 2015, CBC 2016, ASCE 7-10

Load Combinations Used : IBC 2015

### Material Properties

$f'_c$	=	2.50 ksi	$\phi$ Phi Values	Flexure :	0.90
$f_r = f'_c^{1/2} * 7.50$	=	375.0 psi		Shear :	0.750
$\Psi$ Density	=	145.0 pcf	$\beta_1$	=	0.850
$\lambda$ Lt Wt Factor	=	1.0			
Elastic Modulus	=	3,122.0 ksi			
Soil Subgrade Modulus	=	250.0 psi / (inch deflection)			

Load Combination IBC 2015

$f_y$ - Main Rebar	=	60.0 ksi	$F_y$ - Stirrups	=	40.0 ksi
E - Main Rebar	=	29,000.0 ksi	E - Stirrups	=	29,000.0 ksi
			Stirrup Bar Size #	=	# 3
			Number of Resisting Legs Per Stirrup	=	2

Beam is supported on an elastic foundation.

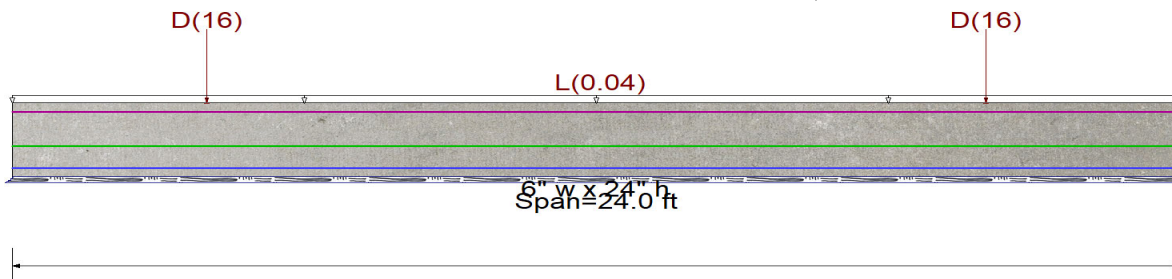
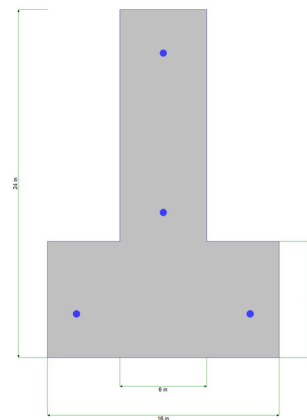

### Cross Section & Reinforcing Details

Inverted Tee Section, Stem Width = 6.0 in, Total Height = 24.0 in, Top Flange Width = 16.0 in, Flange Thickness = 8.0 in

Span #1 Reinforcing....

2-#4 at 3.0 in from Bottom, from 0.0 to 24.0 ft in this span

1-#4 at 10.0 in from Bottom, from 0.0 to 24.0 ft in this span

1-#4 at 3.0 in from Top, from 0.0 to 24.0 ft in this span

### Applied Loads

Service loads entered. Load Factors will be applied for calculations.

Point Load : D = 16.0 k @ 4.0 ft

Point Load : D = 16.0 k @ 20.0 ft

Uniform Load : L = 0.040 k/ft, Tributary Width = 1.0 ft

### DESIGN SUMMARY

**Design OK**

Maximum Bending Stress Ratio =	<b>0.695</b> : 1
Section used for this span	<b>Typical Section</b>
Mu : Applied	-21.376 k-ft
Mn * Phi : Allowable	30.759 k-ft
Load Combination	+1.40D+1.60H
Location of maximum on span	11.859 ft
Span # where maximum occurs	Span # 1

Maximum Deflection	
Max Downward L+Lr+S Deflection	0.000 in
Max Upward L+Lr+S Deflection	0.000 in
Max Downward Total Deflection	0.041 in
Max Upward Total Deflection	0.000 in

Maximum Soil Pressure =	1.492 ksf	at	24.00 ft	LdComb: +D+L+H
Allowable Soil Pressure =	1.50 ksf	OK		

### Shear Stirrup Requirements

Between 0.00 to 3.95 ft,  $\Phi V_c/2 < V_u \leq \Phi V_c$ , Req'd Vs = Not Reqd 11.5.6.1, use stirrups spaced at 0.000 in  
 Between 4.24 to 4.52 ft,  $V_u > \Phi V_c$ , Req'd Vs = 0.3632, use stirrups spaced at 10.500 in  
 Between 4.80 to 18.92 ft,  $\Phi V_c/2 < V_u \leq \Phi V_c$ , Req'd Vs = Not Reqd 11.5.6.1, use stirrups spaced at 0.000 in  
 Between 19.20 to 19.76 ft,  $V_u > \Phi V_c$ , Req'd Vs = 1.610, use stirrups spaced at 10.500 in  
 Between 20.05 to 23.44 ft,  $V_u < \Phi V_c/2$ , Req'd Vs = Not Reqd, use stirrups spaced at 0.000 in

### Maximum Forces & Stresses for Load Combinations



Performance Engineers  
1102 N. Franklin Blvd  
Nampa, ID 83687

Project Title:  
Engineer:  
Project ID:  
Project Descr:

### Beam on Elastic Foundation

File = U:\Desktop\Folders\2018-0\CALCUL-1107 Foundation.ec6 .  
Software copyright ENERCALC, INC. 1983-2018, Build:10.18.11.30 .

Lic. # : KW-06007473

Licensee : SHAWN REEDER

Description : Garage door foundation loading

Load Combination	Segment Length	Span #	Location (ft) in Span	Bending Stress Results (k-ft)		
				Mu : Max	Phi*Mnx	Stress Ratio
MAXimum Bending Envelope						
Span # 1		1	20.047	20.32	46.57	0.44
+1.40D+1.60H						
Span # 1		1	20.047	20.32	46.57	0.44
+1.20D+0.50Lr+1.60L+1.60H						
Span # 1		1	20.047	17.42	46.57	0.37
+1.20D+1.60L+0.50S+1.60H						
Span # 1		1	20.047	17.42	46.57	0.37
+1.20D+1.60Lr+0.50L+1.60H						
Span # 1		1	20.047	17.42	46.57	0.37
+1.20D+1.60Lr+0.50W+1.60H						
Span # 1		1	20.047	17.42	46.57	0.37
+1.20D+0.50L+1.60S+1.60H						
Span # 1		1	20.047	17.42	46.57	0.37
+1.20D+1.60S+0.50W+1.60H						
Span # 1		1	20.047	17.42	46.57	0.37
+1.20D+0.50Lr+0.50L+W+1.60H						
Span # 1		1	20.047	17.42	46.57	0.37
+1.20D+0.50L+0.50S+W+1.60H						
Span # 1		1	20.047	17.42	46.57	0.37
+1.20D+0.50L+0.70S+E+1.60H						
Span # 1		1	20.047	17.42	46.57	0.37
+0.90D+W+0.90H						
Span # 1		1	20.047	13.06	46.57	0.28
+0.90D+E+0.90H						
Span # 1		1	20.047	13.06	46.57	0.28

### Overall Maximum Deflections - Unfactored Loads

Load Combination	Span	Max. "-" Defl	Location in Span	Load Combination	Max. "+" Defl	Location in Span
Span 1	1	0.0414	24.000		0.0000	0.000

### Detailed Shear Information

Load Combination	Span Number	Distance (ft)	'd' (in)	Vu (k)		Mu (k-ft)	d*Vu/Mu	Phi*Vc (k)	Comment	Phi*Vs (k)	Spacing (in)	
				Actual	Design						Req'd	Suggest
+1.40D+1.60H	1	0.00	21.00	0.39	0.39	0.00	1.00	10.48	Vu < PhiVc/2	Not Reqd	0.00	0.00
+1.40D+1.60H	1	0.28	21.00	1.15	1.15	0.11	1.00	10.48	Vu < PhiVc/2	Not Reqd	0.00	0.00
+1.40D+1.60H	1	0.56	21.00	1.90	1.90	0.43	1.00	10.48	Vu < PhiVc/2	Not Reqd	0.00	0.00
+1.40D+1.60H	1	0.85	21.00	2.65	2.65	0.97	1.00	10.48	Vu < PhiVc/2	Not Reqd	0.00	0.00
+1.40D+1.60H	1	1.13	21.00	3.39	3.39	1.72	1.00	10.48	Vu < PhiVc/2	Not Reqd	0.00	0.00
+1.40D+1.60H	1	1.41	21.00	4.13	4.13	2.68	1.00	10.48	Vu < PhiVc/2	Not Reqd	0.00	0.00
+1.40D+1.60H	1	1.69	21.00	4.85	4.85	3.84	1.00	10.48	Vu < PhiVc/2	Not Reqd	0.00	0.00
+1.40D+1.60H	1	1.98	21.00	5.57	5.57	5.21	1.00	10.48	PhiVc/2 < Vu <=	Not Reqd 1	0.00	0.00
+1.40D+1.60H	1	2.26	21.00	6.27	6.27	6.78	1.00	10.48	PhiVc/2 < Vu <=	Not Reqd 1	0.00	0.00
+1.40D+1.60H	1	2.54	21.00	6.97	6.97	8.56	1.00	10.48	PhiVc/2 < Vu <=	Not Reqd 1	0.00	0.00
+1.40D+1.60H	1	2.82	21.00	7.66	7.66	10.53	1.00	10.48	PhiVc/2 < Vu <=	Not Reqd 1	0.00	0.00
+1.40D+1.60H	1	3.11	21.00	8.34	8.34	12.69	1.00	10.48	PhiVc/2 < Vu <=	Not Reqd 1	0.00	0.00
+1.40D+1.60H	1	3.39	21.00	9.01	9.01	15.04	1.00	10.48	PhiVc/2 < Vu <=	Not Reqd 1	0.00	0.00
+1.40D+1.60H	1	3.67	21.00	9.67	9.67	17.59	1.00	10.48	PhiVc/2 < Vu <=	Not Reqd 1	0.00	0.00
+1.40D+1.60H	1	3.95	21.00	10.31	10.31	20.32	1.00	10.48	PhiVc/2 < Vu <=	Not Reqd 1	0.00	0.00
+1.40D+1.60H	1	4.24	21.00	-11.46	11.46	17.96	1.00	10.48	Vu > PhiVc	0.9795	0.00	10.50
+1.40D+1.60H	1	4.52	21.00	-10.84	10.84	14.72	1.00	10.48	Vu > PhiVc	0.3632	0.00	10.50
+1.40D+1.60H	1	4.80	21.00	-10.24	10.24	11.66	1.00	10.48	PhiVc/2 < Vu <=	Not Reqd 1	0.00	0.00
+1.40D+1.60H	1	5.08	21.00	-9.66	9.66	8.77	1.00	10.48	PhiVc/2 < Vu <=	Not Reqd 1	0.00	0.00
+1.40D+1.60H	1	5.36	21.00	-9.09	9.09	6.05	1.00	10.48	PhiVc/2 < Vu <=	Not Reqd 1	0.00	0.00
+1.40D+1.60H	1	5.65	21.00	-8.54	8.54	3.48	1.00	10.48	PhiVc/2 < Vu <=	Not Reqd 1	0.00	0.00
+1.40D+1.60H	1	5.93	21.00	-8.00	8.00	1.07	1.00	10.48	PhiVc/2 < Vu <=	Not Reqd 1	0.00	0.00
+1.40D+1.60H	1	6.21	21.00	-7.49	7.49	1.19	1.00	10.48	PhiVc/2 < Vu <=	Not Reqd 1	0.00	0.00
+1.40D+1.60H	1	6.49	21.00	-6.99	6.99	3.30	1.00	10.48	PhiVc/2 < Vu <=	Not Reqd 1	0.00	0.00
+1.40D+1.60H	1	6.78	21.00	-6.51	6.51	5.28	1.00	10.48	PhiVc/2 < Vu <=	Not Reqd 1	0.00	0.00
+1.40D+1.60H	1	7.06	21.00	-6.04	6.04	7.11	1.00	10.48	PhiVc/2 < Vu <=	Not Reqd 1	0.00	0.00
+1.40D+1.60H	1	7.34	21.00	-5.59	5.59	11.91	1.00	10.48	PhiVc/2 < Vu <=	Not Reqd 1	0.00	0.00
+1.40D+1.60H	1	7.62	21.00	-5.16	5.16	10.40	1.00	10.48	Vu < PhiVc/2	Not Reqd	0.00	0.00



Performance Engineers  
1102 N. Franklin Blvd  
Nampa, ID 83687

Project Title:  
Engineer:  
Project ID:  
Project Descr.:

### Beam on Elastic Foundation

File = U:\Desktop\Folders\2018-0\CALCUL-1107 Foundation.ec6 .  
Software copyright ENERCALC, INC. 1983-2018, Build:10.18.11.30 .

Lic. # : KW-06007473

Licensee : SHAWN REEDER

Description : Garage door foundation loading

#### Detailed Shear Information

Load Combination	Span Number	Distance (ft)	'd' (in)	Vu (k)		Mu (k-ft)	d*Vu/Mu	Phi*Vc (k)	Comment	Phi*Vs (k)	Spacing (in)	
				Actual	Design						Req'd	Suggest
+1.40D+1.60H	1	7.91	21.00	-4.74	4.74	11.85	1.00	10.48	Vu < PhiVc/2	Not Req'd	0.00	0.00
+1.40D+1.60H	1	8.19	21.00	-4.34	4.34	13.19	1.00	10.48	Vu < PhiVc/2	Not Req'd	0.00	0.00
+1.40D+1.60H	1	8.47	21.00	-3.95	3.95	14.42	1.00	10.48	Vu < PhiVc/2	Not Req'd	0.00	0.00
+1.40D+1.60H	1	8.75	21.00	-3.57	3.57	15.53	1.00	10.48	Vu < PhiVc/2	Not Req'd	0.00	0.00
+1.40D+1.60H	1	9.04	21.00	-3.20	3.20	16.54	1.00	10.48	Vu < PhiVc/2	Not Req'd	0.00	0.00
+1.40D+1.60H	1	9.32	21.00	-2.85	2.85	17.44	1.00	10.48	Vu < PhiVc/2	Not Req'd	0.00	0.00
+1.40D+1.60H	1	9.60	21.00	-2.51	2.51	18.25	1.00	10.48	Vu < PhiVc/2	Not Req'd	0.00	0.00
+1.40D+1.60H	1	9.88	21.00	-2.17	2.17	18.95	1.00	10.48	Vu < PhiVc/2	Not Req'd	0.00	0.00
+1.40D+1.60H	1	10.16	21.00	-1.85	1.85	19.57	1.00	10.48	Vu < PhiVc/2	Not Req'd	0.00	0.00
+1.40D+1.60H	1	10.45	21.00	-1.53	1.53	20.09	1.00	10.48	Vu < PhiVc/2	Not Req'd	0.00	0.00
+1.40D+1.60H	1	10.73	21.00	-1.22	1.22	20.52	1.00	10.48	Vu < PhiVc/2	Not Req'd	0.00	0.00
+1.40D+1.60H	1	11.01	21.00	-0.91	0.91	20.86	1.00	10.48	Vu < PhiVc/2	Not Req'd	0.00	0.00
+1.40D+1.60H	1	11.29	21.00	-0.60	0.60	21.12	0.69	10.01	Vu < PhiVc/2	Not Req'd	0.00	0.00
+1.40D+1.60H	1	11.58	21.00	-0.30	0.30	21.29	0.34	9.49	Vu < PhiVc/2	Not Req'd	0.00	0.00
+1.20D+1.60L+0.50S+1.60H	1	11.86	21.00	0.01	0.01	18.32	0.01	9.00	Vu < PhiVc/2	Not Req'd	0.00	0.00
+1.40D+1.60H	1	12.14	21.00	0.30	0.30	21.38	0.34	9.48	Vu < PhiVc/2	Not Req'd	0.00	0.00
+1.40D+1.60H	1	12.42	21.00	0.60	0.60	21.29	0.68	10.00	Vu < PhiVc/2	Not Req'd	0.00	0.00
+1.40D+1.60H	1	12.71	21.00	0.91	0.91	21.12	1.00	10.48	Vu < PhiVc/2	Not Req'd	0.00	0.00
+1.40D+1.60H	1	12.99	21.00	1.22	1.22	20.86	1.00	10.48	Vu < PhiVc/2	Not Req'd	0.00	0.00
+1.40D+1.60H	1	13.27	21.00	1.53	1.53	20.52	1.00	10.48	Vu < PhiVc/2	Not Req'd	0.00	0.00
+1.40D+1.60H	1	13.55	21.00	1.85	1.85	20.09	1.00	10.48	Vu < PhiVc/2	Not Req'd	0.00	0.00
+1.40D+1.60H	1	13.84	21.00	2.17	2.17	19.57	1.00	10.48	Vu < PhiVc/2	Not Req'd	0.00	0.00
+1.40D+1.60H	1	14.12	21.00	2.51	2.51	18.95	1.00	10.48	Vu < PhiVc/2	Not Req'd	0.00	0.00
+1.40D+1.60H	1	14.40	21.00	2.85	2.85	18.25	1.00	10.48	Vu < PhiVc/2	Not Req'd	0.00	0.00
+1.40D+1.60H	1	14.68	21.00	3.20	3.20	17.44	1.00	10.48	Vu < PhiVc/2	Not Req'd	0.00	0.00
+1.40D+1.60H	1	14.96	21.00	3.57	3.57	16.54	1.00	10.48	Vu < PhiVc/2	Not Req'd	0.00	0.00
+1.40D+1.60H	1	15.25	21.00	3.95	3.95	15.53	1.00	10.48	Vu < PhiVc/2	Not Req'd	0.00	0.00
+1.40D+1.60H	1	15.53	21.00	4.34	4.34	14.42	1.00	10.48	Vu < PhiVc/2	Not Req'd	0.00	0.00
+1.40D+1.60H	1	15.81	21.00	4.74	4.74	13.19	1.00	10.48	Vu < PhiVc/2	Not Req'd	0.00	0.00
+1.40D+1.60H	1	16.09	21.00	5.16	5.16	11.85	1.00	10.48	Vu < PhiVc/2	Not Req'd	0.00	0.00
+1.40D+1.60H	1	16.38	21.00	5.59	5.59	10.40	1.00	10.48	PhiVc/2 < Vu <=	Not Req'd 1	0.00	0.00
+1.40D+1.60H	1	16.66	21.00	6.04	6.04	8.82	1.00	10.48	PhiVc/2 < Vu <=	Not Req'd 1	0.00	0.00
+1.40D+1.60H	1	16.94	21.00	6.51	6.51	7.11	1.00	10.48	PhiVc/2 < Vu <=	Not Req'd 1	0.00	0.00
+1.40D+1.60H	1	17.22	21.00	6.99	6.99	5.28	1.00	10.48	PhiVc/2 < Vu <=	Not Req'd 1	0.00	0.00
+1.40D+1.60H	1	17.51	21.00	7.49	7.49	3.30	1.00	10.48	PhiVc/2 < Vu <=	Not Req'd 1	0.00	0.00
+1.40D+1.60H	1	17.79	21.00	8.00	8.00	1.19	1.00	10.48	PhiVc/2 < Vu <=	Not Req'd 1	0.00	0.00
+1.40D+1.60H	1	18.07	21.00	8.54	8.54	1.07	1.00	10.48	PhiVc/2 < Vu <=	Not Req'd 1	0.00	0.00
+1.40D+1.60H	1	18.35	21.00	9.09	9.09	3.48	1.00	10.48	PhiVc/2 < Vu <=	Not Req'd 1	0.00	0.00
+1.40D+1.60H	1	18.64	21.00	9.66	9.66	6.05	1.00	10.48	PhiVc/2 < Vu <=	Not Req'd 1	0.00	0.00
+1.40D+1.60H	1	18.92	21.00	10.24	10.24	8.77	1.00	10.48	PhiVc/2 < Vu <=	Not Req'd 1	0.00	0.00
+1.40D+1.60H	1	19.20	21.00	10.84	10.84	11.66	1.00	10.48	Vu > PhiVc	0.3632	0.00	10.50
+1.40D+1.60H	1	19.48	21.00	11.46	11.46	14.72	1.00	10.48	Vu > PhiVc	0.9795	0.00	10.50
+1.40D+1.60H	1	19.76	21.00	12.09	12.09	17.96	1.00	10.48	Vu > PhiVc	1.610	0.00	10.50
+1.40D+1.60H	1	20.05	21.00	-9.67	9.67	20.32	1.00	10.48	PhiVc/2 < Vu <=	Not Req'd 1	0.00	0.00
+1.40D+1.60H	1	20.33	21.00	-9.01	9.01	17.59	1.00	10.48	PhiVc/2 < Vu <=	Not Req'd 1	0.00	0.00
+1.40D+1.60H	1	20.61	21.00	-8.34	8.34	15.04	1.00	10.48	PhiVc/2 < Vu <=	Not Req'd 1	0.00	0.00
+1.40D+1.60H	1	20.89	21.00	-7.66	7.66	12.69	1.00	10.48	PhiVc/2 < Vu <=	Not Req'd 1	0.00	0.00
+1.40D+1.60H	1	21.18	21.00	-6.97	6.97	10.53	1.00	10.48	PhiVc/2 < Vu <=	Not Req'd 1	0.00	0.00
+1.40D+1.60H	1	21.46	21.00	-6.27	6.27	8.56	1.00	10.48	PhiVc/2 < Vu <=	Not Req'd 1	0.00	0.00
+1.40D+1.60H	1	21.74	21.00	-5.57	5.57	6.78	1.00	10.48	PhiVc/2 < Vu <=	Not Req'd 1	0.00	0.00
+1.40D+1.60H	1	22.02	21.00	-4.85	4.85	5.21	1.00	10.48	Vu < PhiVc/2	Not Req'd	0.00	0.00
+1.40D+1.60H	1	22.31	21.00	-4.13	4.13	3.84	1.00	10.48	Vu < PhiVc/2	Not Req'd	0.00	0.00
+1.40D+1.60H	1	22.59	21.00	-3.39	3.39	2.68	1.00	10.48	Vu < PhiVc/2	Not Req'd	0.00	0.00
+1.40D+1.60H	1	22.87	21.00	-2.65	2.65	1.72	1.00	10.48	Vu < PhiVc/2	Not Req'd	0.00	0.00



Performance Engineers  
 1102 N. Franklin Blvd  
 Nampa, ID 83687

Project Title:  
 Engineer:  
 Project ID:  
 Project Descr:

## Beam on Elastic Foundation

File = U:\Desktop\Folders\2018-0\CALCUL-1107 Foundation.ec6 .  
 Software copyright ENERCALC, INC. 1983-2018, Build:10.18.11.30 .

Lic. # : KW-06007473

Licensee : SHAWN REEDER

Description : Garage door foundation loading

### Detailed Shear Information

Load Combination	Span Number	Distance (ft)	'd' (in)	Vu (k)		Mu (k-ft)	d*Vu/Mu	Phi*Vc (k)	Comment	Phi*Vs (k)	Spacing (in)	
				Actual	Design						Req'd	Suggest
+1.40D+1.60H	1	23.15	21.00	-1.90	1.90	0.97	1.00	10.48	Vu < PhiVc/2	Not Reqd	0.00	0.00
+1.40D+1.60H	1	23.44	21.00	-1.15	1.15	0.43	1.00	10.48	Vu < PhiVc/2	Not Reqd	0.00	0.00
+1.40D+1.60H	1	23.72	21.00	-0.39	0.39	0.11	1.00	10.48	Vu < PhiVc/2	Not Reqd	0.00	0.00